WILLOWGROVE

PROJECT DESCRIPTION

March 2026

The Willowgrove Project (formerly Shriners) consists of approximately 232 acres and is located adjacent to the northeastern boundary of the City of Davis. The Property was formerly owned by Shriners, and the project was initially referred to as Shriners for historical reference. While the project has been refined in response to initial feedback to increase density and enhance sustainability features, the Willowgrove project remains consistent with the initial project proposal for the Shriners property, and the change in name does not reflect a change in the project. That said, the project was named Willowgrove to symbolize the commitment of the project team to design and construct a project that blends with established Davis communities while offering a new place to recreate, socialize, and traverse beneath the shaded groves that will become a central design feature of the project.



Willowgrove is the first annexation project in Davis that has prepared small and large lot tentative subdivision maps prior to City and voter approval, which allows the City and public to evaluate and understand the details of the new community. The investment in preparing the tentative maps prior to City and voter approval will also expedite delivery of new homes.

Project Site

The site is generally rectangular, with dimensions roughly 1/2 mile across and 3/4 of a mile long. The site consists of APN 071-130-007-000. The property is located north of East Covell Boulevard and Mace Ranch. Southeast of the property is the Frances Harper Junior High School. West of the property is the Wildhorse community, their agricultural buffer and trail system, the Wildhorse golf course, and the proposed Palomino Place. Ongoing agricultural operations occur north and east of the site. The property is approximately one mile north of Interstate 80 and the Mace Boulevard exit.

Project Location & Setting



Source: Google Earth

Project Setting

The Yolo County General Plan and Zoning designations for the property are Agricultural (AG) and Agricultural Intensive (A-N). The topography is generally flat and sloping to the north, and the property is currently utilized for agriculture. Dirt roads bisect the site in several locations and also loop around the property. A tributary to Willow Creek, Channel A, bisects the northern portion of the property, continuing through the Wildhorse Golf Course to the west. In the northwest quadrant, an existing road crossing allows farming operations to continue from Channel A to the northern boundary. Existing trees on the property are located adjacent to East Covell Boulevard and along both sides of Channel A. Northeast of the property, the City recently secured a public trail easement on the Gill Orchard property, with plans to ultimately connect that trail to the Wildhorse greenbelt system. There is an existing grade separated crossing of East Covell Boulevard in the southwestern corner of the project, the site for which was previously secured and constructed by the City creating safe pedestrian access to the bikeway and trail systems on both sides of that street.

Project Objectives

1. Provide a meaningful number of critically needed housing units for the City, in a balanced and wide variety of densities, products, and price points.
2. Provide 20 percent of the total residential units for the construction of deed-restricted affordable housing for low, very low, and extremely low-income households.
3. Provide more attainable homeownership opportunities for the “missing middle” and young families, including 23 percent of the total residential units offering higher density condominiums/townhomes that are more affordable and attainable by design.
4. Prioritize the use of high and medium density housing for the missing middle and young families who are currently unable to find or afford housing in Davis.
5. Create the type of housing that will encourage young families to buy and live in Davis, increasing the number of children attending Davis Joint Unified School District (DJUSD) schools.
6. Encourage people living outside and commuting into Davis to live in Davis, thereby reducing vehicle miles traveled (VMT) and associated environmental impacts.
7. Respect existing agricultural uses by providing buffers that create a transitional space and encourage residents to appreciate the value of both uses coexisting together while establishing a thoughtfully designed urban City boundary.
8. Develop an inclusive community for all, including those with intellectual or developmental disabilities with independent housing, recreation, and employment opportunities designed to meet the unique needs of that cohort.
9. Provide a vibrant community park with active ballfields, inclusive play areas, and an indoor gymnasium, proximate to existing residents as well as new homeowners.
10. Provide a transit station and stops, allowing easy access to transit for neighborhood residents and visitors and reducing the use of individual automobiles.
11. Create outdoor educational opportunities for various age groups and abilities, which encourage exploration and complement existing programs within the City.
12. Expand the City’s existing bikeway and pedestrian trail system and provide important connections to new off-site bikeways and existing public trails.
13. Support existing retailers by avoiding the construction of brick-and-mortar retail and instead providing an eclectic neighborhood retail and entertainment area with opportunities to incorporate a Competitive Integrated Employment (CIE) program for persons living with intellectual or developmental disabilities.
14. Design an environmentally sensitive and sustainable community that features an urban forest throughout the connected trail system and emphasizes the use of rooftop solar electricity to reduce the community’s environmental footprint, reduce automobile and water use, and increase tree cover.
15. Create an economically feasible project able to construct the special amenities and features proposed for the neighborhood.

Proposed Zoning



Proposed General Plan Land Use Plan

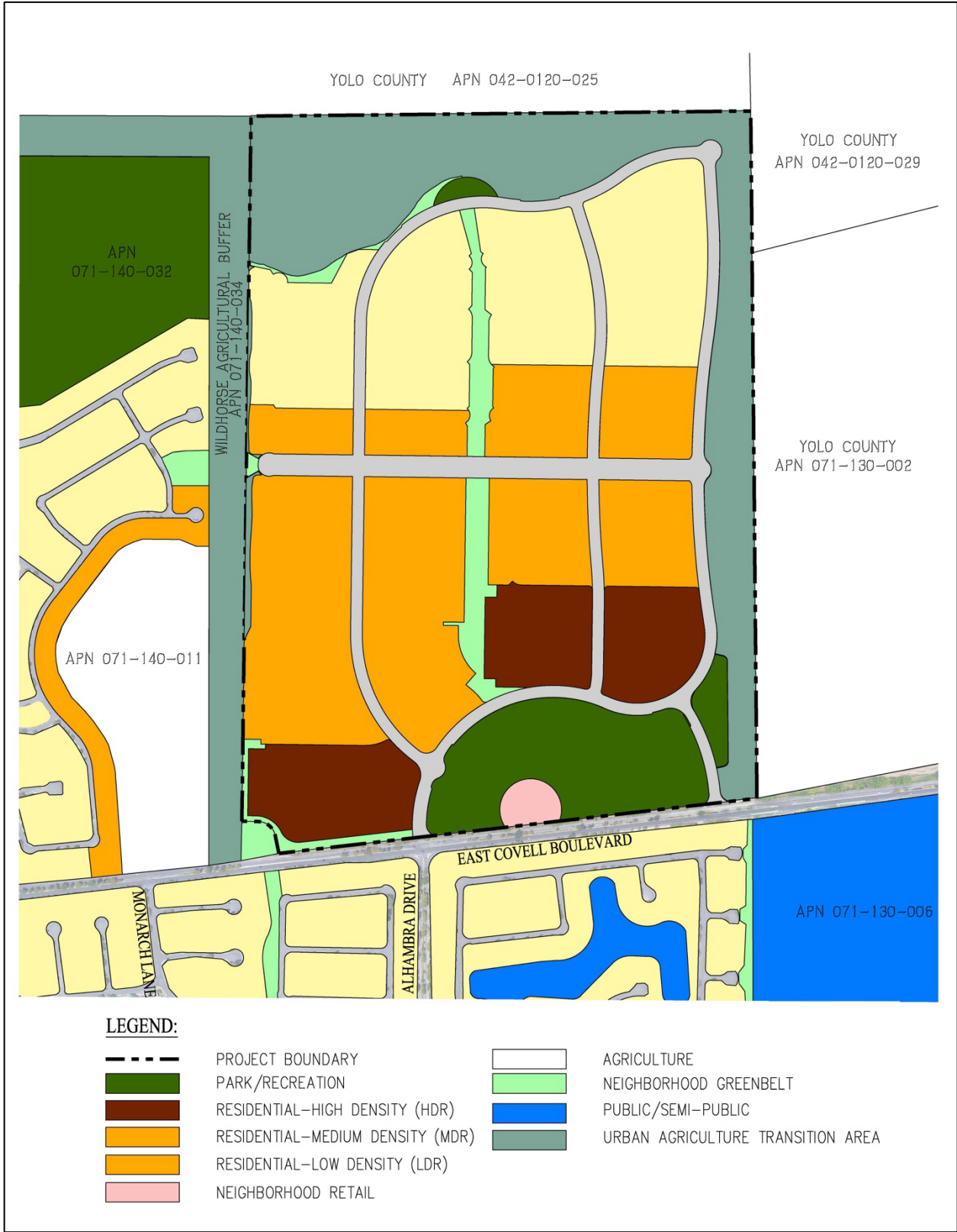

Conceptual Lotting Study



Project Components

The project proposes residential uses in a wide variety of products and densities, from high density attached product to traditional single family homes. Additionally, the project includes a community park, daycare site, mini-park, dog park, transit station and stop, small neighborhood retail, neighborhood greenbelts, and urban agricultural transition areas.

Land Use Summary		
Land Use Designation	Net Acres	Units
Residential Low Density	36.9	197
Residential Medium Density	51.8	515
Residential High Density	14.5	538
	Subtotal	103.2 1,250
Net Residential Density = 12.1 du/ac		
Urban Agricultural Transition Area (Community Garden, Trails)	44.3	
Park (Community Park, Mini-Park, Dog Park)	19.2	
Neighborhood Greenbelt	8.7	
Neighborhood Retail	1.5	
Additional Wildhorse Buffer	1.1	
	Subtotal	74.8
Street, Private Drive, Landscape Corridor	54.4	
	Total	232.4 1,250

Low Density Housing Example



Residential Land Uses

The project proposes Low, Medium, and High Density Residential land uses totaling 1,250 dwelling units, with an overall net residential density of 12.1 dwelling units per acre. The Residential Low Density (LDR) land use designation supports a range of single family detached homes. 197 dwelling units (16% of the total) are designated for LDR product types. These units will fall within the General Plan net density range of 2.88 – 5.75 dwelling units per acre (averaging approximately 5.3 units per acre), where a variety of larger detached single family housing types are possible. The project includes four LDR sites.

Medium Density Housing Example

The Residential Medium Density (MDR) land use designation accommodates single family detached as well as attached residential units. 515 dwelling units (41% of the total) are designated for MDR product types. These units will fall within the General Plan net density range of 5.76 - 13.44 dwelling units per acre (averaging approximately 10.0 units per acre), where housing types such as small single family, alley-loaded, greencourt, duplex, and townhomes are possible. The project includes eight MDR sites.



The Residential High Density (HDR) land use designation primarily accommodates attached residential units. 538 dwelling units (43% of the total) are designated for HDR product types. These units will fall within the General Plan (Medium High and High Density) net density range of 13.45 – 48.00 dwelling units per acre (averaging approximately 37.1 units per acre), where housing types such as apartments, both affordable and market rate, townhomes, condominiums, or stacked flats are possible. Affordable HDR units will be 3-story rental units, while market rate HDR units will be 2 or 3-story and may be for sale or rental units.

High Density Housing Example



Deed-Restricted Affordable Housing

Passionate about setting precedent for opportunity, affordable housing is a critical component of the HDR land use. Willowgrove is partnering with a leading affordable housing builder to provide 250 deed-restricted apartments for extremely low, very low, and low income individuals and families in a single phase. This constitutes 20% of the project's total units and provides 177% of the City Code requirement. Willowgrove is also partnering with Alta California Regional Center to set precedent in Davis as the first development designed with inclusivity as a core of the community with at least 10 affordable units serving individuals with intellectual and/or developmental disabilities (I/DD).

To advance delivery of these opportunities, Willowgrove will have the entire affordable HDR site construction ready before the first market rate occupancy permit is issued. The Willowgrove Affordable Housing Plan was revised throughout City review of the project to address two repeated concerns: (1) ensuring that the units are constructed; and (2) avoiding the use of limited City loans and grants to fund affordable housing. Through partnerships with a leading affordable housing developer and non-profits, Willowgrove will ensure construction of the 250 affordable units without the need for City loans or grants. The approximately 10.1-acre affordable housing site is located in the project's southwest corner next to a transit stop, the community park complex, the small neighborhood retail, pedestrian connections to the Wildhorse trail system, and the existing grade-separated crossing of East Covell Boulevard. The opportunity for a daycare facility is also included within the HDR parcel and could include an approximately 6,300 sf building and 2,700 sf outdoor play area.

Attainable By Design/ "Missing Middle" Housing

The project proposal also includes an additional 288 condominium or townhouse units, or 23% of the total unit count, that will provide homeownership opportunities lacking in Davis for the "missing middle" and young families. In 2024, the median home price in Davis of \$1,022,408 is at least 30% higher than any of its neighboring cities (Woodland, Winters, Dixon, West Sacramento, and Sacramento). The project's attached condominium/townhome units are designed to attract the "missing middle" age and income cohorts, hopefully with young families. While these units will not be subject to any ongoing affordability restrictions, the higher density and condominium/townhome product ensures that they remain attainable and affordable by design.

All of the Residential High Density (HDR) land uses have been thoughtfully located on the southern portion of the site, near the planned transit stops and the existing grade separated crossing of East Covell Boulevard, placing the highest density housing a short walk away from the community park, daycare facility, small neighborhood retail, and other neighborhood amenities.

Urban Agricultural Transition Areas and Neighborhood Greenbelts

The project is surrounded by urban agricultural transition areas, providing residents the opportunity to circumnavigate the entire area on a system of shared-use pathways. This loop consists of the existing Wildhorse agricultural buffer on the west, new passive nature area and agricultural buffer on the north, and new agricultural buffer on the east. The project's agricultural buffers have been designed to transition from an urban environment to an agricultural one. The meandering design of these buffers creates a more natural appearance, with tree groves and native plantings that provide a natural separation between uses. Water treatment, disguised in naturally occurring forms, will also provide visual interest and create additional variation along the edge. The project's agricultural buffers are not designed as the backside of the community, but instead invite residents to appreciate the value of both uses coexisting together.

Greenbelt Example



Green space not only surrounds the project, but also bisects it in two directions. This design creates four quadrants, each with convenient access to the trail system from anywhere in the neighborhood. The North Central Greenbelt links the community park on the south to the mini-park and passive nature area on the north. The 1/2 mile long Central Greenway supports both walkers and exercisers. Two gathering nodes are centrally located along the Greenbelt allowing residents to meet neighbors at a shaded bench, exercise together on outdoor fitness equipment, or talk in a quiet, comfortable space within view of nearby homes. Neighborhood design adjacent to the North Central Greenbelt incorporates street systems that loop or touch the greenbelt with open ended cul-de-sacs, providing multiple access points from within each individual neighborhood. The Central Green Street links the agricultural buffer on the east to Duchamp Park in Wildhorse on the west. This street is an important community element, providing the primary east-west pedestrian connection, and highlighting unique housing types within the community. Incorporation of I-streets or courtyard type product will remove the driveways from this street and create an entirely pedestrian experience, where the greenbelt passes along these showcase homes.

Neighborhood Greenbelts



Housing Example along Central Green Street



Existing Undercrossing of East Covell Boulevard



Connections from the project to off-site locations are also provided north to the Gill Property trail, west to the Wildhorse trails, and south via the existing undercrossing at East Covell Boulevard. The project is uniquely situated to take advantage of trails and bike connectivity to numerous destinations within the City, including schools, shopping, recreation, and jobs. By bike, the project is less than 10 minutes to Nugget Market, Target, and Grocery

Outlet and less than 20 minutes from UC Davis, Sutter Davis, and Davis Research Park. Over three miles of shared-use trails are proposed within the project, adding to the City's already robust bikeway and greenbelt systems.

Pedestrian Circulation

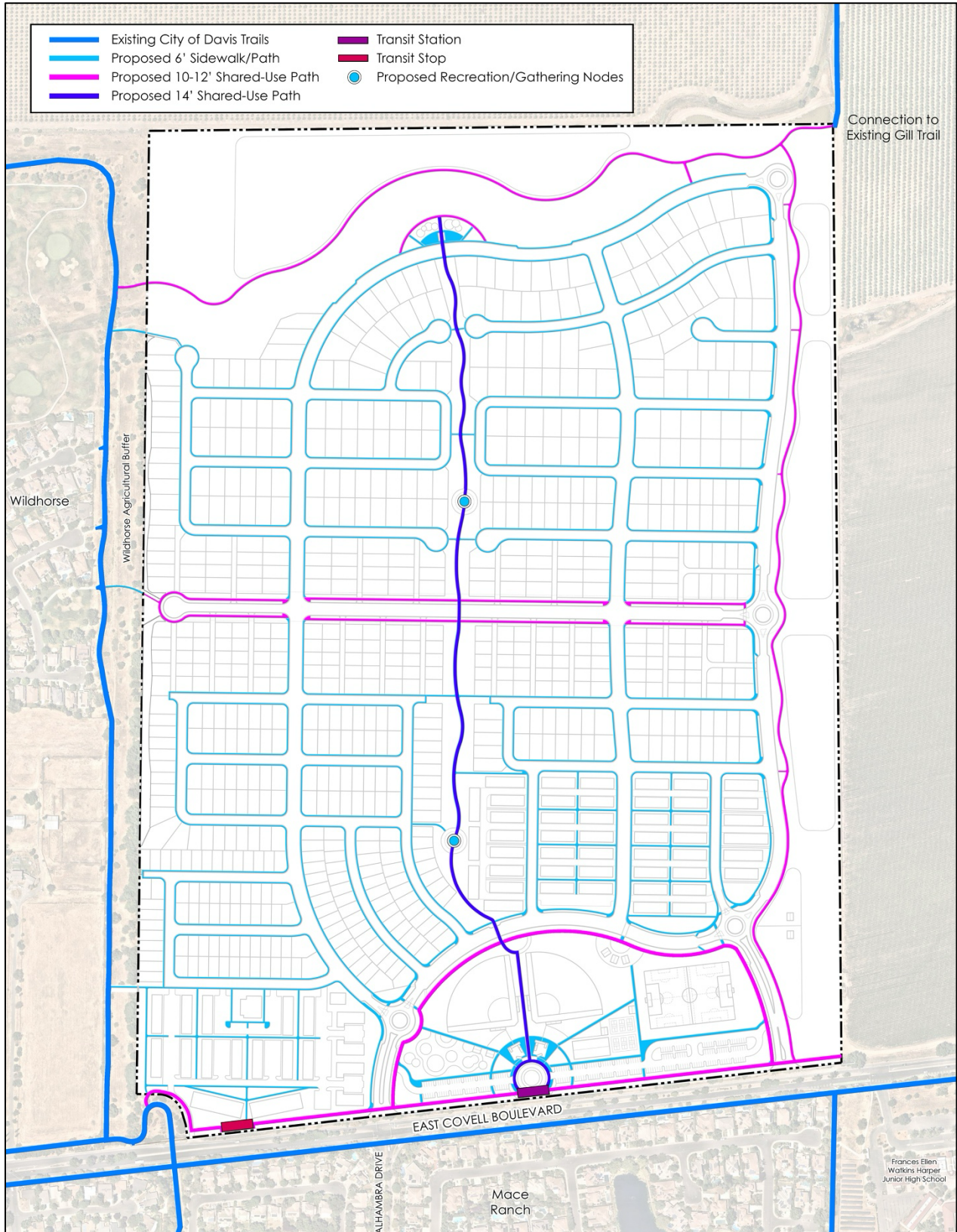

Safe Routes to Schools

Davis bike paths provide safe and convenient access from the existing East Covell Boulevard undercrossing on the southwest corner of the Willowgrove project to Fred Korematsu Elementary School, Harper Junior High School, and Davis Senior High School, as well as Birch Lane Elementary School and Marguerite Montgomery Elementary School. Crosswalks from the project site will also be provided at Alhambra Drive and the entrance to Harper Junior High School. With the existing undercrossing at southwest corner of project, Willowgrove connects to the City's safe routes to schools to provide convenient access to neighborhood schools without crossing a major road.

Elementary Schools and Frances Harper Junior High Connections to Safe Routes to School

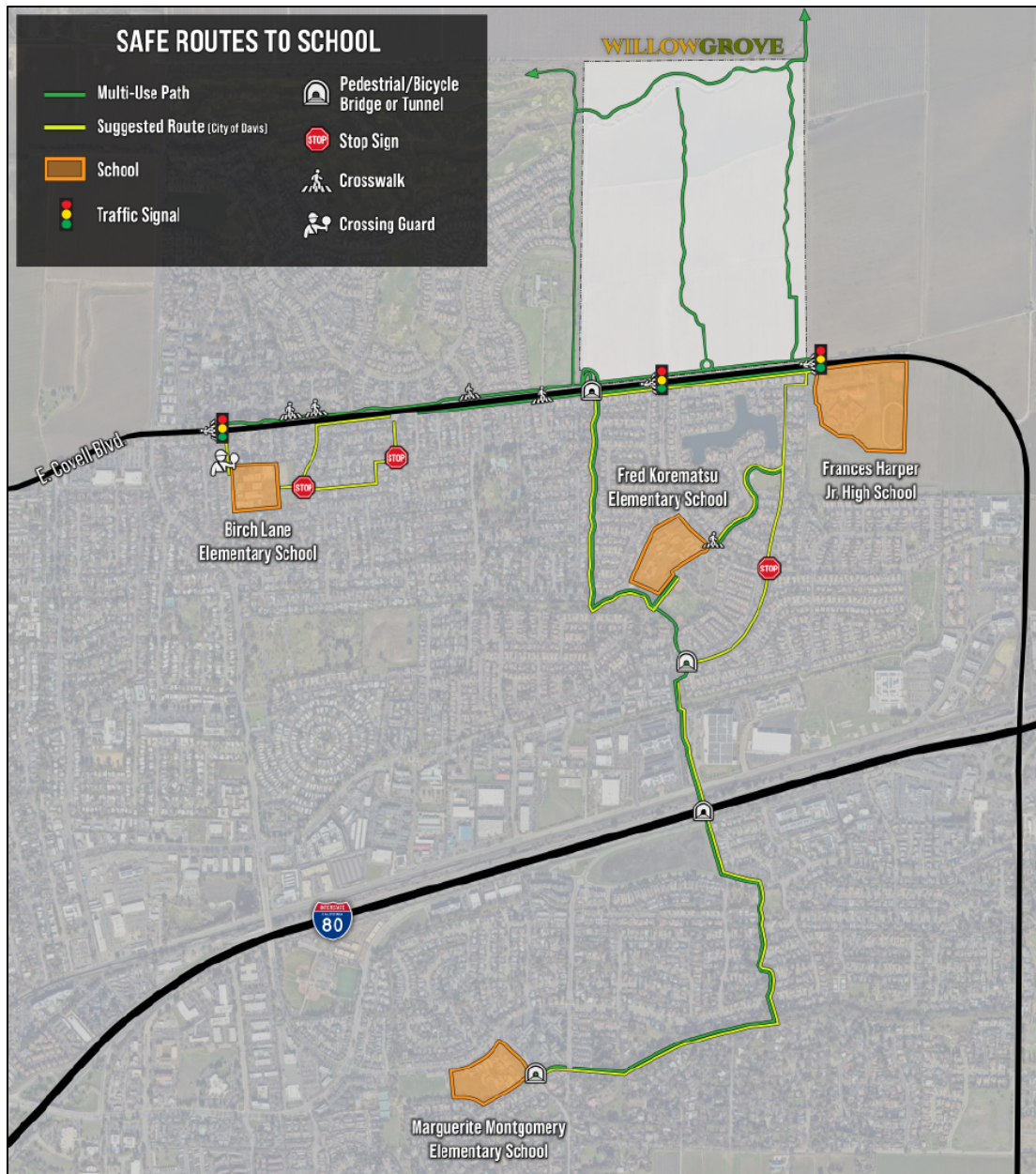

Davis Senior High School Connection to Safe Routes to School

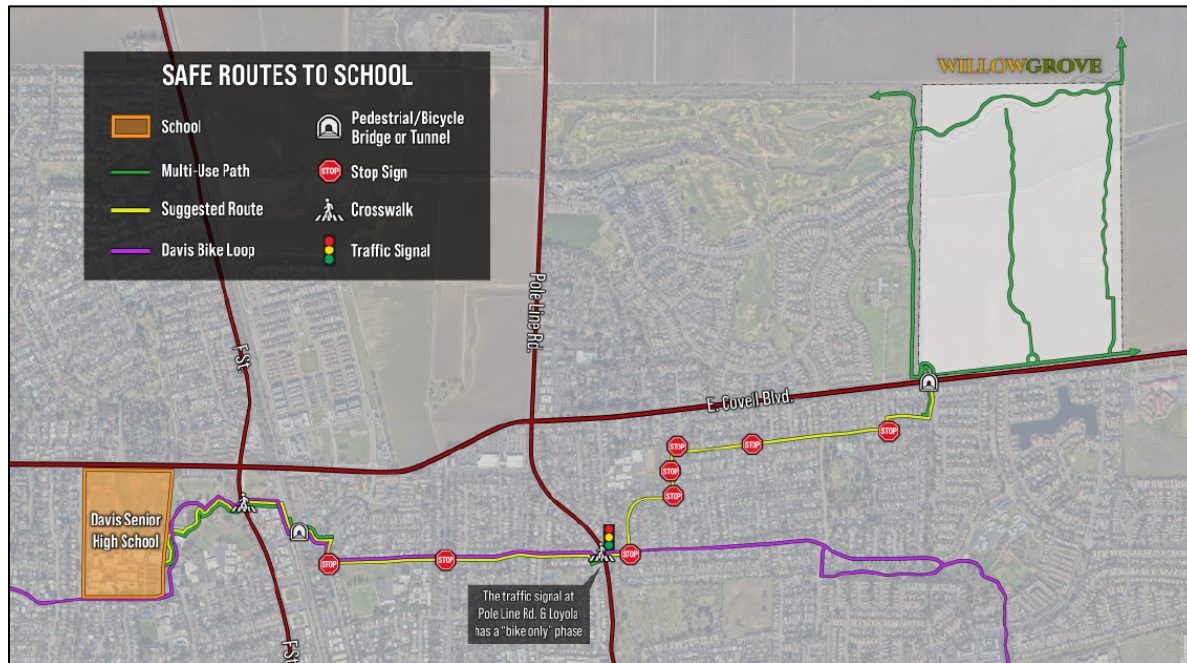

Open Space and Green Infrastructure

Over 72 acres (or 30% the overall project area) is devoted to open space and green infrastructure. This includes 19.2 acres of Parks, 8.7 acres of Neighborhood Greenbelt, and 44.3 acres of Urban Agricultural Transition Area along the northern and eastern project perimeter. Within these areas, residents will find a variety of active and passive outdoor opportunities that promote healthy living.

Greenbelts, located interior to the project, feature wide pathways that connect residents to all amenities. Parks provide a rich assortment of experiences to encourage activity. Residents seeking nature are a short stroll away from shared-use pathways in the Urban Agricultural Transition Area. Recreation/gathering nodes are also located along these pathways, allowing residents to gather under shade or exercise together on outdoor fitness equipment. All of these Green Infrastructure amenities have been specifically designed to promote health and wellness within the community. Connectivity extends beyond the project with four trail connections to the Wildhorse Agricultural Buffer, a trail to the Gill Orchard, and off-site pedestrian/bicycle connectivity to the Davis Bike Loop and other recreational spaces via the East Covell Boulevard undercrossing.

The 44.3 acres of Urban Agricultural Transition Area will also allow native habitat to return to the area, including the addition of a 50-foot buffer on the north and south of Channel A to allow the restoration of habitat in areas currently farmed. No development will occur north of Channel A.

To ensure long term financial sustainability for amenities and landscaping, a Services Community Facilities District (CFD) will be formed for the project. The CFD will provide annual maintenance funding. Multiple meetings with City of Davis staff and community focus groups informed the park system design concepts described herein.

Final Planned Development and Design Objectives

The Final Planned Development includes development standards for each product type, including design standards and landscape standards to ensure Willowgrove is thoughtfully designed with architectural variation within the community that still blends with the existing surrounding communities. Design objectives include:

- Drought tolerant and natural landscaping will be extensively employed along with the creation of a new urban forest with over 2,500 new trees.
- Trail, walkway, and street crossing design will emphasize safe and accessible means for pedestrians and bicyclists to navigate travel.
- Bicycle parking areas with racks will be easily identifiable at destination locations.
- Walkways will be appropriately sized to allow for concurrent pedestrian and bicycle usage, as well as maintenance vehicle access.
- Public art could be included for wayfinding, education, and as design elements to enhance the look-and-feel of amenities. Specific elements (i.e., poetry, murals, stamped concrete, themed play equipment) will be identified in final plans with public input.
- Consistent wayfinding signage will be created, making it easy to know where you are and how to get to a desired destination.



Green Infrastructure



Community Park Conceptual Design

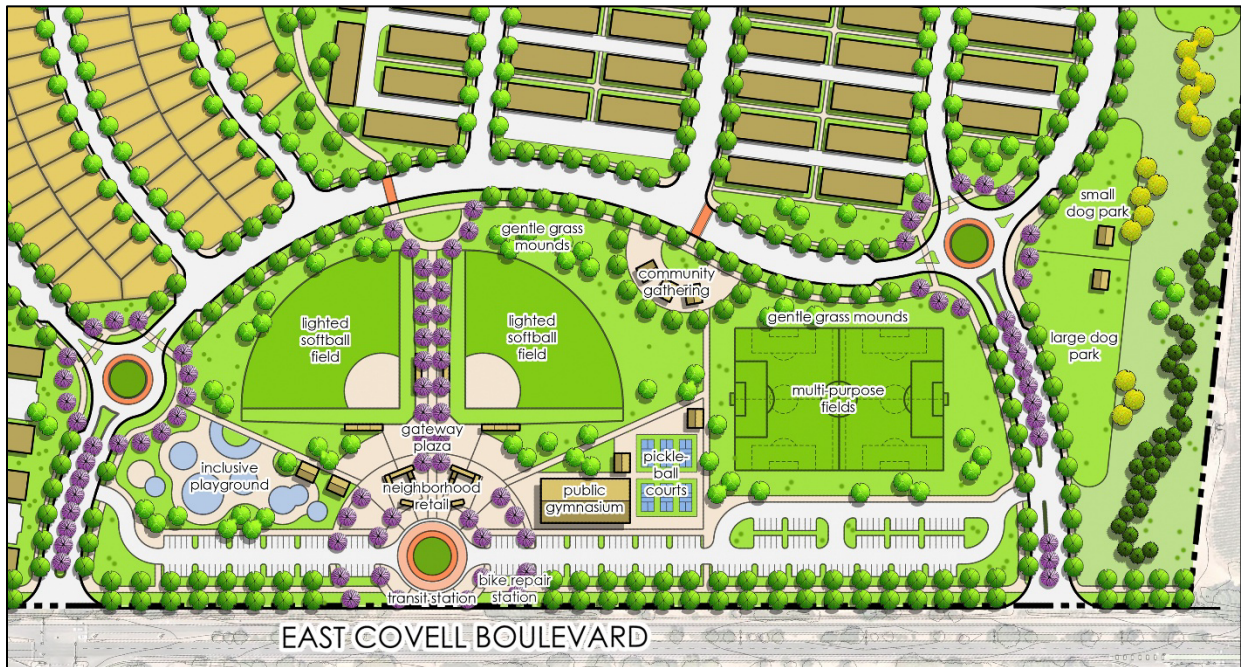

Community Park

Both entries into the neighborhood focus on the 18.6-acre Community Park and Dog Park. This park is prominently located adjacent to East Covell Boulevard, ensuring easy access for residents throughout the City without driving into the neighborhood. Residents wishing to bike or walk to the park have access from two crosswalks on the north side of the park, including one that aligns with the North Central Greenbelt.

The Community Park features numerous amenities emphasizing active use. The inclusive playground is one full acre with active options for users of all abilities and ages. The lighted softball fields, multi-purpose field, and pickleball courts allow extended activity into evening hours, as permitted by the City of Davis. Game play is anticipated on weeknights, with games or tournaments on weekends. After hours low-level security lighting will provide good visibility for safety personnel driving by the park.

The 9,500 square foot gym/classroom building supports indoor recreation opportunities like basketball, futsal, and enrichment programs. The building includes a gym with durable rubberized flooring, storage, a community room, and restrooms with exterior access for gym and park users. Gym and community room access comes from exterior doors into individual spaces. The building can operate without on-site staff for cost effectiveness.



Community Park Amenities

- Gateway Plaza: The large entry area north of the traffic circle is the gateway into the park from the parking area, where users are able meet up with friends and family. Shaded seating and trees in the Gateway Plaza invite users to relax before, during, and after activities. The Gateway Plaza has been designed large enough to accommodate other uses such as farmers markets, community events, and opportunities for public art.
- Transit Station: South of the traffic circle is a transit station located midway along the project frontage. This station is a critical connection point for non-vehicular travel and emphasizes the project’s commitment to alternative forms of transportation. The traffic calming effect of the roundabout allows transit users to safely access the park facilities from the station.
- Inclusive Playground: The all-abilities playground is three times the size of the Universal Playground at Central Park, with components for spinning, sliding, climbing, swinging, balancing, nature play, sand play, and respite. The playground includes a single point of entry and perimeter fence for secure use. Wide walkways promote accessibility. A shade structure with seating and multiple shade trees are planned.
- Two (2) lighted softball fields: 250' fenced field. Fields are set in the preferred north/south orientation. Each field includes low glare lighting, skinned infield, backstop, fencing around the field perimeter, player dugouts with seating, bleachers, and quick-connect bomber water behind pitching rubber. Fields support league and tournament play.

- One (1) Multipurpose Field: 330' x 225' field. Sized for high school soccer or lacrosse. Overlay fields provide two (2) U11-12 soccer fields of 225' x 150'. The field supports league and tournament play.
- Six (6) Lighted Pickleball Courts: 20' x 44' regulation size courts with 10' side lines/end lines in the preferred north/south orientation. Fully fenced. A shade structure allows participants to wait, watch, and relax when off the courts.
- Gym/Classroom Building: The building includes one (1) gymnasium with a 94' x 50' court, 10' sidelines, plus storage (480 sq. ft.); one (1) large community room; Multi-stall restrooms (the second of two restrooms in the park) are accessible to both gym and park users. By providing access to individual spaces from the exterior only, programming can be delivered by permitted users in one or more spaces while other spaces remain closed. The building is located close to both the Gateway Plaza and parking, allowing parents to relax while children are recreating inside the building. The community gym can also be used as a Resiliency Hub and evacuation center during emergencies.
- Dog Park: 1.5 acres total - 1.0 acre for large dogs and 0.5 acres for small dogs. The Dog Park includes a perimeter fence, concrete entry, shaded seating, and a human/dog water fountain. Located across street from the Community Park to prevent use conflicts. The Dog Park is easily accessed by connecting trails and from the Community Park parking area.
- Community Gathering Space: Three (3) shade structures with a small plaza are located on north side of park between the softball and multipurpose fields. GFCI plugs and after hours security lighting is included. Residents and community park users can enjoy a relaxed gathering space away from more active park uses.
- Parking: Parking is situated adjacent to East Covell Boulevard and buffered with lush landscaping which extends the entire length of the project frontage. Parking is purposefully situated near East Covell Boulevard so that residents from outside the neighborhood can easily access the park facilities without having to navigate through the internal portions of the neighborhood. This encourages residents within the neighborhood to walk to the park and reduces vehicle miles traveled from residents outside the neighborhood attending sporting events or visiting the park. The 215 spaces are sized to support maximum activity expected on weekends without being oversized for weekday activities. Access is from the project entries rather than directly from East Covell Boulevard. Tree wells are spaced every 50' to 70' to create shade and reduce asphalt heat.
- Walkways: 10' wide walkways radiate out from the Central Plaza and provide ample space for pedestrians and bicyclists, as well as access for maintenance vehicles.
- Gentle grass mounds: (5:1 slope) for spectator viewing are located outside the softball outfield fences and on the north side of the soccer field. These quiet viewing spaces compliment the bleacher seating located at the softball infield areas.

- Neighborhood Retail: A 1.5-acre parcel (separate from the Community Park) is located directly north of the transit station. This eclectic 5,000 sf retail space is envisioned for coffee shop and small eateries and cafes in an innovative, modular-style structures that will provide food and beverage service during sporting events, as well as the remainder of the week to neighborhood residents to provide walkable retail offerings.

Neighborhood Retail - Eclectic Architecture Examples



Mini Park Conceptual Design

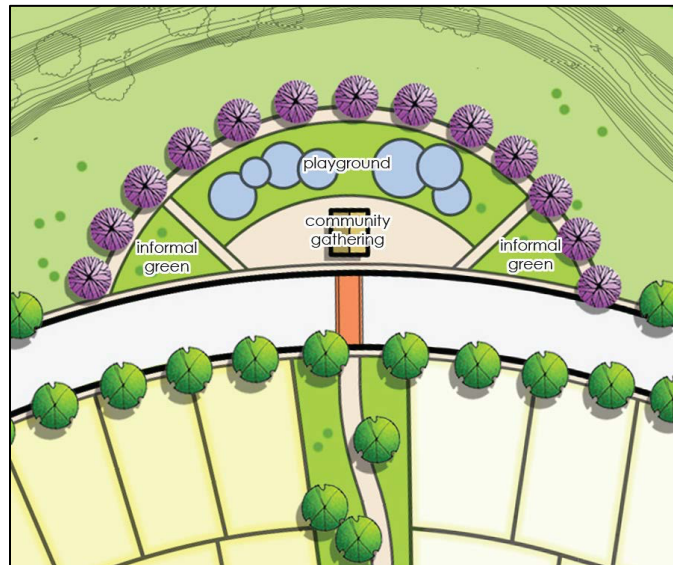

Mini Park

The 0.6 acre Mini Park is located at the north end of the project, easily accessed from North Central Greenbelt. This park emphasizes passive uses and serves as a gateway into the Urban Agricultural Transition Area. The Mini Park accommodates small groups, as compared to the Community Park where larger groups will gather. Visiting times at Mini-Parks tend to be shorter, so no restroom is proposed. The Mini Park is envisioned for residents who arrive primarily by walking or biking. No parking lot is proposed, but on street parking is available.

Mini Park Amenities

- **Community Gathering Space:** A central community gathering space will include a shade structure, tables, benches, and seating, with GFCI plugs and after hours security lighting. The space is the right size for birthday parties, book clubs, and family gatherings. The outdoor furniture doubles as an outdoor workspace and a place for relaxation.
- **Informal Green Space:** The small grass area supports frisbee, small games like corn hole and croquet, and sunbathing. The space is intentionally designed to preclude large-group practices or ballgames, as these are more appropriate at the Community Park.
- **Playground:** Designed for ages 2-5 emphasizing nature colors and equipment. This play space compliments the large inclusive playground at the Community Park. The playground is easily viewed from the shade structure and nearby benches under shade trees.
- **Education:** Interpretive signage in the Mini Park will inform users of local agricultural history and the benefits of nature in the Urban Agricultural Transition Area.

Public Art Program

The project proposes to include the use of public art to enhance its park, greenbelts, open space, and transit center areas. Incorporating locally sourced art brings additional pride and enjoyment to public spaces. The use of painted murals, tiles, poetry, and sculpture pieces by local artists and school children will be used to foster neighborhood identity and character and enhance way-finding throughout the project. Project proponents will work with city staff and the local art and school communities to identify locations and types of public art to be included in the neighborhood.

Vehicular Circulation

All of the major streets within the project incorporate gentle curves or enhanced medians that calm traffic and create a more pleasant driving experience. Neighborhood entries are no exception. Access comes from two intersections on East Covell Boulevard, one opposite the existing signal at Alhambra Drive, and the other one approximately 1/4 mile east. Both arc into the site embracing the community park, which acts as a focal point for the neighborhood and adjacent residential communities. Both entries include landscaped medians, separated walks and traffic circles at their intersections, ensuring that driving speeds into the neighborhood and around the park will be reduced. The entry section consists of a 15' landscaped median, 11' travel lanes and buffered 8' bike lanes. 6' sidewalks are separated by landscape corridors and no parking is allowed on this section.

From there, a modified local street meanders northward and connects to a traffic circle on the south side of Channel A. The curvilinear design adjacent to the eastern Urban Agricultural Transitional Area creates a more natural edge and emphasizes the green space and agricultural uses beyond. Traffic circles have been included at all major intersections, reducing speeds and pausing drivers at areas of visual interest. The street section consists of 10.5' and 10' travel lanes and buffered 7' minimum bike lanes. Parking is allowed on the residential side of this section and 6' sidewalks are separated by landscape corridors.

Modified local streets further disperse traffic into the neighborhood from the collector and entry streets. The primary east-west street, with an enhanced landscape setback, provides connectivity and opportunities for unique front-on architecture. The modified local section consists of 10.5' and 10' travel lanes, 8' and 7' bike lanes and 8' parking lanes. An attached 6' sidewalk is included with this section.

The internal street system is made up of local streets and private drives. Internal neighborhood street design will primarily be oriented east-west, creating home orientations that are more energy efficient. Local streets and private drives both consist of 13' and 10' travel lanes. Parking is allowed on both sides of local streets, but not within private drives. Local streets also include attached 6' sidewalks and private drives include 5' sidewalks.

Street Sections – Vicinity Map



Street Sections A, B and C – East Covell Boulevard and Entries

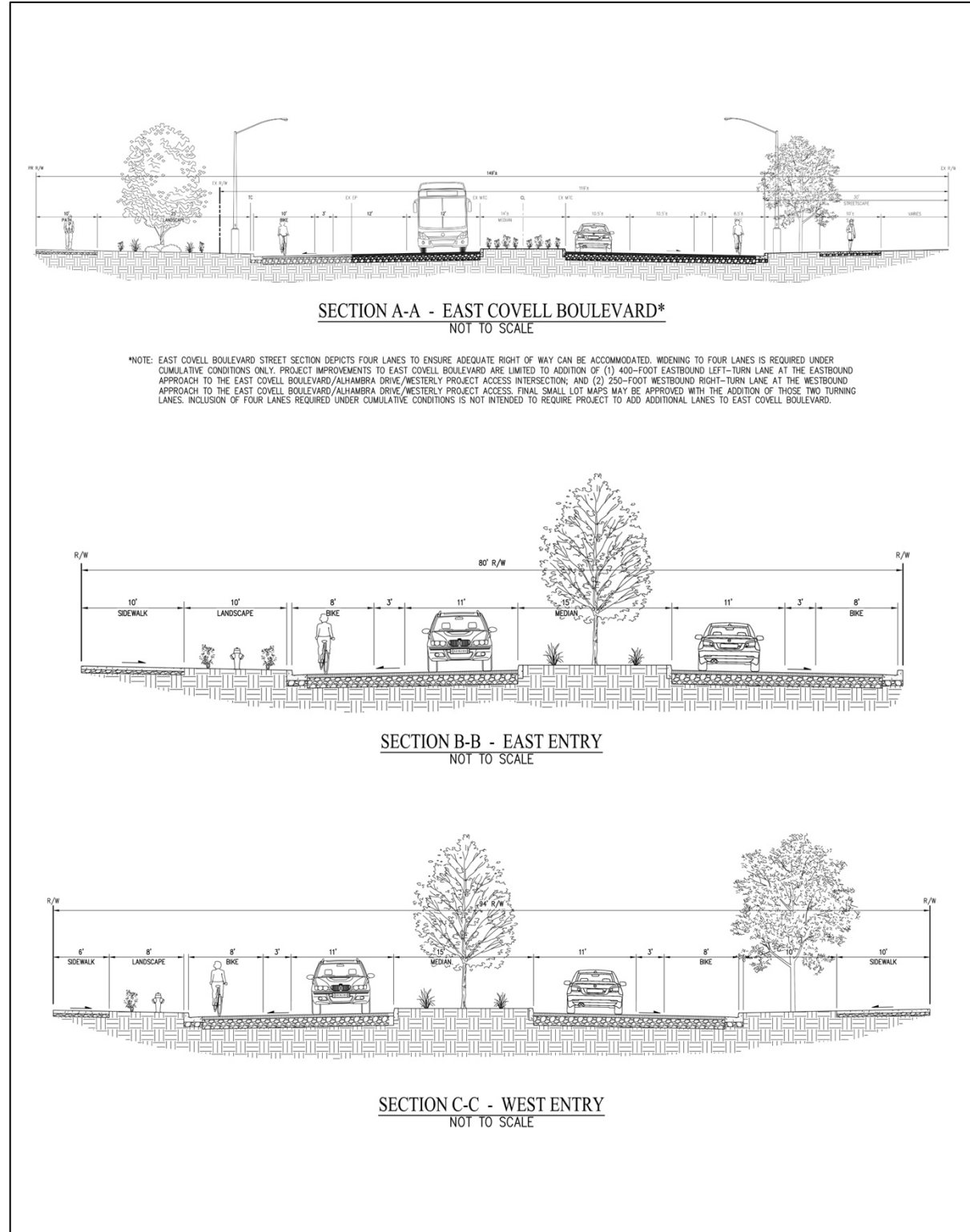

Street Sections D and E – Locals

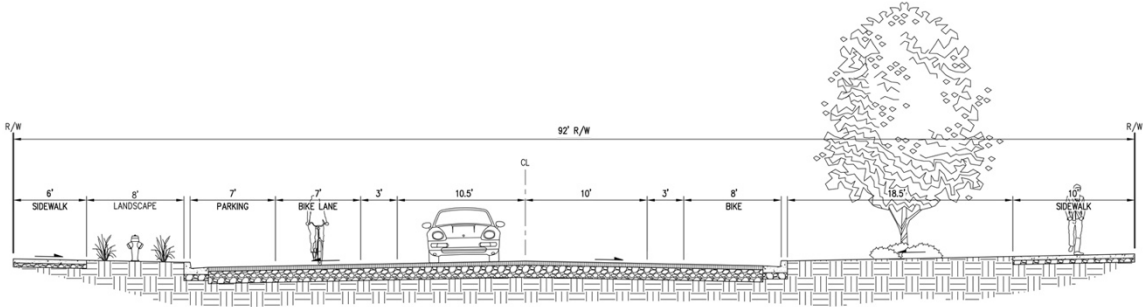

SECTION D-D - MODIFIED LOCAL
NOT TO SCALE

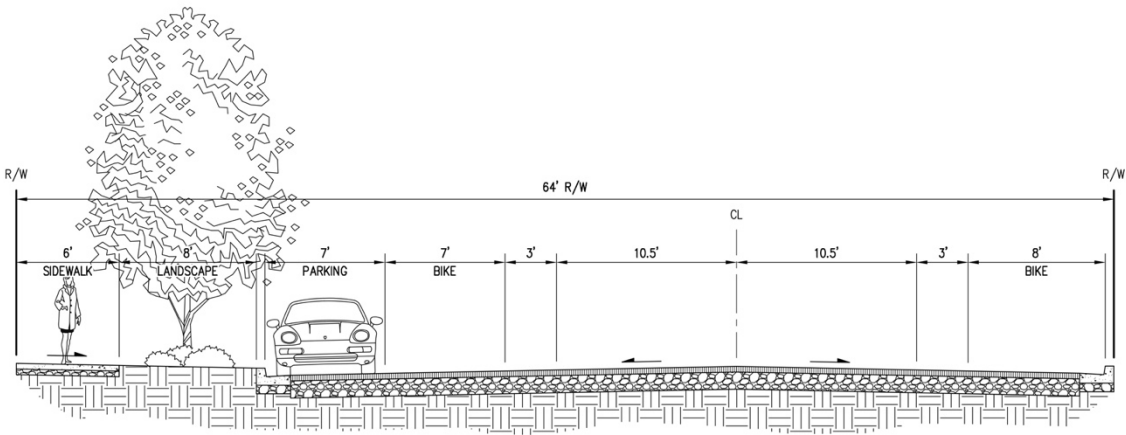

SECTION E-E - MODIFIED LOCAL
NOT TO SCALE

Street Sections F, G, H and I – Locals

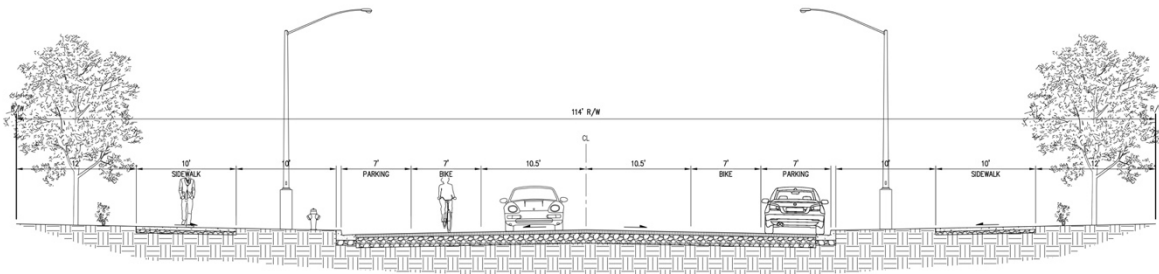

SECTION F-F - MODIFIED LOCAL
NOT TO SCALE

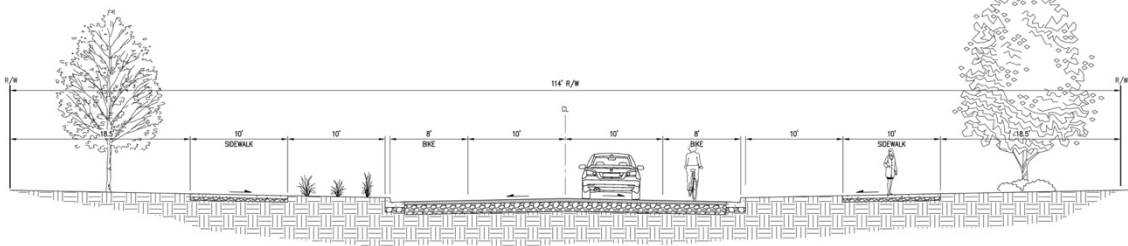

SECTION G-G - LOCAL
NOT TO SCALE

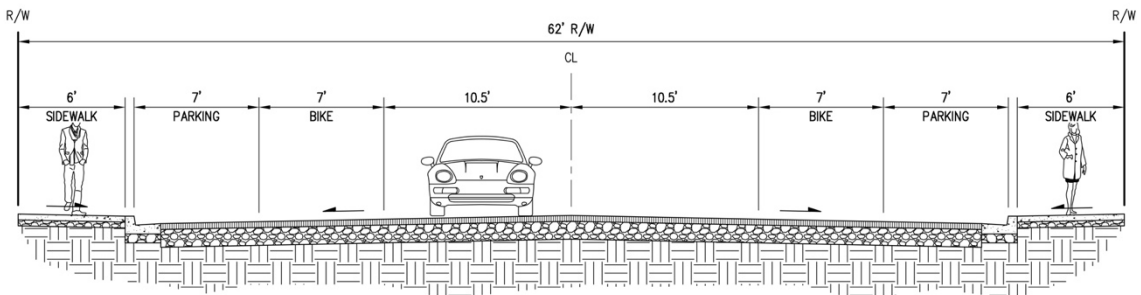

SECTION H-H - MODIFIED LOCAL
NOT TO SCALE

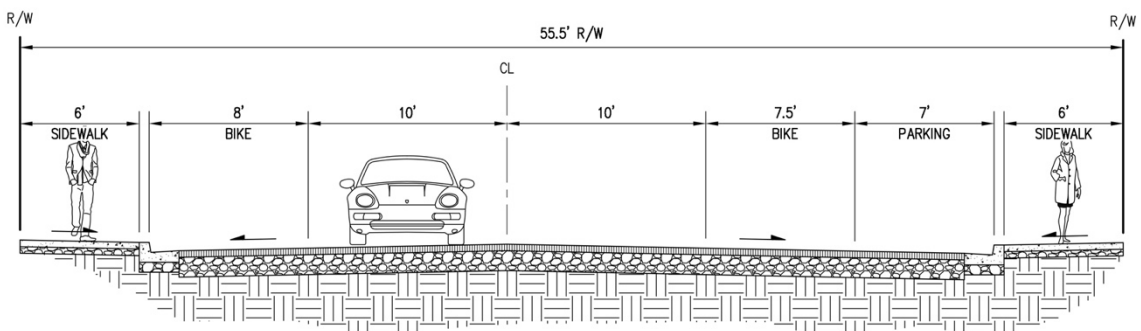

SECTION I-I - MODIFIED LOCAL
NOT TO SCALE

Street Sections J, K, L and M – Locals and Private Drives

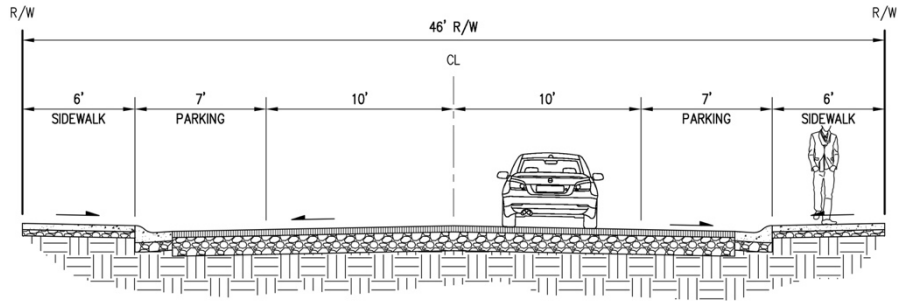

SECTION J-J - LOCAL
NOT TO SCALE

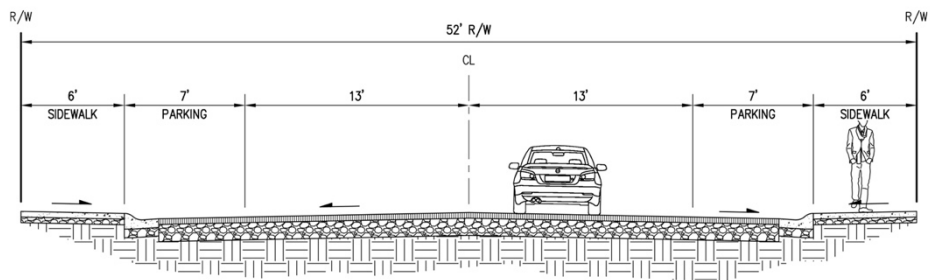

SECTION K-K - LOCAL
NOT TO SCALE

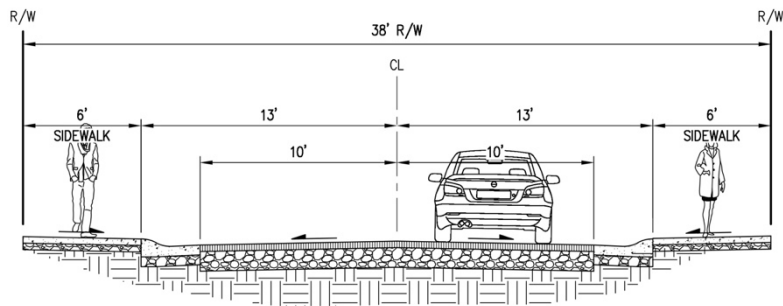

SECTION L-L - ALLEY
NOT TO SCALE

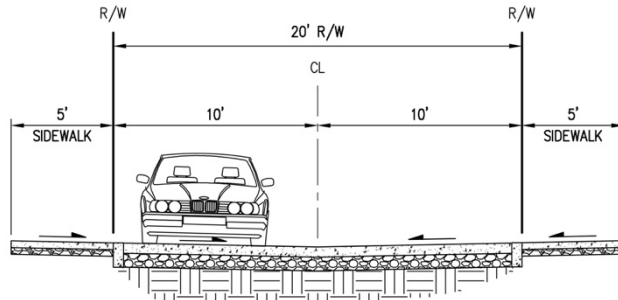

SECTION M-M - PRIVATE DRIVE
NOT TO SCALE

Vehicular Circulation

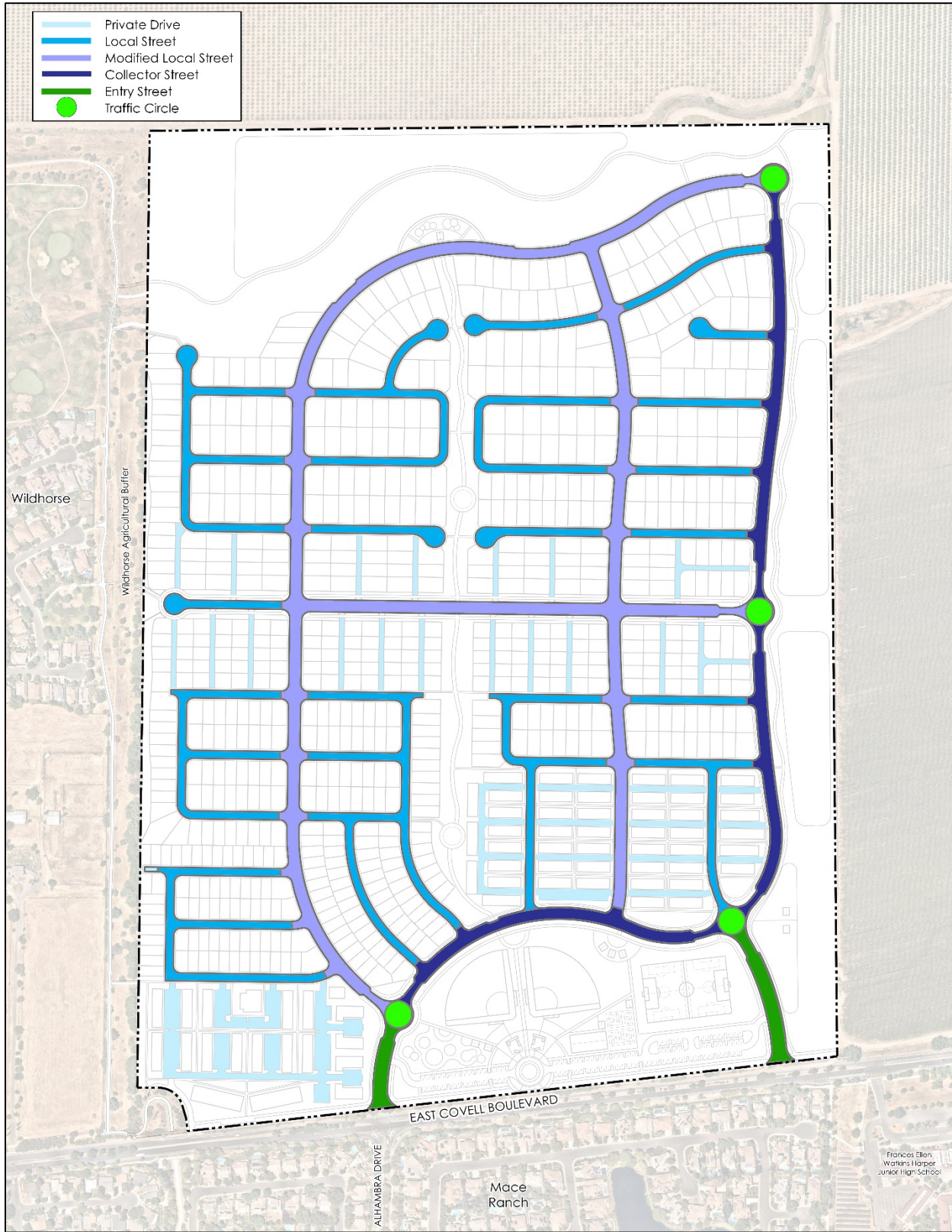

Traffic Calming Plan

A number of traffic calming measures have been incorporated into the vehicular circulation system design in order to encourage lower speeds and ensure safe pedestrian and bicycle travel within the community. These include roundabouts, speed humps, raised crosswalks, raised intersections, and corner extensions or bulbouts.

Roundabouts

A roundabout is an intersection design that contrasts with designs that require traffic signal control or stop control. A roundabout is often used as a replacement for a signalized intersection. A roundabout is sized to accommodate all large vehicles circulating the center island and the center island is non-traversable. A roundabout provides a horizontal deflection with an island at the entry point and requires every vehicle to follow a circuitous path no matter which departure leg of the intersection is the destination. As a result, traffic speeds are moderated while emissions from idling are reduced. The roundabout is included as a traffic calming measure because it can be used to change the operating character of a roadway as it transitions from a higher-speed operation to a lower-speed operation within a higher-density community with more pedestrian presence.

Speed Hump

A speed hump is an elongated mound in the roadway pavement surface extending across the travel way at a right angle to the traffic flow. A speed hump is typically 3 inches in height (with applications as high as 4 inches) and 12 feet in length along the vehicle travel path axis. At typical travel speeds along a residential street, a speed hump produces sufficient discomfort to a motorist driving above the speed hump design speed to discourage speeding. It encourages the motorist to travel at a slow speed both upstream and downstream of as well as over the speed hump.

Raised Crosswalk

A raised crosswalk is marked and signed as a pedestrian crossing. The 10-foot flat top on a typical speed table conforms to a desired crosswalk width. There are two distinct raised crosswalk designs. Both use a modified version of the common 22-foot speed table:

- The most common type is constructed flush against the roadside curb.
- The other type is constructed on an open section (requiring a curb ramp on the raised crosswalk) or separate from the curb (requiring a curb ramp on both the curb and the raised crosswalk).

A raised crosswalk improves pedestrian safety by causing motorist speed to decrease at the crossing. A raised crosswalk is typically between 3 and 6 inches above street level. It is common for a raised crosswalk to be level with the street curb. This height increases the visibility of a pedestrian in a crosswalk to a

motorist. It also improves the line of sight for a pedestrian toward an oncoming vehicle. A raised crosswalk can be placed midblock or at an intersection.

Raised Intersection

A raised intersection is a flat, raised area covering an entire intersection with ramps on all approaches. It is essentially a speed table that covers an entire intersection, including the crosswalks. The purpose of a raised intersection is to slow vehicle traffic through the intersection and to improve safety for pedestrians. It has the advantage of calming two streets at once. A raised intersection typically rises to sidewalk level. A typical installation is at a signal-controlled or all-way stop-controlled intersection with a large volume of street-crossing pedestrians. A raised intersection reinforces the need for a motorist to drive cautiously and be wary of crossing pedestrians.

Corner Extension/Bulbout

A curb extension is a horizontal extension of the sidewalk into the street resulting in a narrower roadway section. This device may be used at either corner or midblock. A curb extension at an intersection is called a corner extension or bulbout. A curb extension located midblock is called a choker. When combined with on-street parking, a corner extension can create a protected parking bay. The effect of a corner extension on vehicle speeds is limited because of the absence of either a pronounced vertical or horizontal deflection. Its primary purpose is to "pedestrianize" an intersection. A corner extension (with a reduced corner radius) slows automobile turning speeds, shortens pedestrian crossing distance, and increases pedestrian visibility. A corner extension can be combined with a vertical speed control device (e.g., a raised crosswalk) to achieve a greater reduction in vehicle speed.

Corner Extension/ Bulbout Detail

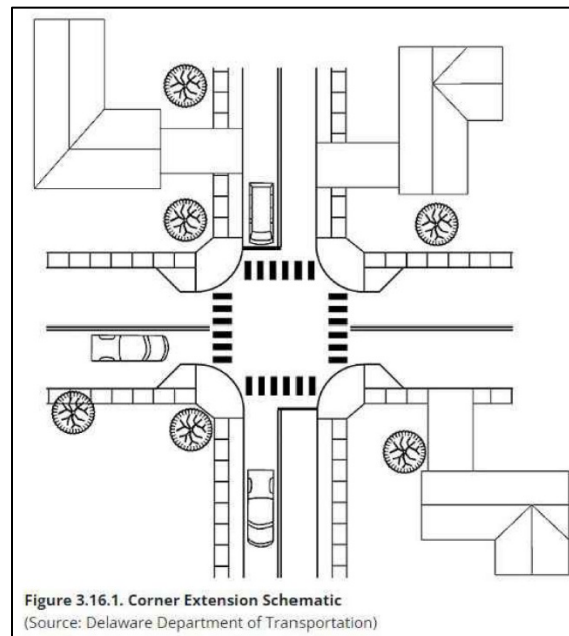

Proposed Traffic Calming

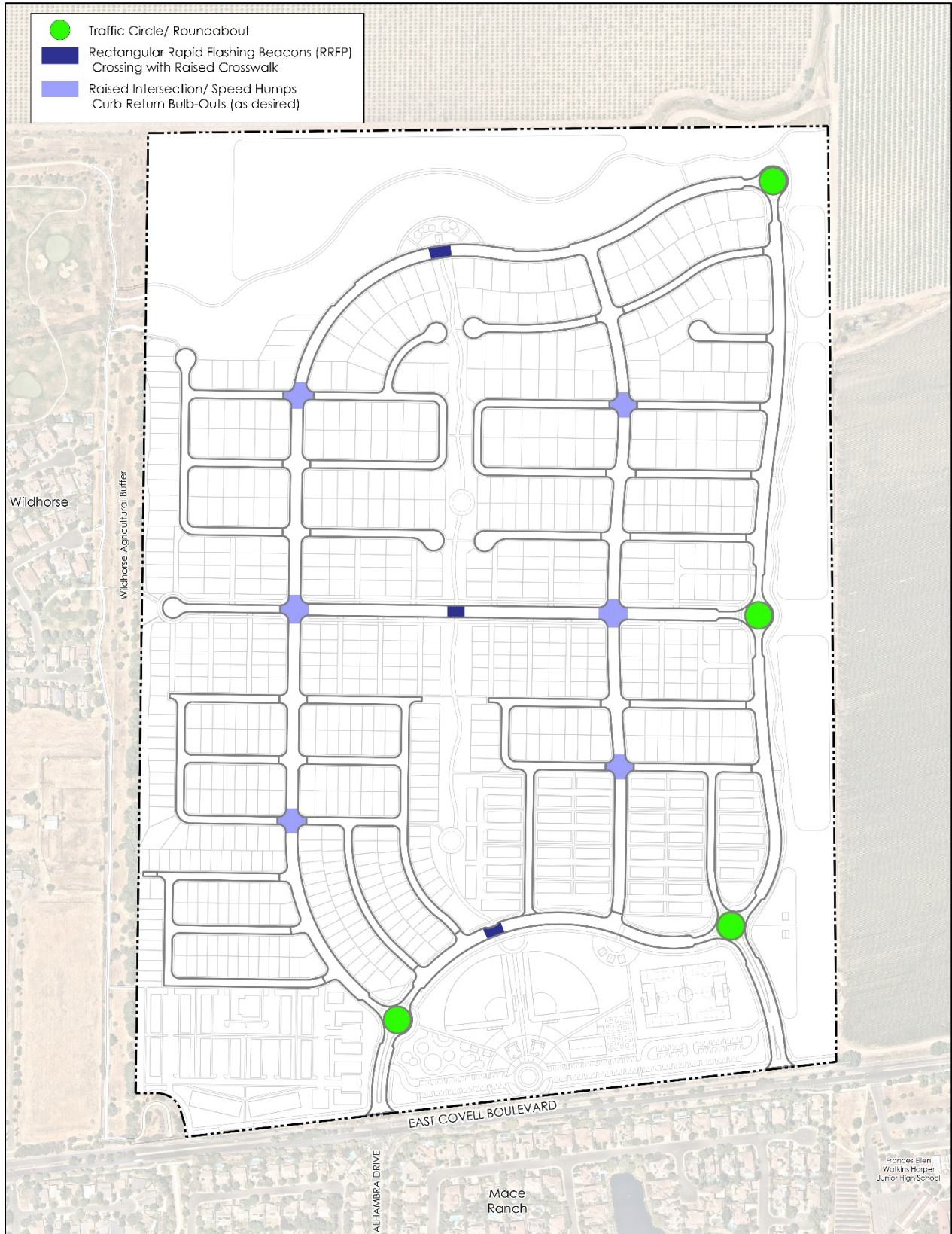

Sustainability Plan

With thoughtful design and green building practices expected in Davis, Willowgrove is committed to sustainability and advancing the City's 2020-2040 Climate Action and Adaptation Plan ("CAAP"). Consistent with the CAAP Climate Adaptation Goal to create a cooler city with more urban forest and green space, the project has integrated green space and an urban forest with 2,500 new trees to increase natural shade, reduce urban heat island impacts, and maximize carbon sequestration. The enhanced landscaping throughout the project will feature a native plant pallet that maximizes carbon sequestration while minimizing water consumption. With a commitment to renewable energy, the project will emphasize rooftop solar photovoltaic systems and increase renewable energy production beyond the minimums in Davis Code. The project will be all-electric without natural gas to reduce emissions from natural gas. The extensive trail network also connects to existing trails at numerous locations to promote bicycle and pedestrian use and reduce emissions from vehicles.

Project History

A Pre-Application for the property was submitted to the City in October 2021. In February 2022, City Staff provided comments on the proposal and the Conceptual Land Use Plan. The applicant and project team held a series of follow-up meetings with City Staff to discuss and clarify items from the initial round of comments. The project team prioritized tasks and made significant revisions to the project based on those meetings. In October 2022, the project team initiated a series of focus group meetings with members of the Davis community. These meetings were most valuable in determining the needs, values, and concerns of the community. The Willowgrove project proposal and land use design is a direct result of these important interactions. A formal application was submitted to the City in December 2022.

Entitlements

The proposed project requires the following entitlements and approvals:

- Certification of the EIR
- Adoption of a Mitigation Monitoring Plan (MMP)
- Extension of the City's Sphere of Influence (SOI)
- Annexation
- General Plan Amendment
- Pre-zoning
- Final Planned Development
- Development Agreement
- Large Lot Tentative Map
- Small Lot Tentative Map
- Affordable Housing Plan
- Development Agreement

Outreach Plan

Since 2021, the Willowgrove Development team has conducted a robust outreach and information-gathering program. The team regularly meets with City of Davis staff about community needs and project. Meetings with key stakeholders like the Davis Joint Unified School District, Legacy and AYSO Soccer, Davis Youth Softball Association (DYSA), Davis Little League, Purple Tree Café, and Davis Firefighters Local 3494, Alta Regional, Habitat for Humanity, and more have also been conducted.

The project team has held several focus groups of Davis citizens in key neighborhoods proximate to the project. The goal of these focus groups has been to determine community needs, seek design feedback, and hear concerns and pain points from people who live in Davis or would like to live in Davis. The team has targeted the “Missing Middle” (families with school-aged children) with these focus groups. Focus groups conducted thus far have included a general focus group open to anyone living inside of Davis or who would like to live inside of Davis, a Wildhorse focus group, a Cannery focus Group, a Mace Ranch and Lake Alhambra focus group, and a UC Davis student focus group. These focus groups have been incredibly informative and productive.

In addition to this personal outreach, the project team has also designed a robust website where interested parties can explore design plans and community concepts for the project. Interested parties can and have opted in for additional information as well. These parties are regularly updated on all project milestones and meetings.

The outreach program is a key component of what will make this project unique for Davis. For example, working with Alta Regional and providing housing for the ID/D community was a direct result of this kind of outreach and the Community Park was designed to meet existing City gaps in sports facilities for girls. Additionally, the inclusion of a public gymnasium and coffee shop/cafe were also a direct result of these outreach efforts. The eastern project edge was also redesigned as part of collaboration with Wildhorse residents and the project team’s commitment to become good neighbors. It has been and remains a project priority to hear and accommodate as many voices into this process as possible.

Summary

The Willowgrove project prioritizes housing for those who need it most, by contributing a responsible and balanced mix of housing for Davis, which includes deed-restricted affordable housing, attainable by design housing, and housing for the missing middle. In addition, the project proposes a robust package of amenities, including a community park, transit station, public gymnasium, eclectic neighborhood retail, outdoor education area, over 70 acres of greenspace, and three miles of new shared-use pathways. With the investment of tentative maps prior to City and voter approval, the details of the project have been designed and analyzed now to ensure that the City and public are informed of all aspects of the project before approval and that new homes can be promptly constructed after voter approval. Willowgrove doesn’t just meet City standards for new development, it exceeds them. The time for a development proposal of this quality in Davis is now.