

**NOTES:**

1. SITE AERIAL IMAGERY TAKEN IN JUNE 2021 AND WAS ACQUIRED MAY 13, 2020 FROM GOOGLE EARTH PRO. COPYRIGHT GOOGLE, 2015.
2. CONCEPTS SHOWN ON THIS EXHIBIT ARE PRELIMINARY IN NATURE AND ARE SUBJECT TO CHANGE BASED ON FINAL DESIGN.

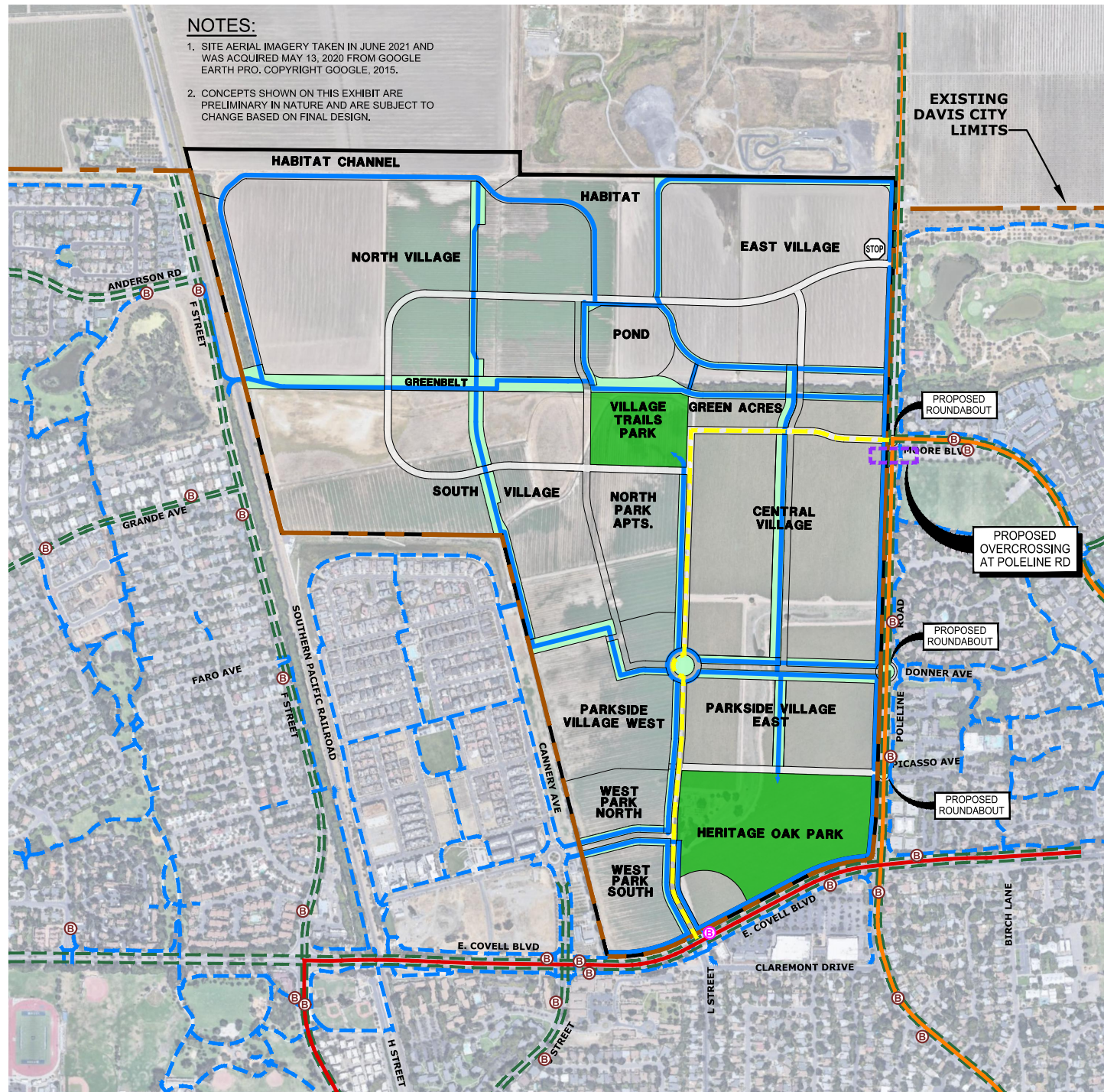

**LEGEND**

- EXISTING OFF STREET (CLASS I) BIKE/PEDESTRIAN PATH
- EXISTING ON STREET (CLASS II) BIKE LANES
- PROPOSED BIKE/PEDESTRIAN PATH (CLASS I)
- EXISTING P/Q BUS LINE
- EXISTING L BUS LINE
- PROPOSED BIKE PATH CROSSING
- PROPERTY BOUNDARY
- EXISTING CITY OF DAVIS LIMITS
- PROPOSED SCHOOL BUS ROUTE PICKUP
- Ⓟ EXISTING BUS STOP
- Ⓟ PROPOSED BUS STOP
- Ⓟ PROPOSED ROUNDABOUT

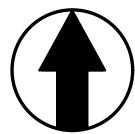

0 500 1,000  
SCALE: 1" = 1,000'

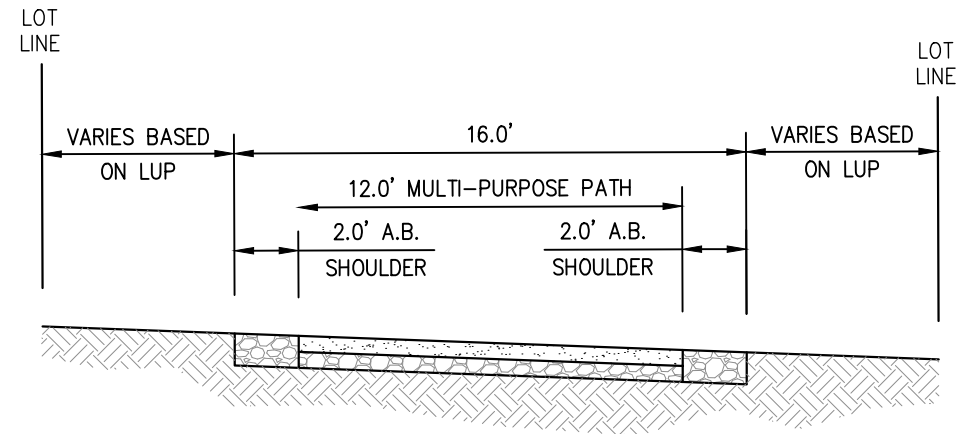

NTS

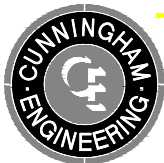

**VILLAGE FARMS DAVIS  
MOBILITY, BICYCLE AND TRAIL  
CIRCULATION EXHIBIT**