



CITY OF DAVIS

# Sewer System Management Plan

MARCH 2017



WEST YOST ASSOCIATES

# Sewer System Management Plan

Prepared for

## City of Davis

WDID 5SSO10921

Project #011-21-16-50

SSMP Adoption Date: \_\_\_\_\_, 2017

Original SSMP Adoption Date: 8-21-2012

Council Resolution Number: 12-127



Courtney Hall, Associate Engineer

March 30, 2017

Date

QA/QC Review: Jeffrey Pelz, Vice President

March 30, 2017

Date



#### Carlsbad

2173 Salk Avenue, Suite 250  
Carlsbad, CA 92008  
(760) 795-0365

#### Davis

**2020 Research Park Drive, Suite 100**  
**Davis, CA 95618**  
**(530) 756-5905**

#### Eugene

1650 W 11th Ave. Suite 1-A  
Eugene, OR 97402  
(541) 431-1280

#### Irvine

6 Venture, Suite 290  
Irvine, CA 92618  
(949) 517-9060

#### Pleasanton

6800 Koll Center Parkway, Suite 150  
Pleasanton, CA 94566  
(925) 426-2580

#### Portland

4949 Meadows Road, Suite 125  
Lake Oswego, OR 97035  
(503) 451-4500

#### Sacramento

2725 Riverside Boulevard, Suite 5  
Sacramento, CA 95818  
(916) 504-4915

#### Santa Rosa

2235 Mercury Way, Suite 105  
Santa Rosa, CA 95407  
(707) 543-8506

#### Sunnyvale

1250 Oakmead Parkway, Suite 210  
Sunnyvale, CA 94085  
(408) 451-8453

#### Turlock

200 North Broadway, Suite C  
Turlock, CA 95380  
(209) 226-6020

#### Walnut Creek

1777 Botelho Drive, Suite 240  
Walnut Creek, CA 94596  
(925) 949-5800

# Table of Contents

---

## Introduction

|  |     |
|--|-----|
| I.1 Introduction .....                             | I-1 |
| I.2 Definitions, Acronyms, and Abbreviations ..... | I-1 |
| I.3 Sanitary Sewer System Facilities .....         | I-6 |
| I.4 References .....                               | I-9 |

## Chapter 1. Element I: Goals

|                      |     |
|----------------------|-----|
| 1.1 SSMP Goals ..... | 1-1 |
|----------------------|-----|

## Chapter 2 Element II: Organization

|  |     |
|--|-----|
| 2.1 Organizational Structure .....                               | 2-1 |
| 2.2 Authorized Representatives .....                             | 2-2 |
| 2.3 Responsibility for SSMP Implementation and Maintenance ..... | 2-4 |
| 2.4 SSO Reporting Chain of Communication .....                   | 2-5 |

## Chapter 3 Element III: Legal Authority

|  |     |
|--|-----|
| 3.1 Municipal Code .....                     | 3-1 |
| 3.2 Agreements with Satellite Agencies ..... | 3-2 |
| 3.3 References .....                         | 3-3 |

## Chapter 4 Element IV: Operations and Maintenance Program

|   |     |
|---|-----|
| 4.1 Collection System Mapping .....                           | 4-1 |
| 4.2 Preventive Operation and Maintenance .....                | 4-2 |
| 4.2.1 Computerized Maintenance Management System (CMMS) ..... | 4-2 |
| 4.2.2 Gravity Sewers .....                                    | 4-2 |
| 4.2.3 CCTV or Video Condition Assessment: .....               | 4-3 |
| 4.2.4 Lift Stations .....                                     | 4-4 |
| 4.2.5 Force Mains .....                                       | 4-5 |
| 4.2.6 Private Sewer Laterals .....                            | 4-5 |
| 4.3 Rehabilitation and Replacement Program .....              | 4-5 |
| 4.4 Training .....  | 4-6 |
| 4.5 Equipment and Replacement Parts .....                     | 4-6 |

## Chapter 5 Element V: Design and Performance Provisions

|   |     |
|---|-----|
| 5.1 Design Criteria for Installation, Rehabilitation and Repair ..... | 5-1 |
| 5.1.1 General .....   | 5-1 |
| 5.1.2 Lift Stations .....   | 5-1 |
| 5.1.3 City Sewer System – Authorized Pipe Materials .....             | 5-2 |
| 5.1.4 Private Sewer Systems and Private Laterals .....                | 5-2 |



**Table of Contents**

5.2 Inspection and Testing Criteria..... 5-2

    5.2.1 New and Rehabilitated Gravity Sewers ..... 5-2

    5.2.2 New and Rehabilitated Manholes ..... 5-3

    5.2.3 New and Rehabilitated Lift Stations ..... 5-3

5.3 References ..... 5-4

**Chapter 6 Element VI: Overflow Emergency Response Plan**

6.1 Purpose ..... 6-1

6.2 Policy ..... 6-1

6.3 Goals ..... 6-2

**Chapter 7 Element VII: Fats, Oils, and Grease (FOG) Control Program**

7.1 Nature and Extent of FOG Problem ..... 7-1

7.2 FOG Source Control Program - Reviews & Inspections ..... 7-2

7.3 Response to GWDR Requirements ..... 7-3

**Chapter 8 Element VIII: System Evaluation and Capacity Assurance Plan**

8.1 System Capacity Evaluation..... 8-1

8.2 Design Criteria ..... 8-2

8.3 Capacity Enhancement Measures - Capital Improvement Program (CIP) ..... 8-2

8.4 References ..... 8-3

**Chapter 9 Element IX: Monitoring, Measurement, and Program Modifications**

9.1 Performance Measures ..... 9-1

9.2 Baseline Performance ..... 9-1

    9.2.1 Mains, Lift Stations, and Force Mains..... 9-1

    9.2.2 Public Laterals (Service or Lower Laterals) ..... 9-5

9.3 Performance Monitoring and Program Changes..... 9-8

9.4 References ..... 9-8

**Chapter 10 Element X: SSMP Program Audits**

10.1 Audits ..... 10-1

10.2 SSMP Updates ..... 10-2

**Chapter 11 Element XI: Communication Program**

11.1 Communication during SSMP Development and Implementation ..... 11-1

11.2 Communication with Satellite Wastewater Collection Systems ..... 11-1

11.3 References ..... 11-1

List of Tables

Table 1. Gravity Sewer Size Distribution ..... I-8

Table 2. Gravity Sewer Materials of Construction ..... I-8

Table 3. Inventory of Gravity Sewer Lines by Pipe Age ..... I-9

Table 4. Roles and Responsibilities Defined ..... 2-2

Table 5. Responsible Officials in Water Quality Chain of Communication ..... 2-4

Table 6. GWDR Legal Authority ..... 3-2

Table 7. Historical Sewer Line Cleaning Results ..... 4-3

Table 8. Historical CCTV of Mains and Laterals ..... 4-3

Table 9. Lift Station Locations and Descriptions ..... 4-4

Table 10. Force Main Descriptions ..... 4-5

Table 11. Sewer Capital Improvement Program (CIP) ..... 4-6

Table 12. Acceptable Pipe Materials for New Gravity Sewers ..... 5-2

Table 13. Historical FOG-Related SSOs in Main Lines ..... 7-1

Table 14. Gravity Main Sewer, Lift Station, and Force Main SSOs by Year ..... 9-2

Table 15. Mainline SSOs by Cause ..... 9-3

Table 16. Mainline SSO Volumes ..... 9-4

Table 17. Public Sewer Lateral SSOs by Cause ..... 9-5

Table 18. Public Sewer Lateral SSO Volumes ..... 9-6

List of Figures

Figure 1. City of Davis Wastewater Service Area ..... I-6

Figure 2. City of Davis Collection System Map ..... I-7

Figure 3. City of Davis Wastewater Division Organization Chart ..... 2-1

Figure 4. SSO Reporting Flow Chart ..... 2-5

Figure 5. Trend in Number of Gravity Sewer, Lift Station, and Force Main SSOs ..... 9-2

Figure 6. Trend in Number of Lateral and Mainline SSOs ..... 9-3

Figure 7. Trend in Gravity Sewer, Lift Station and Force Main SSOs by Cause ..... 9-4

Figure 8. Trend in Volume of Mainline SSOs ..... 9-5

Figure 9. Trend in Cause of Public Sewer Lateral SSOs ..... 9-6

Figure 10. Trend in Volume of Public Sewer Lateral SSOs ..... 9-7

Figure 11. Trend in Rate of SSOs per 100 miles per Year ..... 9-7



## List of Appendices

- Appendix A. Responsible Officials in Water Quality Chain of Communication
- Appendix B. Sewer System Management Plan Council Adoption Documents
- Appendix C. Sewer System Management Plan Change Log
- Appendix D. Sewer System Management Plan Audit Reports
- Appendix E. Lift Station Condition Assessment Checklist
- Appendix F. Sewer System Major Equipment Inventory
- Appendix G. Critical Sewer System Replacement Parts Inventory
- Appendix H. Sanitary Sewer Design Standards
- Appendix I. City Adaptations to Green Book
- Appendix J. FSE Public Outreach Materials
- Appendix K. Sewer System Capital Improvement Program Budget and Schedule
- Appendix L. Overflow Emergency Response Plan

## INTRODUCTION

---

### I.1 INTRODUCTION

This Sewer System Management Plan (SSMP) is a compendium of the policies, procedures, and activities that are included in the planning, management, operation, and maintenance of the City of Davis' (City's) sanitary sewer system.

The State Water Resources Control Board (SWRCB) has issued statewide waste discharge requirements for sanitary sewer systems, which include requirements for development of an SSMP. The SWRCB requirements are outlined in Order No. 2006-0003-DWQ, Statewide General Waste Discharge Requirements for Sanitary Sewer Systems, dated May 2, 2006 (GWDR), and Order No. WQ-2008-0002-EXEC, dated February 20, 2008, which was amended by Order No. 2013-0058-EXEC, effective September 9, 2013, which changed the Monitoring and Reporting Program (MRP). The City currently operates under a Central Valley Regional Water Quality Control Board National Pollution Discharge Elimination System Permit (NPDES) No. CA0079049 issued by Order R5-2013-0127 issued October 4, 2013. The National Pollution Discharge Elimination System Permit NPDES Permit covers both the Davis Wastewater Treatment Plant (WWTP) and the collection system operations. This SSMP is intended to update the City's existing SSMP, in continued compliance with the GWDR.

The structure (section numbering and nomenclature) of this SSMP follows the above referenced GWDR and MRP. This SSMP is organized by the SWRCB outline of elements; and contains language taken from the GWDR as at that beginning of each element. The GWDR uses the term "Enrollee" to mean each individual municipal wastewater agency that has completed and submitted the required application for coverage under the WDR (in this case, the Enrollee is the City). The City's waste discharger identification number in the California Integrated Water Quality System (CIWQS) is 5SSO10921.

### I.2 DEFINITIONS, ACRONYMS, AND ABBREVIATIONS

|                  |   |
|------------------|---|
| BMP              | <b><i>Best Management Practices</i></b><br>Refers to the procedures employed in commercial kitchens to minimize the quantity of grease that is discharged to the sanitary sewer system. Examples include scraping food scraps into a garbage can and dry wiping dishes and utensils prior to washing. |
| Building Lateral | <b><i>See Private Sewer Lateral</i></b>   |
| CCTV             | <b><i>Closed Circuit Television</i></b><br>Refers to the process and equipment that is used to internally inspect the condition of gravity sewers.  |
| CIP              | <b><i>Capital Improvement Program</i></b><br>Refers to the document that identifies future capital improvements to the City's sanitary sewer system.  |
| City             | Refers to the City of Davis   |



|             |  |
|-------------|--|
| CIWQS       | <p><b><i>California Integrated Water Quality System</i></b><br/>Refers to the State Water Resources Control Board online electronic reporting system that is used to report SSOs, certify completion of the SSMP, and provide information on the sanitary sewer system.</p>            |
| CMMS        | <p><b><i>Computerized Maintenance Management System</i></b><br/>Refers to the computerized maintenance management system that is used by the City to plan, dispatch, and record the work on its sanitary sewer system. Lucity™ is the proprietary software the City uses for CMMS.</p> |
| CSA         | <p><b><i>County Service Area</i></b><br/>Areas of Yolo County serviced by the City through agreement. The two areas are El Mercado and North Davis Meadows.</p>  |
| CWEA        | <p><b><i>California Water Environment Association</i></b></p>  |
| CY          | <p><b><i>Calendar Year</i></b></p>   |
| DIP         | <p><b><i>Ductile Iron Pipe</i></b></p>   |
| DS          | <p><b><i>Data Submitters</i></b></p>   |
| FOG         | <p><b><i>Fats, Oils, and Grease</i></b><br/>Refers to fats, oils, and grease typically associated with food preparation and cooking activities that can cause blockages in the sanitary sewer system.</p>  |
| FY          | <p><b><i>Fiscal Year</i></b><br/>Refers to the 12-month periods beginning July 1st and ending June 30th.</p>   |
| FSE         | <p><b><i>Food Service Establishment</i></b><br/>Refers to commercial or industrial facilities where food is handled/prepared/served that discharge to the sanitary sewer system.</p>   |
| GWDR or WDR | <p><b><i>General Waste Discharge Requirements</i></b><br/>Refers to the State Water Resources Control Board Order No. 2006-0003, Statewide General Waste Discharge Requirements for Sanitary Sewer Systems, dated May 2, 2006.</p>   |
| GIS         | <p><b><i>Geographical Information System</i></b><br/>Refers to the City's system that is used to capture, store, analyze, and manage geospatial data associated with the City's sanitary sewer system assets.</p>  |
| GRD         | <p><b><i>Grease Removal Device</i></b><br/>Refers to grease traps and grease interceptors that are installed to remove FOG from the wastewater flow at food service establishments.</p>  |
| Green Book  | <p>Refers to the Standard Specifications for Public Works Construction (2012 or most current version).</p>   |
| I/I         | <p><b><i>Infiltration/Inflow</i></b><br/>Refers to water that enters the sanitary sewer system from storm water and groundwater.</p>   |

|                        |   |
|------------------------|---|
|                        | <p>Infiltration enters through defects in the sanitary sewer system after flowing through the soil.</p> <p>Inflow enters the sanitary sewer without flowing through the soil. Typical points of inflow are holes in manhole lids and direct connections to the sanitary sewer (e.g. storm drains, area drains, and roof leaders).</p> |
| Lateral                | <i>See Private Sewer Lateral</i>  |
| LRO                    | <i>Legally Responsible Official</i><br>Refers to person(s) formally designated by an agency to be responsible for formal reporting and certifying of all reports submitted to the CIWQS.  |
| Lucity™                | Refers to the software used by the City for computerized maintenance management (CMMS).   |
| MH                     | <i>Manhole</i><br>Refers to an engineered structure that is intended to provide access to a sanitary sewer for maintenance and inspection.  |
| Mainline Sewer         | Refers to City wastewater collection system piping that is not a private lateral connection to a user.  |
| Maintenance Hole       | <i>See Manhole</i>  |
| MMPM                   | <i>Monitoring, Measurement, and Plan Modifications</i>  |
| MRP                    | <i>Monitoring and Reporting Program</i><br>State Water Resources Control Board Executive Order WQ 2013-0058-EXEC effective September 9, 2013.   |
| NPDES                  | <i>National Pollution Discharge Elimination System Permit</i>   |
| Notification of an SSO | Refers to the time at which the City becomes aware of an SSO event through observation or notification by the public or other source.   |
| OES                    | <i>Office of Emergency Services</i><br>Refers to the California State Office of Emergency Services.   |
| O&M                    | <i>Operations and Maintenance</i>   |
| OERP                   | <i>Overflow Emergency Response Plan</i>   |
| PM                     | <i>Preventive Maintenance</i><br>Refers to maintenance activities intended to prevent failures of the sanitary sewer system facilities (e.g. cleaning, CCTV, repair, etc.).   |
| Private Sewer Lateral  | Refers to the portion of a private property's building sewer as defined by the plumbing code, and is further defined as the piping of a drainage system that extends from the end of the building drain to the public sewer which includes the connection to the public sewer.  |
| PS                     | <i>Pump Station</i><br>A facility that transmits and lifts sewage into the City gravity sanitary sewer collection system  |



|                                       |  |
|---------------------------------------|--|
| PVC                                   | <i>Polyvinylchloride Pipe</i>  |
| RWQCB                                 | <i>Regional Water Quality Control Board</i><br>Refers to the Central Valley Regional Water Quality Control Board.  |
| SSO                                   | <i>Sanitary Sewer Overflows</i><br>Any overflow, spill, release, discharge or diversion of untreated or partially treated wastewater from a sanitary sewer system. SSOs include: <ol style="list-style-type: none"><li>Overflows or releases of untreated or partially treated wastewater that reach waters of the United States;</li><li>Overflows or releases of untreated or partially treated wastewater that do not reach waters of the United States; and</li><li>Wastewater backups into buildings and on private property that are caused by blockages or flow conditions within the publicly owned portion of a sanitary sewer system.</li></ol> <p>SSOs that include multiple appearance points resulting from a single cause will be considered one SSO for documentation and reporting purposes in CIWQS.</p> <p>Note: Wastewater backups into buildings caused by a blockage or other malfunction of a building lateral that is privately owned are not SSOs.</p> <p>SSO Categories:</p> <p><u>Category 1:</u> Discharge of untreated or partially treated wastewater of any volume resulting from a sanitary sewer system failure or flow condition that either:</p> <ul style="list-style-type: none"><li>Reaches surface water and/or drainage channel tributary to a surface water; or</li><li>Reached a Municipal Separate Storm Sewer System (MS4) and was not fully captured and returned to the sanitary sewer system or otherwise captured and disposed of properly.</li></ul> <p><u>Category 2:</u> Discharge of untreated or partially treated wastewater greater than or equal to 1,000 gallons resulting from a sanitary sewer system failure or flow condition that either:</p> <ul style="list-style-type: none"><li>Does not reach surface water, a drainage channel, or an MS4, or</li><li>The entire SSO discharged to the storm drain system was fully recovered and disposed of properly.</li></ul> <p><u>Category 3:</u> All other discharges of untreated or partially treated wastewater resulting from a sanitary sewer system failure or flow condition.</p> |
| Sanitary Sewer System or Sewer System | Refers to the sanitary sewer facilities that are owned and operated by the City of Davis.  |
| SSMP                                  | <i>Sewer System Management Plan</i>  |
| SOP                                   | <i>Standard Operating Procedures</i><br>Refers to written procedures that pertain to specific activities employed in the operation and maintenance of the Sanitary Sewer System.   |

## Introduction

---

|                         |   |
|-------------------------|---|
| Standard Specifications | <i>See “Green Book” above</i>   |
| SWRCB                   | <p><b><i>State Water Resources Control Board</i></b></p> <p>Refers to the California Environmental Protection Agency, State Water Resources Control Board.</p> <p>Note: The State Board is a separate entity from the Central Valley Regional Water Quality Control Board, although the two agencies are closely connected.</p> |
| SCADA                   | <p><b><i>Supervisory Control and Data Acquisition</i></b></p> <p>Refers to the system that is employed by the City to monitor the performance of its lift stations and to notify the operating staff when there is an alarm condition that requires attention.</p>  |
| SECAP                   | <b><i>System Evaluation and Capacity Assurance Plan</i></b>   |
| VCP                     | <b><i>Vitrified Clay Pipe</i></b>   |
| Water of the State      | Refers to “any surface water or groundwater, including saline waters, within the boundaries of the state.” (California Water Code § 13050(e)).  |
| WWTP                    | <b><i>Wastewater Treatment Plant</i></b>  |

### I.3 SANITARY SEWER SYSTEM FACILITIES

The City operates a sanitary sewer system that serves a population of approximately 66,622 in a 10.5 square mile service area. The City’s wastewater service area, shown on Figure 1, includes two Yolo County Service Areas, North Davis Meadows and El Macero. The sewer system serves 14,800 residential connections and 540 commercial, industrial and institutional customers as of 2014. Figure 2 contains an overview map of the City’s sanitary sewer system. The system consists of 160 miles of gravity sewers (approximately 3,300 line segments), 2,700 manholes, 6 pump stations and 2.63 miles of force mains ranging in size from four to 14 inches. The sewer mains range in size from six to 66 inches in diameter. Approximately 20 percent of the sewer mains are located in easements granted to the City. The City also provides service to two extraterritorial service areas, Teichert Construction Corporation Yard and the Royal Oaks Mobile Home Park, by individual agreements.

I:\125\_DAVIS\125-0402\FG2-1.dwg 9-14-05 01:51:29 PM jSeebach

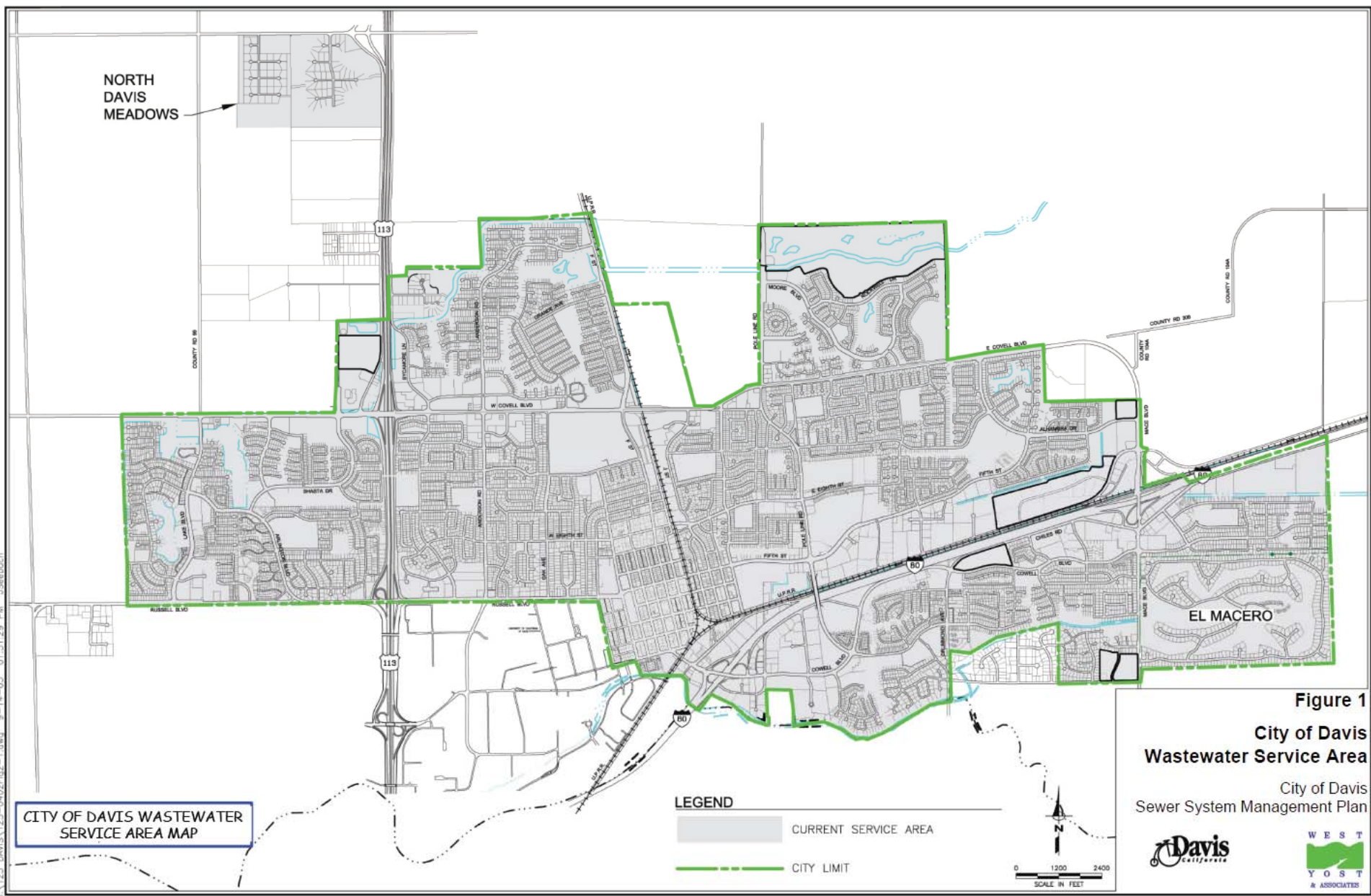



CITY OF DAVIS WASTEWATER SERVICE AREA MAP

**LEGEND**

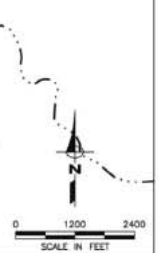
- CURRENT SERVICE AREA
- CITY LIMIT



**Figure 1**  
**City of Davis**  
**Wastewater Service Area**  
 City of Davis  
 Sewer System Management Plan



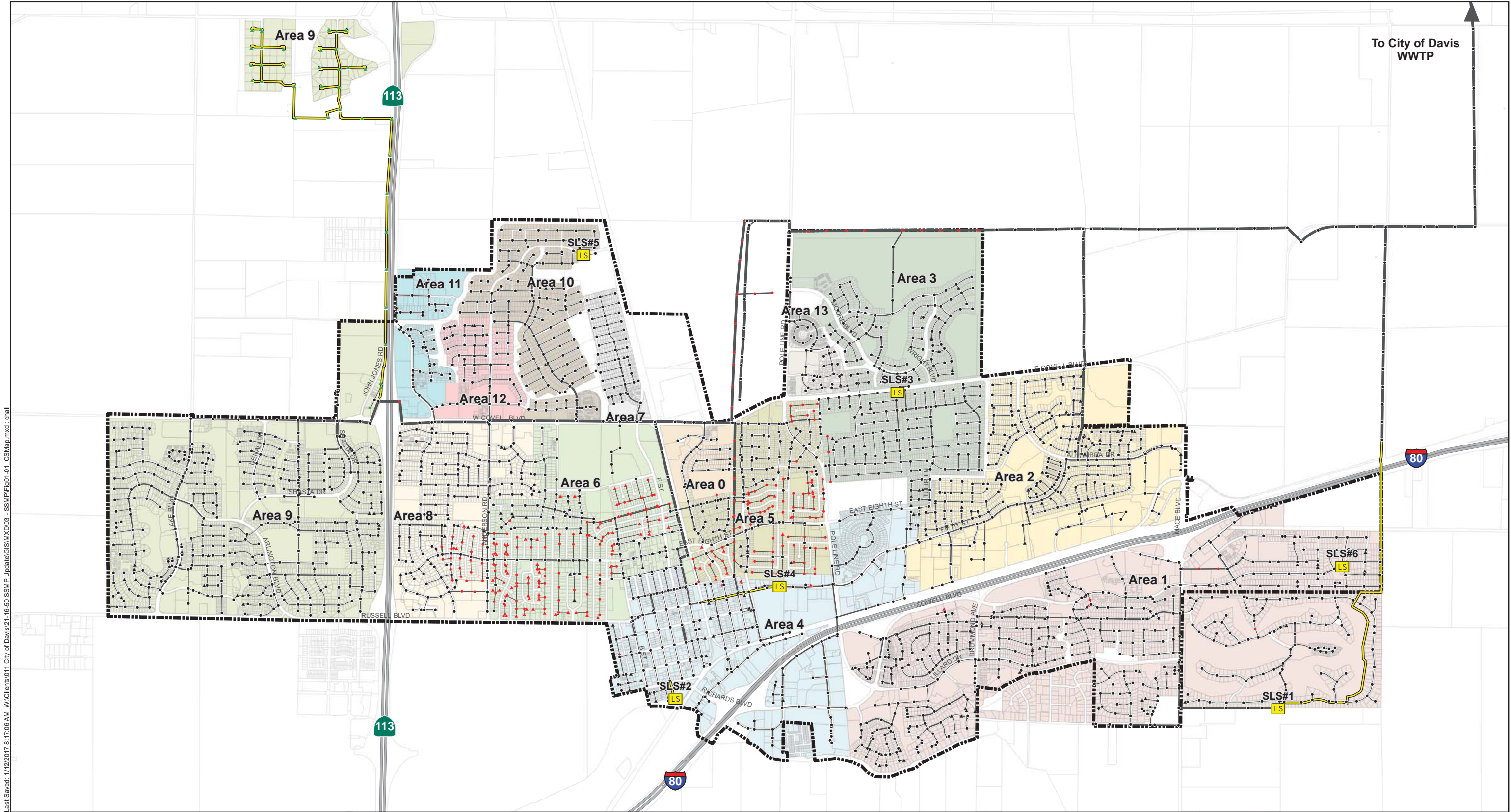

Last Saved: 1/12/2017 8:17:06 AM W:\Clients\011 City of Davis\21-16-50 SSMP Update\GIS\MXD\03 - SSMP\Fig01-01\_CSMMap.mxd - chail

- Symbology**
- City Limits
  - Wastewater Collection System**
    - Gravity Cleanout
    - Backyard Gravity Cleanout
    - Pressure Cleanout
    - Manhole
    - Backyard Manhole
    - Private Manhole

- Active Lift Station
- Force Main
- Gravity Line Diameter**
  - ≤ 8 inches
  - 9 inches - 18 inches
  - ≥ 21 inches

- Maintenance Area**
- 0
  - 1
  - 2
  - 3
  - 4
  - 5
  - 6
  - 7
  - 8
  - 9
  - 10
  - 11
  - 12
  - 13

Notes:  
1. City GIS received 9/2014

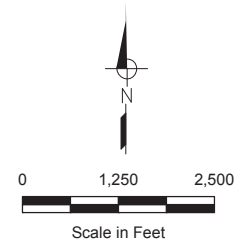

**Figure 2**  
**City of Davis**  
**Collection System Map**  
City of Davis  
Sewer System Management Plan

Table 1 and Table 2 provide the composition of the sewer piping by size and material of construction, and Table 3 provides the installation age distribution of the City's collection system.

| <b>Table 1. Gravity Sewer Size Distribution</b> |                         |                          |  |
|---|-------------------------|--------------------------|--|
| Diameter, inches                                | Number of Line Segments | Pipe Length, linear feet | Portion of Sewer System, % (by length) |
| 6   | 1,272                   | 320,071                  | 38.2%                                  |
| 8   | 1,002                   | 282,224                  | 33.7%                                  |
| 10  | 266                     | 73,656                   | 8.8%                                   |
| 12  | 132                     | 36,515                   | 4.4%                                   |
| 15  | 80                      | 25,822                   | 3.1%                                   |
| 18  | 33                      | 10,550                   | 1.3%                                   |
| 21  | 39                      | 14,982                   | 1.8%                                   |
| 24  | 31                      | 12,153                   | 1.5%                                   |
| 27  | 4                       | 2,265                    | 0.3%                                   |
| 30  | 11                      | 5,092                    | 0.6%                                   |
| 36  | 3                       | 867                      | 0.1%                                   |
| 42  | 55                      | 25,169                   | 3.0%                                   |
| 48  | 14                      | 7,103                    | 0.8%                                   |
| 66  | 1                       | 720                      | 0.1%                                   |
| Unknown   | 108                     | 20,197                   | 2.4%                                   |
| <b>Total</b>                                    | <b>3,051</b>            | <b>837,387</b>           | <b>100.0%</b>                          |

*Source: City Lucity™ CMMS Program, May 2016*

| <b>Table 2. Gravity Sewer Materials of Construction</b> |                 |                    |                         |
|---|-----------------|--------------------|-------------------------|
| Material  | Pipe Length, LF | Pipe Length, miles | Percent of Sewer System |
| VCP   | 835,447         | 158.2              | 99.8%                   |
| RCP   | 30              | 0.0                | 0.0%                    |
| Unknown   | 1,910           | 0.4                | 0.2%                    |
| <b>Total</b>  | <b>837,387</b>  | <b>158.6</b>       | <b>100.0%</b>           |

*Source: City Lucity™ CMMS Program, May 2016*



**Table 3. Inventory of Gravity Sewer Lines by Pipe Age**

| Age in Years             | Construction Period | Percent of Sewer System | Pipe Length, LF |
|--------------------------|---------------------|-------------------------|-----------------|
| 0-15                     | 2000 - current      | 10                      | 84,480          |
| 16 – 35                  | 1980 – 1999         | 45                      | 380,160         |
| 36 – 55                  | 1960 – 1979         | 25                      | 211,200         |
| 56 – 75                  | 1940 – 1959         | 10                      | 84,480          |
| 76 – 95                  | 1920 – 1939         | 5                       | 42,240          |
| 95 – 115                 | 1900 – 1119         | 5                       | 42,240          |
| >115                     | Before 1900         | 0                       | 0               |
| <b>Total Linear Feet</b> |                     |                         | <b>844,800</b>  |
| <b>Total Miles</b>       |                     |                         | <b>160</b>      |

*Source: CIWQS Operational Performance Report, October 2015*

#### I.4 REFERENCES

*State Water Resources Control Board Order No. 2006-0003*, Statewide General Waste Discharge Requirements for Sanitary Sewer Systems, California State Water Resources Control Board, May 2, 2006.

*State Water Resources Control Board Order No. Order No. 2013-0058-EXEC*, Amending Monitoring and Reporting Program for Statewide General Waste Discharge Requirements for Sanitary Sewer Systems, September 9, 2013.

*Central Valley Regional Water Quality Control Board Order No. R5-2013-0127, NPDES Permit No. CA0079049*, Wastewater Discharge requirements for the City of Davis Wastewater Treatment Plant, Yolo County adopted October 4, 2013. Permit Section C5(c).

**State Resources Water Control Board (SWRCB) Waste Discharge Requirement:**

The purpose of the Sewer System Management Plan (SSMP) is to provide a plan and schedule to properly manage, operate, and maintain all parts of the sanitary sewer system. This will help reduce and prevent Sanitary Sewer Overflows (SSOs), as well as mitigate any SSOs that do occur.

**1.1 SSMP GOALS**

The goals of the City of Davis (City) SSMP are:

- To execute the basic plan of routine maintenance, designed to preclude interruption of service throughout the collection system;
- To properly manage, operate, and maintain all portions of the City’s wastewater collection system;
- To immediately investigate all complaints, with prompt correction of faulty conditions on the collection system infrastructures;
- To continue routine inspection for physical damage to the collection system supplemented by immediate and adequate repair of any damage and eliminations of the cause;
- To reduce, prevent and mitigate the impacts of SSOs;
- To conduct all operation with due consideration to protect the public health, worker safety and the environment;
- To involve employees in the strategic planning process for the collection system; and
- To recognize the ownership of the system by the public, to be manifested by courteous, efficient and business like performance of all collection system operations and functions.

**SWRCB Waste Discharge Requirement:**

The SSMP must identify:

- a. The name of the responsible or authorized representative as described in Section J of this Order.
- b. The names and telephone numbers for management, administrative, and maintenance positions responsible for implementing specific measures in the SSMP program. The SSMP must identify lines of authority through an organization chart or similar document with a narrative explanation; and
- c. The chain of communication for reporting SSOs, from receipt of a complaint or other information, including the person responsible for reporting SSOs to the State and Regional Water Board and other agencies if applicable (such as County Health Officer, County Environmental Health Agency, Regional Water Board, and/or State Office of Emergency Services (OES)).

**2.1 ORGANIZATIONAL STRUCTURE**

The organization chart for the management, operation, and maintenance of the City’s wastewater collection system is shown on Figure 3.

**Figure 3. City of Davis Wastewater Division Organization Chart**

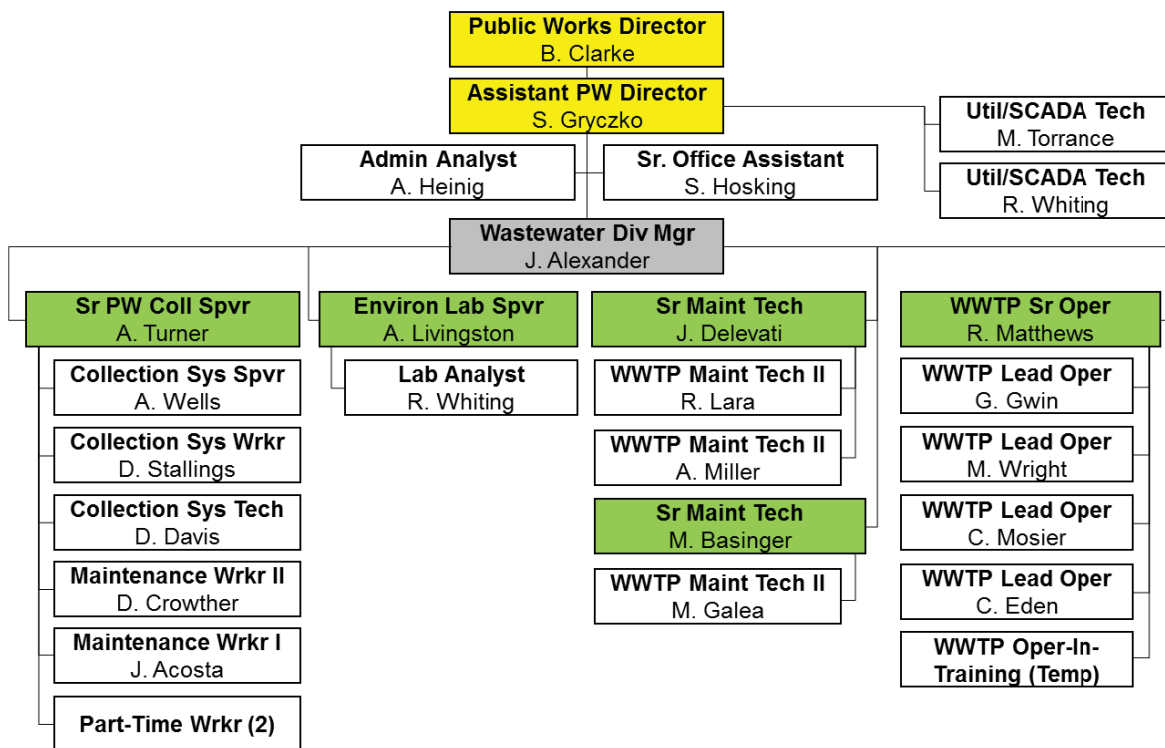

## 2.2 AUTHORIZED REPRESENTATIVES

The City’s Legally Responsible Officials (LRO) and Data Submitters (DS) for wastewater collection system matters are identified in Table 4 along with their roles and responsibilities for the collection system operations. They are authorized to submit electronic and written spill reports to the OES. They are the City’s LROs who are authorized to certify electronic spill reports and other required submittals to the SWRCB.

| <b>Table 4. Roles and Responsibilities Defined</b>              |   |
|---|---|
| Position  | Roles and Responsibilities  |
| <b>City Council</b>   | Establishes policy.   |
| <b>City Manager</b>   | Plans, organizes and directs the overall administrative activities and operations of the City. Advises and assists the City Council, represents the City’s interest with other governmental agencies, business interests, and the community.  |
| <b>General Manager of Utilities, Development and Operations</b> | Provides general direction and oversight of the utility regulatory compliance activities to ensure compliance with local, state and federal laws and regulations.   |
| <b>City Engineer</b>  | Plans, coordinates, supervises, and participates in the performance of professional engineering activities of a complex nature involving engineering planning and design, construction project management.  |
| <b>Public Works Director</b>                                    | Plans, directs, organizes, coordinates, supervises and reviews the activities of the divisions comprising the Public Works Department; and provides highly responsible professional and technical staff assistance to the City Manager.   |
| <b>Assistant Public Works Director (LRO)</b>                    | Provides complex professional managerial assistance to the Public Works Director in the development and administration of City programs, and implementation through subordinate staff; provides professional and technical engineering support relative to assigned area of responsibility; and represents the Public Works Director as required or assigned.                       |
| <b>Wastewater Division Manager (LRO)</b>                        | Directs, oversees, supervises, organizes and coordinates the operations, laboratory and maintenance of the City’s Wastewater Division consisting of the wastewater treatment plant and collection system.   |
| <b>Senior Public Works Collections Supervisor (DS)</b>          | Plan, organizes, and directs the activities of the Sewer/Stormwater Collections section and to provide technical assistance to public works management staff.   |
| <b>Collections System Supervisor (DS)</b>                       | Plans, coordinates, lays out the work assignments and supervises the work of a number of crews involved in the operation and maintenance of wastewater and storm sewer systems, and provides technical staff assistance.  |
| <b>Senior Utility Program Technician (SCADA)</b>                | Performs technical office or field engineering work. Specifically manages Supervisory Control and Data Acquisition (SCADA) to perform data collection and control, oversees the day-to-day operation, maintenance and repair/replacement of pump stations, and manages flow monitoring activities for infiltration/inflow studies, capacity studies and wastewater flow monitoring. |

**Table 4. Roles and Responsibilities Defined**

| Position                                   | Roles and Responsibilities   |
|--|--|
| <b>Environmental Inspector</b>             | Oversees the pretreatment program and the Fats, Oils, and Grease (FOG) program under direction of the WWTP Superintendent. Performs water quality assessments and special studies associated with the sanitary sewer. Lead role in implementation the City's FOG program. Coordinates and confers with federal and state regulatory agencies as well as with the Collections Division, consultants, and directly with sewer users to ensure compliance with regulations and related reporting requirements. Prepares reports and communicates as needed with the public, commissions and the sewer users. Provides backup for the City's Stormwater Program. |
| <b>Collection Systems Technician</b>       | Participates in maintenance and repair duties and performs a wide variety of skilled and semi-skilled maintenance, construction, and repair work, and operates light and moderately heavy power driven equipment.  |
| <b>Senior Engineering Technician</b>       | Provides engineering and technical support to the Wastewater Division involving researching and collecting data, creating and maintaining a geographical information system (GIS) mapping system in support of engineering and operational work activities, responsible for creating, collecting, compiling, manipulating and maintaining data for various GIS applications.   |
| <b>Electrician</b>                         | Under direction, performs skilled work in the installation, maintenance and repair of electrical wiring and related apparatus, components of the WWTP, water utility, traffic signals, sanitary and storm collections systems and street light installations, and to conduct electrical inspections of City buildings.   |
| <b>WWTP Senior Maintenance Technician</b>  | Leads, maintains and repairs wastewater treatment plant, wetlands, lift station equipment and drainage facilities.   |
| <b>WWTP Maintenance Technician II</b>      | Performs a variety of semi-skilled and skilled tasks to insure the operation, maintenance and repair of treatment plant, sewer lift and storm drainage equipment, buildings, grounds and structures.   |
| <b>Administrative Analyst I/II</b>         | Provides responsible, professional administration and technical assistance in the development, administration, and implementation of City programs; provides highly responsible administrative staff assistance including conducting specific and comprehensive analyses of a wide range of municipal policies involving organization, procedures, finance and services; and assists in basic office management functions such as developing and monitoring a department budget, administering contracts, and monitoring and administering project grants.   |
| <b>Environmental Laboratory Supervisor</b> | Supervises and administers the City's environmental laboratory and provides direction for the laboratory service program, including the Laboratory Information Management System, Chemical Hygiene Plan, and Quality Assurance/Quality Control program. Provides support with permitting activities for City programs, including wastewater, water, pretreatment, and stormwater.  |
| <b>Environmental Program Specialist</b>    | Coordinates, implements, conducts, analyzes, and maintains the wastewater pretreatment program, stormwater quality discharge program or other environmental programs at a level of service that enables compliance with mandates and facilitates the protection of water quality.  |



**Table 4. Roles and Responsibilities Defined**

| Position             | Roles and Responsibilities   |
|----------------------|--|
| <b>City Engineer</b> | Plans, coordinates, and supervises the work of staff in a division or multiple divisions within the Public Works Department; to provide professional and technical engineering support relative to assigned area of responsibility; to serve as the City Engineer and to administer the programs of the assigned division(s). Provides complex professional managerial assistance to the Public Works Director in the development and administration of professional engineering activities of a complex nature involving engineering planning and design related to the sanitary sewer collection system. |

### 2.3 RESPONSIBILITY FOR SSMP IMPLEMENTATION AND MAINTENANCE

The Senior Public Works Collections Supervisor shall have the overall responsibility for, implementing, periodically auditing, and maintaining the City’s SSMP. He/she may delegate these responsibilities to his/her staff.

Other City staff responsible for developing, implementing, and maintaining specific elements of the City’s SSMP are identified by job title in Table 5. Names and contact information are included in Appendix A.

**Table 5. Responsible Officials in Water Quality Chain of Communication**

| Element    | Element Name                                      | Responsible City Official           |
|------------|---|-------------------------------------|
| -          | Introduction                                      | Wastewater Division Manager         |
| 1          | Goals   | Wastewater Division Manager         |
| 2          | Organization                                      | Wastewater Division Manager         |
| 3          | Legal Authority                                   | Wastewater Division Manager         |
| 4          | Operations and Maintenance Program                | Senior Collections Supervisor       |
| 5          | Design and Performance Provisions                 | City Engineer                       |
| 6          | Overflow Emergency Response Plan                  | Senior Collections Supervisor       |
| 7          | FOG Control Program                               | Environmental Laboratory Supervisor |
| 8          | System Evaluation and Capacity Assurance Plan     | City Engineer                       |
| 9          | Monitoring, Measurement and Program Modifications | Wastewater Division Manager         |
| 10         | Program Audits                                    | Wastewater Division Manager         |
| 11         | Communications Program                            | Wastewater Division Manager         |
| Appendix A | Responsible Officials Contact Information         | Wastewater Division Manager         |
| Appendix B | SSMP Council Adoption Documents                   | Assistant Public Works Director     |
| Appendix C | SSMP Change Log                                   | Wastewater Division Manager         |
| Appendix D | SSMP Audit Reports                                | Wastewater Division Manager         |

## 2.4 SSO REPORTING CHAIN OF COMMUNICATION

The SSO Reporting Chain of Communication follows the flow chart shown on Figure 4. The SSO Reporting process and responsibilities are also described in detail in the Overflow Emergency Response Plan in Element IV.

**Figure 4. SSO Reporting Flow Chart**

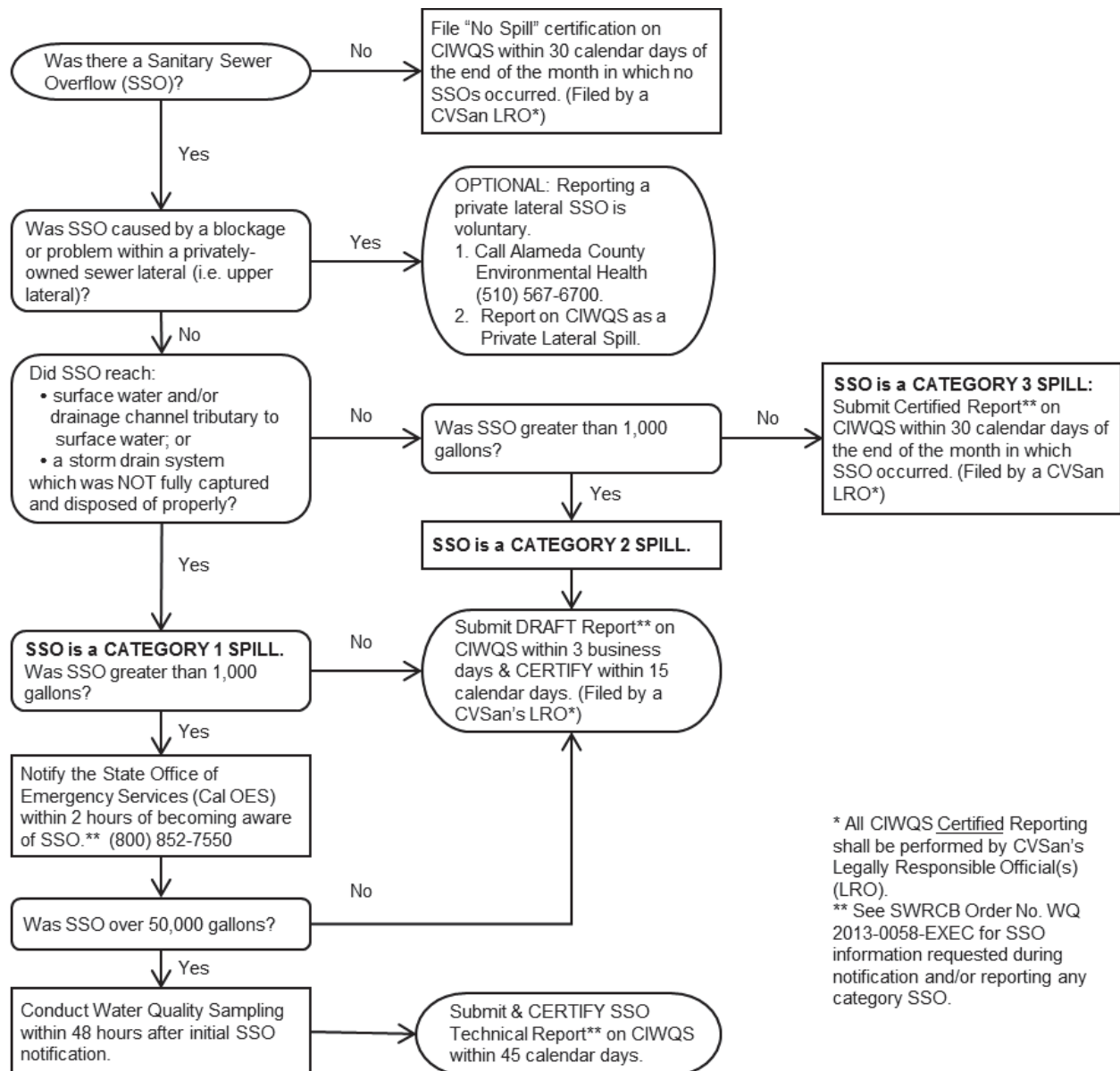

\* All CIWQS Certified Reporting shall be performed by CVSan's Legally Responsible Official(s) (LRO).  
\*\* See SWRCB Order No. WQ 2013-0058-EXEC for SSO information requested during notification and/or reporting any category SSO.

**SWRCB Waste Discharge Requirement:**

Each Enrollee must demonstrate, through sanitary sewer system use ordinances, service agreements, or other legally binding procedures, that it possesses the necessary legal authority to:

- a. Prevent illicit discharges into its sanitary sewer system (examples may include infiltration and inflow (I/I), stormwater, chemical dumping, unauthorized debris and cut roots, etc.);
- b. Require that sewers and connections be properly designed and constructed;
- c. Ensure access for maintenance, inspection, or repairs for portions of the lateral owned or maintained by the Public Agency;
- d. Limit the discharge of FOG and other debris that may cause blockages; and
- e. Enforce any violation of its sewer ordinances.

**3.1 MUNICIPAL CODE**

The City's Municipal Code is available online (<http://qcode.us/codes/davis/>) and describes the City's current legal authority required for compliance with the General Waste Discharge Requirements (GWDR). That authority is specifically contained within Chapter 33 Sewers and Sewage Disposal of the Municipal Code and generally within other Municipal Code Titles that are summarized in Table 6.

| <b>Table 6. GWDR Legal Authority</b>   |  |
|--|--|
| Requirement  | Legal Authority Reference  |
| Prevent illicit discharges into the wastewater collection system   | 33.03.050  |
| Limit the discharge of fats, oils, and grease and other debris that may cause blockages  | 33.03.030; 33.03.050(b)(2); 33.03.040                                |
| Require that sewers and connections be properly designed and constructed   | 33.02.030; 33.02.020; 33.02.050;                                     |
| Require proper installation, testing, and inspection of new and rehabilitated sewers   | 36.09.020  |
| Clearly define City responsibility and policies for sewer laterals   | None to be added to municipal code in the coming year                |
| Ensure access for maintenance, inspection, or repairs for portions of the service lateral owned or maintained by the City  | 33.02.050; 33.03.430; 33.04.110;<br>Sewer Lateral Maintenance Policy |
| Control I/I from private service laterals  | 33.02.050(b)(16)   |
| Requirements to install grease removal devices (such as traps or interceptors), design standards for the grease removal devices, maintenance requirements, Best Management Practices (BMP) requirements, record keeping and reporting requirements | 33.01.020; 33.03.030; 33.03.165; 8.01.010(a)(6);<br>8.01.060         |
| Authority to inspect grease producing facilities   | 33.03.310; 33.03.430; 33.04.110                                      |
| Enforce any violation of its sewer ordinances  | 33.06.070; 33.03.370 et seq.   |

### 3.2 AGREEMENTS WITH SATELLITE AGENCIES

The City has two extraterritorial service areas that discharge to the Davis Wastewater Treatment Plant (WWTP). All of these areas have agreements with the City for either operations and maintenance or acceptance of waste through the Davis collection system and for treatment and disposal at the WWTP. The two extraterritorial service areas are the Teichert Construction Corporation Yard and the Royal Oaks Mobile Home Park.

### 3.3 REFERENCES

The following information was used to develop this Element:

- City of Davis Municipal Code Chapters 8 and 33.
- Agreement for Sewage Collection and Treatment (El Macero Sewer Interceptor Project) dated April 7, 1975 with Amendments in 2013 and 2015.
- Agreement for Sewer Treatment Service, Contribution to Sewer Collection System and Sewer System Maintenance in North Davis Meadows dated May 19, 1998.
- Sewer Agreement Between City of Davis and A. Teichert & Sons, Inc. Dated November 14, 2006.
- Agreement for Sewer Services Royal Oaks Mobile Home Park July 1985 with First and Second Amendments, 1988 and 2013.
- Public Information Handout, Sewer Lateral Maintenance Procedure February 2017.



**SWRCB Waste Discharge Requirement:**

The Sewer System Management Plan (SSMP) must include those elements listed below that are appropriate and applicable to the Enrollee's system:

- a. Maintain an up-to-date map of the sanitary sewer system, showing all gravity line segments and manholes, pumping facilities, pressure pipes and valves, and applicable stormwater conveyance facilities;
- b. Describe routine preventive operation and maintenance activities by staff and contractors, including a system for scheduling regular maintenance and cleaning of the sanitary sewer system with more frequent cleaning and maintenance targeted at known problem areas. The Preventive Maintenance (PM) program should have a system to document scheduled and conducted activities, such as work orders;
- c. Develop a rehabilitation and replacement plan to identify and prioritize system deficiencies and implement short-term and long-term rehabilitation actions to address each deficiency. The program should include regular visual and TV inspections of manholes and sewer pipes, and a system for ranking the condition of sewer pipes and scheduling rehabilitation. Rehabilitation and replacement should focus on sewer pipes that are at risk of collapse or prone to more frequent blockages due to pipe defects. Finally, the rehabilitation and replacement plan should include a capital improvement plan that addresses proper management and protection of the infrastructure assets. The plan shall include a time schedule for implementing the short- and long-term plans plus a schedule for developing the funds needed for the capital improvement plan;
- d. Provide training on a regular basis for staff in sanitary sewer system operations and maintenance, and require contractors to be appropriately trained; and provide equipment and replacement part inventories, including identification of critical replacement parts.

#### 4.1 COLLECTION SYSTEM MAPPING

Each Collections field crew has an atlas map book of collection system facilities. The map book includes information on main lines, maintenance holes, and pump stations. The map is organized by map grids or quadrants and shows maintenance hole numbers, field-verified maintenance hole depths and pipe diameters, and in some cases-flow arrows. Crews also have CAD-based utility maps that indicate storm drainage facility locations, for use in SSO events.

The City Engineering Division is working with the Collections Division to develop a GIS-based collection system map book, which will also include rim and invert elevation data, where available. The City will ultimately have many layers in GIS available for Collections operations and maintenance, such as planning, scheduling, cleaning, repairs, and other maintenance activities. This will enable both the recording and tracking of all these Collections work items.

All Collections field staff are responsible for documenting necessary revisions to the map books when they discover discrepancies in their fieldwork. The Senior Public Works Collections Supervisor is responsible for communicating any needed revisions to the Engineering Division, who is responsible for revising the GIS and CAD-based map books. Each of the three field crews is equipped with hard copies of map books and a laptop that will for access to these map books in the future, as well as for field access to work orders.

## 4.2 PREVENTIVE OPERATION AND MAINTENANCE

The elements of the City's sewer system O&M program include:

- Proactive, preventive, and corrective maintenance of gravity sewers;
- Closed circuit television (CCTV) inspection program to determine the condition of the gravity sewers;
- Rehabilitation and replacement of sewers that are in poor condition.

### 4.2.1 Computerized Maintenance Management System (CMMS)

The City uses Lucity™ as its CMMS to manage its collection system maintenance program. All collection system assets (sewers, maintenance holes and pump stations) are identified in the CMMS, as are the size and lengths of the sewers. The CMMS is also used to schedule, generate, and record work orders. The CMMS is used as the repository for asset history and also stores labor hours for work orders. Field crews have laptops for field access to the work orders.

### 4.2.2 Gravity Sewers

Collections crews proactively clean all pipes 4 inches to 21 inches in diameter. The core area of the system is performed on a quarterly schedule. Backyard easement cleaning is performed on an annual basis. The City is currently developing a schedule to clean the remainder of the system on a 3- to 5-year schedule. The City also maintains service laterals (lower laterals) and takes responsibility for these laterals when they are blocked and/or cause sanitary sewer overflows (SSOs).

Cleaning crews operate a combination cleaning units (a high pressure water jetting truck and a rodder) and a hydroflusher, which can also be used for easement areas with limited access to clean sewer lines.

In general, hydrojetting is utilized for cleaning and maintenance, supplemented by rodding and root cutting where required. The downtown core area has a high concentration of food service establishments (FSEs) that generate significant amounts of FOG, and is consequently cleaned quarterly. Backyard easement lines are scheduled for annual cleaning, and the remainder of the less than 21 inch pipes are cleaned approximately every 3- to 5-years.

The City also provides reactive maintenance, which are typically the result of service calls from staff or the public. Quick response from Collections staff often prevent potential SSOs from occurring, since staff can sometimes clear blockages before an SSO occurs. Collections staff can also minimize the impact of SSOs that do occur by containing and recovering the SSO volume as quickly as possible.

Collections field crews are all equipped with the City's Wastewater Collections Division Binder, an extensive compilation of standard operating procedures (SOP), standards, guides, and forms. The binder outlines expectations, responsibilities, and expected production rates for work items.

The historical sewer line cleaning results are shown in Table 7. Large diameter pipes above 21 inches in diameter should be videoed every 5 years to check condition. If determined necessary, these large diameter lines will be cleaned using service contractors rather than City staff.

| Fiscal Year | Line Cleaning, feet | Line Cleaning, miles | Percent of System |
|-------------|---------------------|----------------------|-------------------|
| 2015        | 396,000             | 75                   | 46.9              |
| 2014        | 404,044             | 76.5                 | 47.8              |
| 2013        | 316,328             | 59.9                 | 37.4              |
| 2012        | 330,598             | 62.6                 | 39.1              |
| 2011        | 425,467             | 80.6                 | 50.4              |

The City inspects manholes at the time of cleaning operations. All problem conditions found are then either repaired by Collections staff or contracted for repairs by service contractors.

**4.2.3 CCTV or Video Condition Assessment:**

The City uses CCTV camera units to visually inspect portions of the sanitary sewer system. Currently, CCTV inspection is generally performed on lines subsequent to SSO events or problem maintenance areas only. Results of this CCTV work sometimes lead to main line and lateral repairs. The City is currently reviewing its CCTV needs, including the purchase of new CCTV equipment, use of contractors, and increasing the amount of inspection work that is needed. Existing equipment and practices only include a video inspection, with no coding of defects. Additionally, the videos are only available on the CCTV truck, and cannot be downloaded for backup or viewing on a separate machine. The historical results of the City CCTV efforts are shown in Table 8.

| Calendar Year | Laterals - CCTV, feet | Mains - CCTV, feet |
|---------------|-----------------------|--------------------|
| 2015          | 45,000                | 2,522              |
| 2014          | 16,200                | 19,687             |
| 2013          | 11,745                | 1,610              |
| 2012          | 8,370                 | 7,641              |
| 2011          | 4,815                 | 8,107              |

#### 4.2.4 Lift Stations

The City operates and maintains lift stations, as shown on Figure 2 and described in Table 9. Each of the six lift stations discharge to force mains.

| Table 9. Lift Station Locations and Descriptions |                          |           |                   |                 |                   |         |                                       |
|--|--------------------------|-----------|-------------------|-----------------|-------------------|---------|---------------------------------------|
| Pump Station Name                                | Location                 | No. Pumps | Construction Year | Pump GPM        | Pump Manufacturer | Pump HP | Standby Generation, kW <sup>(a)</sup> |
| SLS#1  | 44501 S. El Macero Dr.   | 3         | 1975              | 900             | Fairbanks Morse   | 24.1    | 60 (on-site)                          |
| SLS#2  | 500 First St.            | 2         | 1996              | 200             | Flygt             | 3       | 30                                    |
| SLS#3  | 1818 Manzanita           | 2         | 1964              | 900             | Smith & Loveless  | 15      | 30                                    |
| SLS#4  | 1717 5 <sup>th</sup> St. | 2         | 1971              | 2,055/<br>1,800 | Smith & Loveless  | 25      | 250                                   |
| SLS#5  | 3434 Anderson Rd.        | 2         | 1992              | 200             | Flygt             | 3.2     | 250                                   |
| SLS#6  | 5454 Cowell Blvd.        | 2         | 1997              | 200             | Flygt             | 2.4     | 30                                    |

<sup>(a)</sup> Standby generation is portable unless otherwise noted.

The City conducts regular maintenance inspections of its lift stations once per week. Regular PM is performed at the stations on a quarterly basis by WWTP maintenance staff. City WWTP maintenance staff perform electrical and/or controls maintenance and repairs at each station. The checklist used during these regular inspections is provided as Appendix E.

Standby alarms are connected through a SCADA system to the WWTP control center so quick response to problems can be made.

#### 4.2.5 Force Mains

The City does not currently have a force main inspection program. Table 10 lists the force main asset information. Many of the force mains were installed at the time of the original construction of the associated lift stations.

| <b>Table 10. Force Main Descriptions</b>        |                              |              |                     |
|---|------------------------------|--------------|---------------------|
| Name of Lift Station Associated with Force Main | Force Main Asset Information |              |                     |
|   | Material Type                | Size, inches | Length, linear feet |
| SLS#1   | Ductile Iron Pipe (DIP)      | 14           | 10,113              |
| SLS#2   | DIP                          | 4            | 519                 |
| SLS#3   | DIP                          | 10           | 153                 |
| SLS#4   | DIP                          | 14           | 2,154               |
| SLS#5   | DIP                          | 4            | 275                 |
| SLS#6   | DIP                          | 4            | 678                 |
| Total   |                              |              | 13,882              |

#### 4.2.6 Private Sewer Laterals

The City has no responsibility for the installation, maintenance, operation, repair or replacement of private sewer laterals connected to the City sewer mains unless a previous overflow has occurred in the lower lateral, at which point the City maintains the lower lateral. The City utilizes chemical treatment for root control in these laterals that have previously had an SSO. This program was previously suspended due to concerns about herbicides, but was reinstated in 2016 using less toxic products. Approximately 300 laterals are currently receiving City maintenance.

The City has a private sewer lateral policy that can be found on the City website at: <http://cityofdavis.org/Home/ShowDocument?id=5025>.

#### 4.3 REHABILITATION AND REPLACEMENT PROGRAM

The City has an annual sewer rehabilitation and replacement program to rehabilitate or replace the portions of its wastewater collection system and lift station assets where and when conditions warrant. The annual budgets for all lift station and sewer projects that are included in the City's Annual Budget are listed in Table 11.



| <b>Table 11. Sewer Capital Improvement Program (CIP)</b> |                 |
|--|-----------------|
| Fiscal Year  | Budget, dollars |
| 2016   | 2,150,000       |
| 2017   | 2,050,000       |
| 2018   | 2,050,000       |
| 2019   | 2,050,000       |
| 2020   | 2,050,000       |
| 2021   | 2,050,000       |
| 2022   | 1,650,000       |
| 2023   | 1,650,000       |
| 2024   | 850,000         |
| 2025   | 850,000         |
| Totals   | \$17,400,000    |

In addition to the CIP budget shown the collection system staff allocates approximately \$350,000 per year to conducting in-house repairs of the wastewater collection system.

#### 4.4 TRAINING

The City uses a combination of in-house classes, field exercises, on-the-job training, and attendance at conferences, seminars, California Water Environment Association (CWEA) classes and other training opportunities that are provided in Northern California. The City highly recommends its wastewater collection system employees be certified in Collection System Maintenance by CWEA, and all but the most recently-hired individual staff member is certified as CWEA Collection System Maintenance Grade 1 or higher.

In addition, the City conducts annual confined space entry certification for all employees that might be required to enter confined spaces anywhere in the City. Finally, the City conducts frequent tailgate meetings with all collections system staff to discuss topics related to safety, operations and performance expectations. O&M procedures and responsibilities are clearly defined, documented, and conveyed to Collections staff through the aforementioned Wastewater Collections Division Binder that all crews possess.

#### 4.5 EQUIPMENT AND REPLACEMENT PARTS

The list of the major equipment that City uses in the operation and maintenance of its sewer system is included in Appendix F. The City has developed an inventory of critical replacement parts that is included in Appendix G.

**SWRCB Waste Discharge Requirement:**

1. Design and construction standards and specifications for the installation of new sanitary sewer systems, lift stations and other appurtenances; and for the rehabilitation and repair of existing sanitary sewer systems; and
2. Procedures and standards for inspecting and testing the installation of new sewers, pumps, and other appurtenances and for rehabilitation and repair projects.

### 5.1 DESIGN CRITERIA FOR INSTALLATION, REHABILITATION AND REPAIR

The City's Sanitary Sewer Design Standards, Standard Plans, and Standard Specifications for sewer mainlines, structures and appurtenances like maintenance holes, lift stations, and service laterals (lower laterals) are administered by the Engineering Division of the City Public Works Department.

#### 5.1.1 General

The City has established standards for both new construction and renewal and replacement work associated with the collection system. These standards are periodically reviewed and updated by the Engineering Division and were last updated in 2009, and are currently being revised. The City's latest version of its *Sanitary Sewer Design Standards* is included in Appendix H.

A publication termed Standard Specifications for Public Works Construction are updated every three years by a group of public works design professionals and are used as the basic standards for the City. These standards are commonly referred to in the industry as the "Green Book". The Engineering Division has made revisions to certain sections of the Green Book to meet the needs of the City's system, and these *City Adaptations to Green Book* are included as Appendix I.

Complete versions of the City's Standard Specifications and Standard Plans are located on the City's website at <http://cityofdavis.org/home/showdocument?id=1283> and <http://public-works.cityofdavis.org/Media/PublicWorks/Documents/PDF/PW/Engineering/2009UpdatedStandardPlans.pdf>, respectively. The referenced City standards provide for both new construction and rehabilitation and repair of all main lines sewers, trunk sewers, manholes and other collection system appurtenances.

#### 5.1.2 Lift Stations

The City requires that all new or rehabilitated lift stations be designed by an appropriately experienced engineer and approved by the City Engineer before construction and acceptance by the City Council for maintenance. The stations are required to have fully automatic control systems, connection to the City SCADA system, and redundant pumping capability.

### 5.1.3 City Sewer System – Authorized Pipe Materials

The authorized materials that are currently accepted in the City Sewer System are shown in Table 12. The standards are currently being revised to include polyvinylchloride pipe (PVC) as the new standard.

| <b>Table 12. Acceptable Pipe Materials for New Gravity Sewers</b> |   |   |
|---|---|---|
| <b>Material</b>   | <b>Designation</b>  | <b>Standard</b>   |
| VCP   | Use for all mains and service laterals  | Sanitary Sewer Design Standards, in accordance with Green Book specifications |
| DIP   | Use in areas with shallow cover   | Sanitary Sewer Design Standards, in accordance with Green Book specifications |
| Other Materials   | Other materials (like Acrylonitrile-Butadiene-Styrene) may be used if given special approval by the City Engineer | Green Book specifications, allowed by Sanitary Sewer Design Standards         |

### 5.1.4 Private Sewer Systems and Private Laterals

All private sewer systems and private sewer laterals are required to be design, installed, inspected and accepted per the Green Book and the City Adaptations to the Green Book. Private sewer laterals must also conform to the requirements of the California Plumbing Code.

## 5.2 INSPECTION AND TESTING CRITERIA

The City’s Wastewater Collection System inspection and testing Criteria are based on the Green Book. The City’s inspection and testing criteria are:

### 5.2.1 New and Rehabilitated Gravity Sewers

a. Design

Sewer system designs must be prepared by an appropriately experienced engineer for the review and approval by the City Building Division.

b. Inspection during Construction

All new gravity sewers will be periodically inspected during construction to ensure that the sewer is constructed using the specified materials and methods. Specific approvals will be required by the inspector prior to backfilling the trench, prior to paving, and prior to acceptance by the City. The contractor will be required to provide survey controls so that the inspector can verify line and grade (slope). Unusual conditions and special features will be recorded for future reference.

c. Leakage

All new gravity sewers will be tested to verify that they have been properly constructed. Sewers between 8 and 16 inches in diameter will be tested following Standard Specifications for Public Works Construction; Section 306-1.4.4 Air Pressure Test. Gravity sewers that fail the test shall be repaired and retested until they pass.

d. CCTV Inspection

All new gravity sewers will be inspected using a CCTV to verify that the pipe is free from defects/damage, that the joints have been correctly constructed, and that the sewer is free from sags that will cause future operational problems. Gravity sewers shall be cleaned prior to inspection and shall be flushed with water so that sags can be readily identified. Defects shall be recorded following the City standards. Sags that exceed one inch in depth shall be repaired.

### 5.2.2 New and Rehabilitated Manholes

a. Inspection during Construction

All work for new and rehabilitated manholes to be performed in compliance with “Section 5 System Rehabilitation” of the current edition of the Green Book. For manhole lining and inspection, refer to “500-2 MANHOLE AND STRUCTURE REHABILITATION”.

b. Leakage

All new manholes will be vacuum tested to verify that the joints, connections, and frame/cover are tight. The vacuum test will follow ASTM C1244. The test will be conducted at a 10-inch Hg vacuum. The vacuum loss shall be less than one-inch Hg for the time determined by the inspector or engineer.

Manholes that fail the vacuum test shall be repaired using materials and methods approved by the City Engineer and retested until they pass.

### 5.2.3 New and Rehabilitated Lift Stations

a. Inspection during Construction

All new and rehabilitated lift stations will be periodically inspected during construction to ensure that they are constructed using the specified materials and methods. Unusual conditions and special features will be recorded for future reference.

b. Functional Test

All systems in new and rehabilitated lift stations will be tested to ensure they function as intended.

c. Performance Test

All new and rehabilitated lift stations will be required to pass an extended performance test to ensure that they are capable of reliably meeting the design performance for a period of continuous operation without failure or alarms. The results of these performance tests will be recorded for use as a basis for evaluating future lift station performance.

### 5.3 REFERENCES

The following information was used to develop this Element:

- Davis Public Works Revised Design Standards *September 19, 1991*.
- Standard Specifications for Public Works Construction (*2015 Greenbook*).

**SWRCB Waste Discharge Requirement:**

Each Enrollee shall develop and implement an Overflow Emergency Response Plan (OERP) that identifies measures to protect public health and the environment. At a minimum, this plan must include the following:

- a. Proper notification procedures so that the primary responders and regulatory agencies are informed of all SSOs in a timely manner;
- b. A program to ensure an appropriate response to all overflows;
- c. Procedures to ensure prompt notification to appropriate regulatory agencies and other potentially affected entities (e.g. health agencies, Regional Water Boards, water suppliers, etc.) of all SSOs that potentially affect public health or reach the waters of the State in accordance with the Monitoring and Reporting Program (MRP). All SSOs shall be reported in accordance with this MRP, the California Water Code, other State Law, and other applicable Regional Water Board WDRs or NPDES permit requirements. The SSMP should identify the officials who will receive immediate notification;
- d. Procedures to ensure that appropriate staff and contractor personnel are aware of and follow the Emergency Response Plan and are appropriately trained;
- e. Procedures to address emergency operations, such as traffic and crowd control and other necessary response activities; and
- f. A program to ensure that all reasonable steps are taken to contain and prevent the discharge of untreated and partially treated wastewater to waters of the United States and to minimize or correct any adverse impact on the environment resulting from the SSOs, including such accelerated or additional monitoring as may be necessary to determine the nature and impact of the discharge.

The OERP is included in full in Appendix L. This section includes the purpose, policy, and goals of the OERP.

**6.1 PURPOSE**

The purpose of the City of Davis's OERP is to support an orderly and effective response to SSOs. The OERP provides guidelines for City personnel to follow in responding to, cleaning up, and reporting SSOs that may occur within the City's service area. This OERP satisfies the SWRCB Statewide GWDR, which require wastewater collection agencies to have an OERP.

**6.2 POLICY**

The City's employees are required to report all wastewater overflows resulting from the City-owned/maintained sanitary sewer system found and to take the appropriate action to secure the wastewater overflow area, properly report to the appropriate regulatory agencies, relieve the cause of the overflow, and ensure that the affected area is cleaned as soon as possible to minimize health hazards to the public and protect the environment. The City's goal is to respond to sewer system overflows as soon as possible following notification. The City will follow reporting



procedures in regards to sewer spills as set forth by the Central Valley Regional Water Quality Control Board (RWQCB) and the SWRCB.

### 6.3 GOALS

The City's goals with respect to responding to SSOs are:

- Work safely;
- Respond quickly to minimize the volume of the SSO;
- Eliminate the cause of the SSO;
- Prevent sewage system overflows or leaks from entering the storm drain system or receiving waters to the maximum extent practicable;
- Contain the spilled wastewater to the extent feasible;
- Minimize public contact with the spilled wastewater;
- Mitigate the impact of the SSO;
- Meet the regulatory reporting requirements;
- Evaluate the causes of failure related to certain SSOs; and
- Revise response procedures resulting from the debrief and failure analysis of SSOs.

**SWRCB Waste Discharge Requirement:**

Each Enrollee shall evaluate its service area to determine whether a FOG control program is needed. If an Enrollee determines that a FOG program is not needed, the Enrollee must provide justification for why it is not needed. If FOG is found to be a problem, the Enrollee must prepare and implement a FOG source control program to reduce the amount of these substances discharged to the sanitary sewer system. This plan shall include the following as appropriate:

- a. An implementation plan and schedule for a public education outreach program that promotes proper disposal of FOG;
- b. A plan and schedule for the disposal of FOG generated within the sanitary sewer system service area. This may include a list of acceptable disposal facilities and/or additional facilities needed to adequately dispose of FOG generated within a sanitary sewer system service area;
- c. The legal authority to prohibit discharges to the system and identify measures to prevent SSOs and blockages caused by FOG;
- d. Requirements to install grease removal devices (such as traps or interceptors), design standards for the removal devices, maintenance requirements, BMP requirements, record keeping and reporting requirements;
- e. Authority to inspect grease producing facilities, enforcement authorities, and whether the Enrollee has sufficient staff to inspect and enforce the FOG ordinance;
- f. An identification of sanitary sewer system sections subject to FOG blockages and establishment of a cleaning maintenance schedule for each section; and
- g. Development and implementation of source control measures for all sources of FOG discharged to the sanitary sewer system for each section identified in (f) above.

**7.1 NATURE AND EXTENT OF FOG PROBLEM**

Table 13 lists the total number of FOG-related mainline SSOs from 2011 through 2015. As of May 2016, the City has experienced only two (2) FOG-related SSOs in main lines and only 2 in laterals in the past five years.

| <b>Table 13. Historical FOG-Related SSOs in Main Lines</b> |                           |
|--|---------------------------|
| <b>Calendar Year</b>                                       | <b>SSOs caused by FOG</b> |
| 2015   | -                         |
| 2014   | 1                         |
| 2013   | -                         |
| 2012   | -                         |
| 2011   | 1                         |

## 7.2 FOG SOURCE CONTROL PROGRAM - REVIEWS & INSPECTIONS

The City has a fully functioning FOG Program that identifies, monitors, and regulates sources of FOG so that SSOs that result from FOG are minimized. The primary purpose of the program is to reduce the occurrence of FOG-related mainline SSOs in the service area, although the current level of FOG-related SSOs is extremely low. The City focuses on FSEs to effectively prevent or reduce FOG-related mainline SSOs. The City currently maintains a list of about 162 FSEs, 31 of which are conditionally exempt, that are regularly inspected and monitored for compliance with the City Municipal Code, in particular Article 33.03.165 in Chapter 33 regarding requirements grease interceptors for FSEs. The City modified its Sewers and Sewage Disposal Code in 2013 to require FOG pretreatment in the form of grease traps and/or interceptors for FSEs and the current Code is posted on the City's website at: <http://qcode.us/codes/davis/>.

The City's FOG Source Control Program is intended to work in conjunction with the City's PM program to prevent FOG-related SSOs. It remains an essential component in meeting and maintaining its projected SSO reduction performance goals. The City's program includes FSE reviews and inspections, enforcement of the City's Municipal Code sections regarding FOG, and is managed by City staff, an Environmental Program Specialist.

The elements of the City's FOG Source Control Program include:

- Requirement for the installation of grease removal devices (GRDs);
- Requirement for proper operation and maintenance of GRDs;
- Verification of grease handling and disposal practices;
- FSE reviews and inspections;
- Public Education and Outreach; and
- Enforcement.

The Environmental Program Specialist typically conducts two reviews of FSEs per year. The reviews are done on a random basis. A review letter is transmitted to the facility or discharger prior to the review with information regarding the review, such as the date and time of the review and what is to be inspected or reviewed. The results of the review are then sent to the FSE in a letter, generally within two weeks following the review.

Public education and outreach remains an integral element of the FOG Program. Outreach is provided to FSE staff and management during routine reviews and inspections, as well as through multiple items of correspondence throughout the year. The City has written communication with FSEs at least four times per year in addition to the two site visits or reviews. A copy of the FSE outreach materials is provided in Appendix J.

The Specialist checks GRDs as part of the review process and works with FSE staffs in an on-going, collaborative relationship to stress the importance the City places on review and inspection items. Frequent contact and meetings with FSEs and their manager/owners has helped to decrease the need for corrective actions in the last five years. Reviews of FSEs requiring

corrective actions decreased from approximately 80 percent in 2013 to about 25 percent in the latter half of 2014.

City staff offers assistance to managers and owners of FSEs with demonstrations and education to FSE employees regarding the cleaning and maintenance of under counter GRDs. City staff also offers FSEs a consultation and inspection of a review of grease interceptors to determine the need for their cleaning. If City staff is asked to check a facility's GRD, there is no charge for this service by City staff and no regulatory liability if it's determined there is a need for immediate cleaning.

Any item that needs corrective action as a result of the City's review and inspections are summarized in the review follow-up letter to FSEs. Such a letter lists the review findings and corrections to be made. The City may send a specific enforcement letter with milestone dates if the conditions discovered at the review warrant such an action.

The City is considering updating the collection system ordinance to include fines for failure to maintain FOG removal devices, and is also considering initiating an annual compliance review for FSEs to encourage regular cleaning and compliance. Currently, the City is evaluating the effectiveness of the program through the number of enforcement actions required.

### 7.3 RESPONSE TO GWDR REQUIREMENTS

***Requirement (a): An implementation plan and schedule for a public education outreach program should promote proper disposal of FOG.***

Response: The City is currently managing its FOG with a FOG Source Control Program and an aggressive and focused PM program (sewer cleaning). The "downtown" area has a large concentration of FSEs and this entire area is cleaned quarterly by field crews. The very infrequent blockages and SSOs that are caused by FOG from residential sources, two in the last five years, are extremely minor.

***Requirement (b): A plan and schedule for the disposal of FOG generated within the sanitary sewer system service area. This may include a list of acceptable disposal facilities and/or additional facilities needed to adequately dispose of FOG generated within a sanitary sewer system service area.***

Response: There are disposal sites available close to Davis (Yolo County) and in Oakland (EBMUD) that are used by the commercial grease haulers working within the City's service area.

***Requirement (c): The legal authority to prohibit discharges to the system and identify measures to prevent SSOs and blockages caused by FOG.***

Response: The City's Municipal Code provides the legal basis and authority (see Element 3) for the City's FOG Control Program; specifically, Article 33.03.165 in Chapter 33 regarding requirements grease interceptors for FSEs. The City modified its Sewers and Sewage Disposal Code in 2013 to require FOG pretreatment in the form of grease traps and/or interceptors for FSEs and the current Code is posted on the City's website at: <http://qcode.us/codes/davis/>.

***Requirement (d): Requirements to install grease removal devices (such as traps or interceptors), design standards for the grease removal devices, maintenance requirements, BMP requirements, record keeping and reporting requirements.***

Response: The City's FOG Control Program described above in (c) currently meets these requirements (Chapter 33 of the Municipal Code, Sewers and Sewage Disposal). Staff also works with FSEs to convey standards, BMPs, maintenance and recordkeeping requirements.

***Requirement (e): Authority to inspect grease producing facilities, enforcement authorities, and determination of whether the collection system agency has sufficient staff to inspect and enforce the FOG ordinance.***

Response: The City's FOG Control Program involves regular inspections or reviews by the City's Environmental Program Specialist and enforcement by the City (based upon review findings). The authority to inspect or review is granted by the Municipal Code, as previously stated.

***Requirement (f) and (g): Requirement (f) is an identification of sewer system sections subject to FOG blockages and the establishment of a cleaning maintenance schedule for each section, and Requirement (g) is the development and implementation of source control measures, for all sources of FOG discharged to the sewer system.***

Response: The City's FOG Source Control Program and its PM program are currently focused on problematic grease dischargers and "high frequency" maintenance or cleaning in the area with the greatest concentration of FSEs. The City adapts to FOG-related problems and issues, if and when they occur.

**SWRCB Waste Discharge Requirement:**

The Enrollee shall prepare and implement a CIP that will provide hydraulic capacity of key sanitary sewer system elements for dry weather peak flow conditions, as well as the appropriate design storm or wet weather event. At a minimum, the CIP must include:

- a. **Evaluation:** Actions needed to evaluate those portions of the sanitary sewer system that are experiencing or contributing to an SSO discharge caused by hydraulic deficiency. The evaluation must provide estimates of peak flows (including flows from SSOs that escape from the system) associated with conditions similar to those causing overflow events, estimates of the capacity of key system components, hydraulic deficiencies (including components of the system with limiting capacity) and the major sources that contribute to the peak flows associated with overflow events;
- b. **Design Criteria:** Where design criteria do not exist or are deficient, undertake the evaluation identified in (a) above to establish appropriate design criteria; and
- c. **Capacity Enhancement Measures:** The steps needed to establish a short- and long-term CIP to address identified hydraulic deficiencies, including prioritization, alternatives analysis, and schedules. The CIP may include increases in pipe size, I/I reduction programs, increases and redundancy in pumping capacity, and storage facilities. The CIP shall include an implementation schedule and shall identify sources of funding.

**Schedule:** The Enrollee shall develop a schedule of completion dates for all portions of the capital improvement program developed in (a)-(c) above. This schedule shall be reviewed and updated consistent with the SSMP review and update requirements as described in Section D.14.

## 8.1 SYSTEM CAPACITY EVALUATION

The City contracted with NEXGEN Utility Management to complete a Sewer Capacity Evaluation and Assurance Plan (SECAP) dated April 2009. This study created a spreadsheet based hydraulic model that determined that capacity in the Davis collection system was generally adequate. The study found that the City's main trunk sewers only had adequate capacity to pass peak wet weather flows. This study did not validate through flow monitoring the flows used in the SECAP. The hydraulic model utilized the 2010 Davis General Plan for the determination of both short and long term flow requirements. The SECAP reviewed and relied upon historical SSOs from November 2007 to March 2009 documented in CIWQS.

The hydraulic analysis utilized the average dry weather flow based upon land use types in the City General Plan within designated areas of the City. The model used traditional flow generation standards developed from historical City records applied to 17 separate discharge areas identified in the model.



The SECAP was considered a phase I SECAP in that the results were not field verified through system flow monitoring. The City has now contracted with West Yost Associates to conduct flow monitoring during the 2016 storm season. These results will be used to develop a dynamic hydraulic model of the entire collection system replacing the old spreadsheet model. The new model will be calibrated against the results of the flow monitoring; various capacity alternatives run through the model and capacity deficiencies defined from the model. All findings from the new evaluation will be appended to the existing SECAP, which is described in the June 2015 Collection System Master Plan Evaluation Report, in the next twelve months.

## 8.2 DESIGN CRITERIA

The capacity-related design criteria, including base wastewater flow and peaking factors, are included in Element V: Design and Performance Provisions. These criteria were determined from historical rainfall records and resulted in the definition of a design storm based upon a December 31, 2005 rainfall event. The SECAP also documented and established formal design criteria for evaluating the sewer capacities. This study also defined a rainfall intensity-duration-frequency curve for the Davis hydraulic model.

## 8.3 CAPACITY ENHANCEMENT MEASURES - CAPITAL IMPROVEMENT PROGRAM (CIP)

The City prepares an annual list of capital improvement projects that includes projects to address recently identified wastewater collection system capacity issues. Engineering staff prioritize and select the projects to be included on the annual list.

The April 2009 SECAP did identify priorities for capacity enhancements to the trunk sewer system based upon risks of failure and consequences of failure. The City has been working toward enhancing these trunk lines through its annual capital improvement program. The City has prepared a ten-year sewer capital improvement program includes estimated expenditures up to \$16,800,000 for pipeline rehabilitation and pump station upgrades.

As a part of the Sewer Strategic Plan, the current CIP program was revised to include a new 10-year list of capacity-related CIP projects. Alternatives are analyzed and schedules are established during the design process and updated annual with the revisions to the City's CIP for all City infrastructure.

The current schedule for the City's capacity enhancement projects does not include any capacity related improvement projects. However, this list will be revised, as necessary, based upon future condition assessments and maintenance results from the field crews.

The City's CIP budget and schedule is included as Appendix K.

#### **8.4 REFERENCES**

The following information was used to develop this Element:

- System Evaluation and Capacity Assurance Plan – Needs Assessment, April 2009, NEXGEN Utility Management.
- Lift Station Assessment and Inventory Report, February 2015, Hydrosience.
- Wastewater Collection System Evaluation Report, June 2015, West Yost Associates.

**SWRCB Waste Discharge Requirement:**

The Enrollee shall:

- a. Maintain relevant information that can be used to establish and prioritize appropriate SSMP activities;
- b. Monitor the implementation and, where appropriate, measure the effectiveness of each element of the SSMP;
- c. Assess the success of the PM program;
- d. Update program elements, as appropriate, based on monitoring or performance evaluations; and
- e. Identify and illustrate SSO trends, including: frequency, location, and volume.

## 9.1 PERFORMANCE MEASURES

The indicators that the City will use to measure the performance of its wastewater collection system and the effectiveness of its SSMP are:

- SSOs: Total number, Number for each cause (roots, grease debris, pipe failure, capacity, lift station failures, and other), SSO rate (#/100 miles/year);
- Portion of sewage recovered compared to total volume spilled;
- Volume of spilled sewage discharged to Waters of the State; and
- All indicators for service (lower) laterals, separately from gravity mains, force mains, and lift stations.

In addition, the City will consider other performance measures with metrics in the future for issues such as work order costs, CCTV assessment work, and rehabilitation and replacement of sewers.

## 9.2 BASELINE PERFORMANCE

The City has performance measures in place and it will evaluate its performance annually following the end of the calendar year. The historical, or baseline, performance is shown separately for gravity mains/lift stations/force mains and lower laterals.

### 9.2.1 Mains, Lift Stations, and Force Mains

The baseline performance and SSO trends for gravity mains, lift stations, and force mains is shown in Table 14 and Figure 5. The results indicate a trend of reduction in SSOs to only one main line SSO per year in both 2014 and 2015, and no lift station or force main SSOs since 2011.

| Calendar Year | Gravity Main Sewer SSOs | Lift Station SSOs | Force Main SSOs |
|---------------|-------------------------|-------------------|-----------------|
| 2011          | 3                       | 1                 | 0               |
| 2012          | 3                       | 0                 | 0               |
| 2013          | 3                       | 0                 | 0               |
| 2014          | 1                       | 0                 | 0               |
| 2015          | 1                       | 0                 | 0               |

**Figure 5. Trend in Number of Gravity Sewer, Lift Station, and Force Main SSOs**

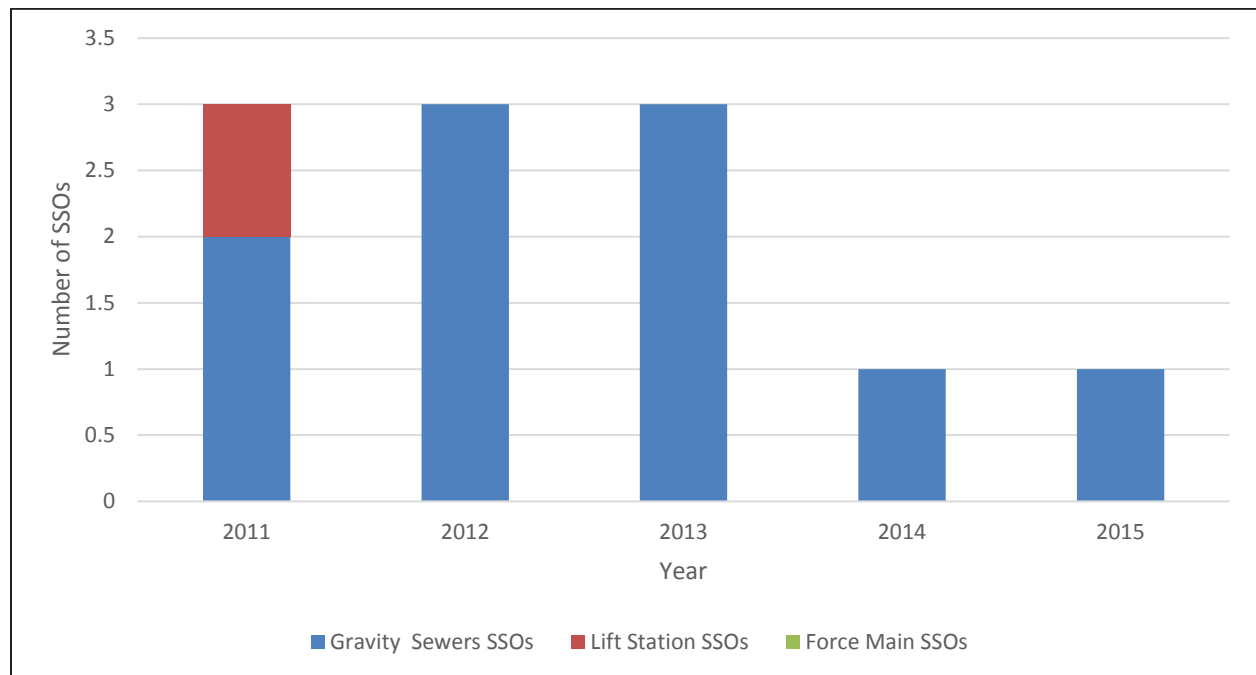

**Figure 6. Trend in Number of Lateral and Mainline SSOs**

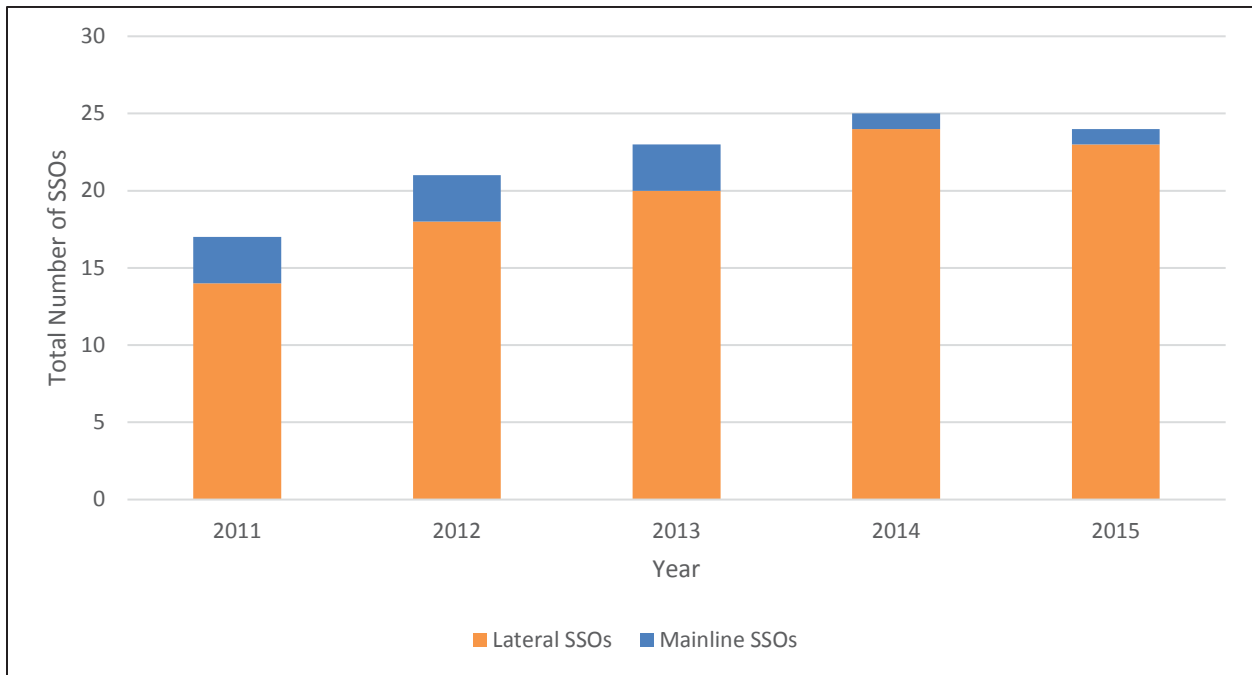

**Table 15. Mainline SSOs by Cause**

| CY   | Roots | Debris | Grease | Infiltration | Vandalism/Other | Pipe Failure | PS Failure | Total |
|------|-------|--------|--------|--------------|-----------------|--------------|------------|-------|
| 2011 | 0     | 1      | 1      | 0            | 0               | 0            | 1          | 3     |
| 2012 | 1     | 1      | 0      | 0            | 1               | 0            | 0          | 3     |
| 2013 | 0     | 3      | 0      | 0            | 0               | 0            | 0          | 3     |
| 2014 | 0     | 0      | 1      | 0            | 0               | 0            | 0          | 1     |
| 2015 | 0     | 1      | 0      | 0            | 0               | 0            | 0          | 1     |

**Figure 7. Trend in Gravity Sewer, Lift Station and Force Main SSOs by Cause**

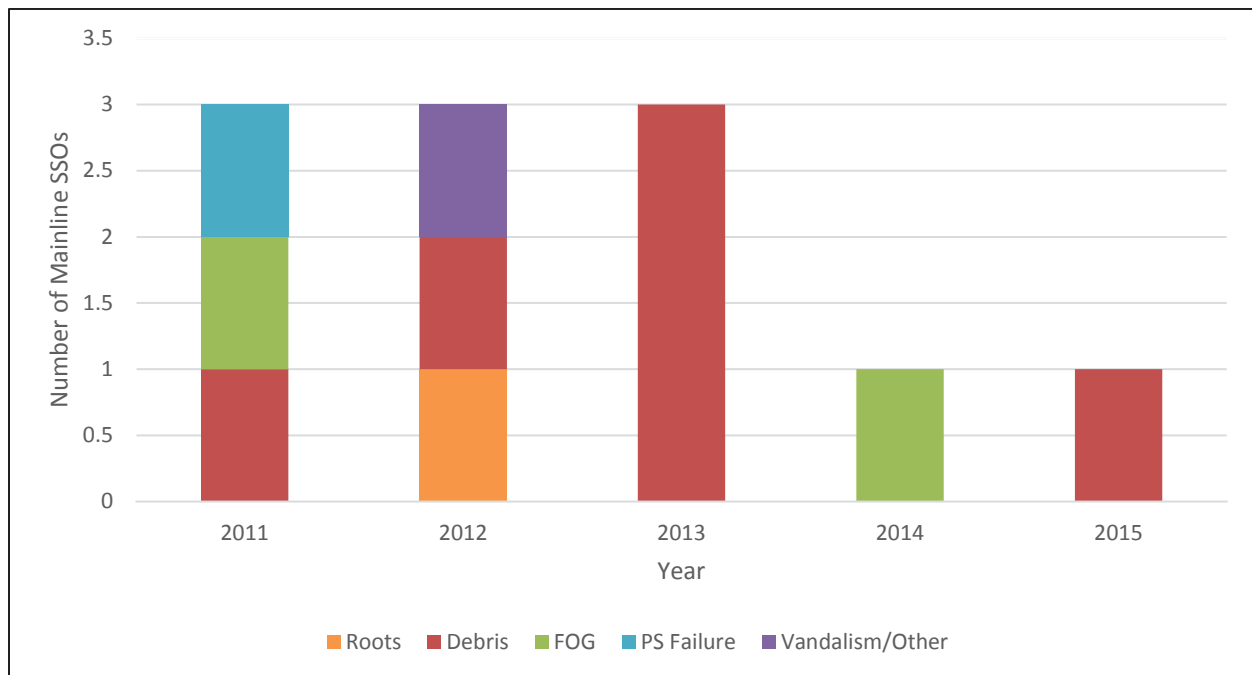
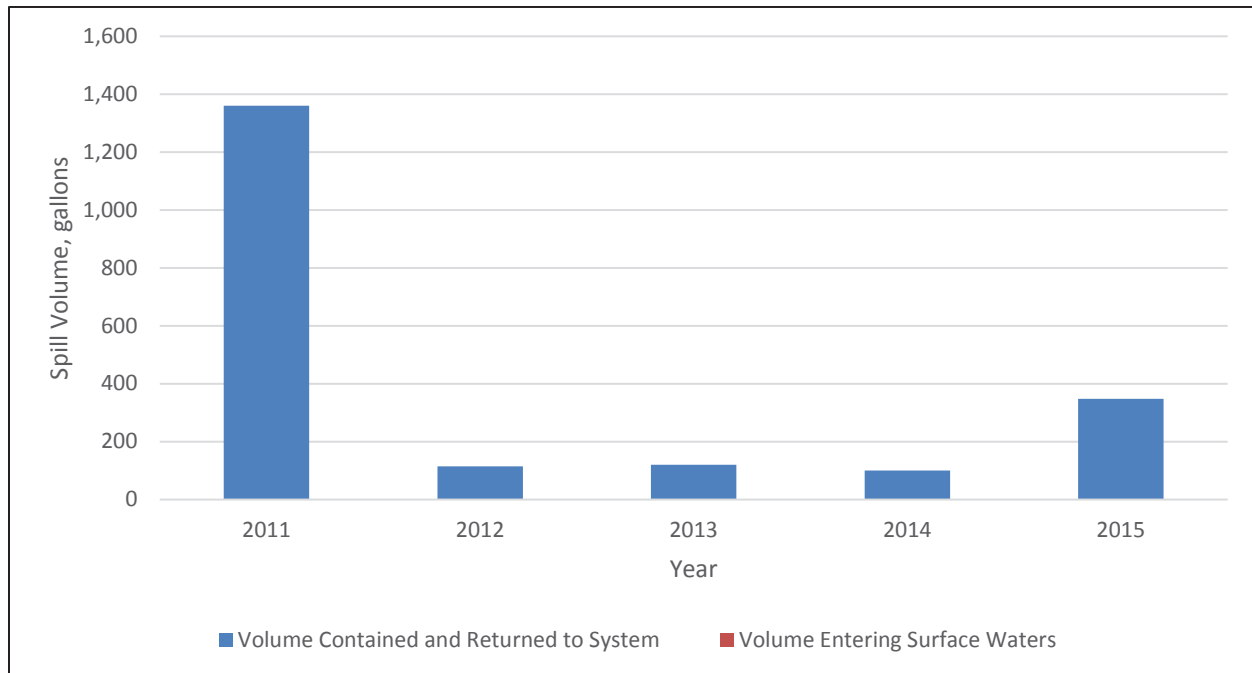

**Table 16. Mainline SSO Volumes**

| CY   | Total Volume, gallons | Portion Contained and Returned to Sewers, percent | Total Volume Entering Surface Waters, gallons |
|------|-----------------------|---|---|
| 2011 | 1484                  | 93  | 0   |
| 2012 | 115                   | 100   | 0   |
| 2013 | 120                   | 100   | 0   |
| 2014 | 100                   | 100   | 0   |
| 2015 | 348                   | 100   | 0   |



**Figure 8. Trend in Volume of Mainline SSOs**



The above Table 15, Figure 6, and Figure 7 show the data and trends in causes of Mainline, Lift Station and Force Main SSOs for the last five years (2011-2015). Table 16 and Figure 8 indicate the Mainline SSO volumes and trends for the five-year period. Similar to SSO data and trends, the numbers are very low and the trend is a reduction in SSO volume.

### 9.2.2 Public Laterals (Service or Lower Laterals)

The baseline performance and trends in public laterals SSOs is shown in Table 17 and the causes of these SSOs is shown in Figure 9. Lateral SSOs remained fairly consistent in 2013-2015, and higher than in 2011 and 2012. Figure 9 shows the majority of lateral SSOs are caused by roots.

| CY   | Roots | Debris | Grease | Infiltration | Vandalism | Pipe Failure | Other – Maint. | Total |
|------|-------|--------|--------|--------------|-----------|--------------|----------------|-------|
| 2011 | 4     | 7      | 1      | 0            | 0         | 0            | 2              | 14    |
| 2012 | 16    | 2      | 0      | 0            | 0         | 0            | 0              | 18    |
| 2013 | 12    | 8      | 0      | 0            | 0         | 0            | 0              | 20    |
| 2014 | 9     | 5      | 1      | 0            | 1         | 2            | 6              | 24    |
| 2015 | 14    | 4      | 0      | 0            | 0         | 1            | 4              | 23    |

**Figure 9. Trend in Cause of Public Sewer Lateral SSOs**

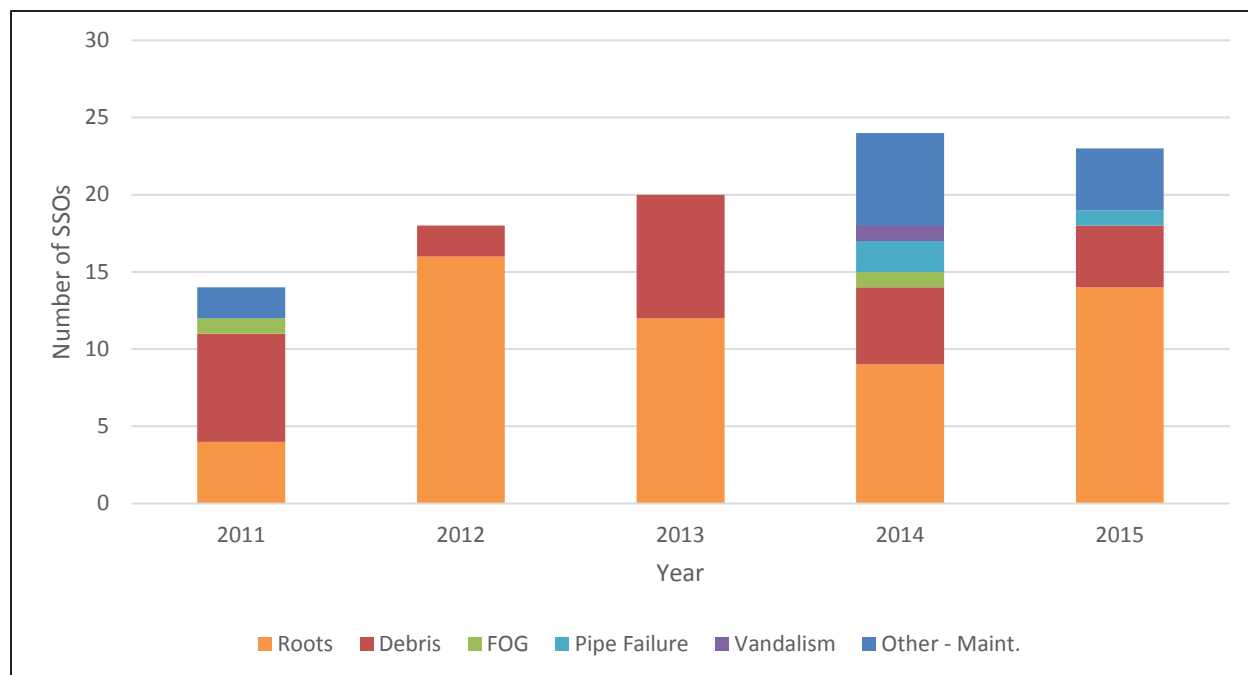
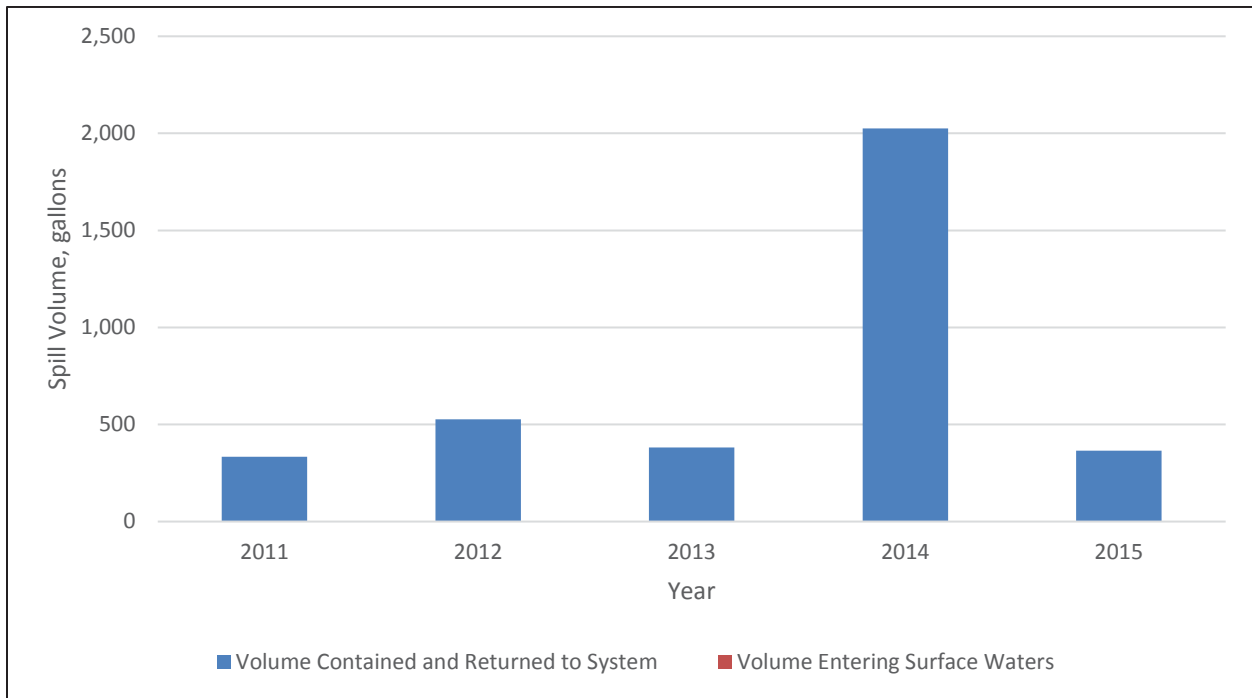

Table 18 below shows the SSO volumes of lateral SSOs in the period of 2011-2015. The volumes are very small, less than 1,000 gallons per year in all years except for 2014, and in four of these years over 99 percent of the SSO volume was captures and returned to the City collection system. Figure 10 shows this trend. Figure 11 displays the trend in both mainline and lateral SSOs, in the number of SSOs per 100 miles of system per year. As noted above, the mainline rate is very low, 0.6 to 1.8, and the lateral rate ranges from 4.7 to 8. While this lateral rate is higher, the SSO volume from these lateral SSOs is very small.

| CY   | Total Volume, gallons | Portion Contained and Returned to Sewers, percent | Total Volume Entering Surface Waters, gallons |
|------|-----------------------|---|---|
| 2011 | 339                   | 99  | 0   |
| 2012 | 531                   | 99  | 0   |
| 2013 | 382                   | 100   | 0   |
| 2014 | 2025                  | 100   | 0   |
| 2015 | 425                   | 86  | 0   |

**Figure 10. Trend in Volume of Public Sewer Lateral SSOs**



**Figure 11. Trend in Rate of SSOs per 100 miles per Year**

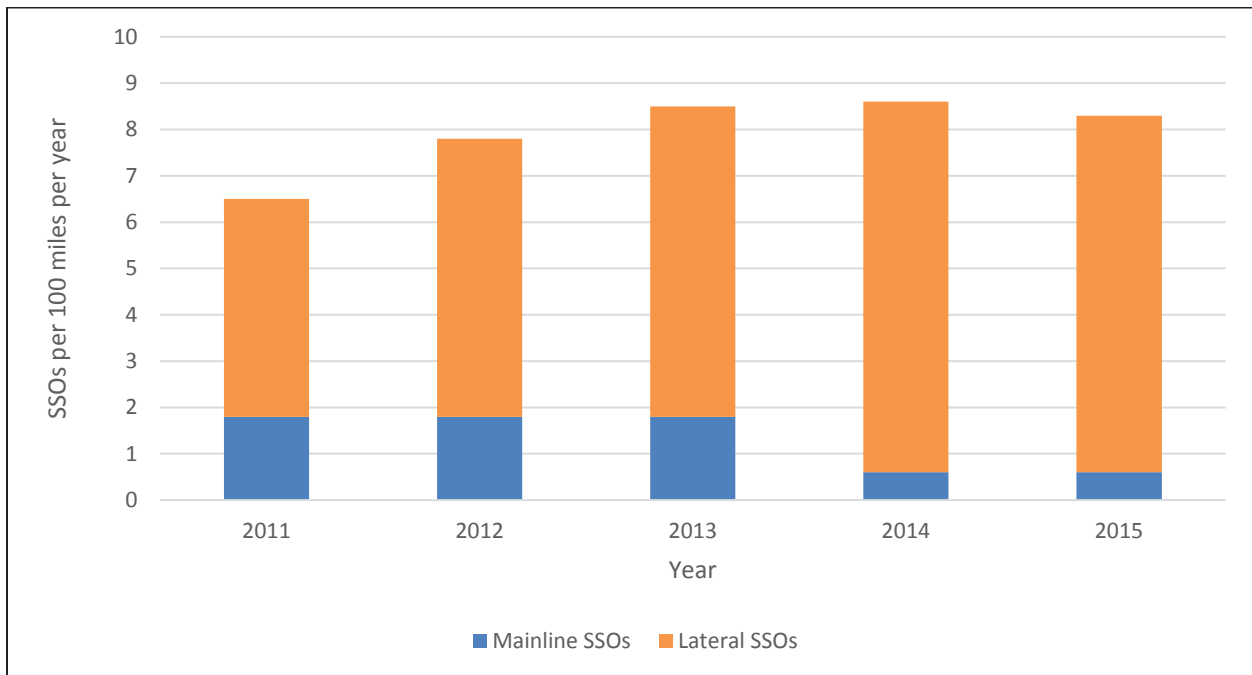

### **9.3 PERFORMANCE MONITORING AND PROGRAM CHANGES**

The City will evaluate the performance of its wastewater collection system at least annually using the performance measures identified in this Element. The City will update the data and analysis at the time of the evaluation and will place the annual performance report in Appendix D of the SSMP.

The City may use other performance measures in its evaluation. The City will prioritize its actions and initiate changes to this SSMP, its operations and maintenance practices, and any related programs based on the results of the evaluation. This will be done as part of the annual self-audit (see Element X).

### **9.4 REFERENCES**

The following information was used to develop this Element:

- The data used in this section were taken from City records and CIWQS SSO data as of May 31, 2016.

**SWRCB Waste Discharge Requirement:**

As part of the SSMP, the Enrollee shall conduct periodic internal audits, appropriate to the size of the system and the number of SSOs. At a minimum, these audits must occur every two years and a report must be prepared and kept on file. This audit shall focus on evaluating the effectiveness of the SSMP and the Enrollee's compliance with the SSMP requirements identified in this subsection (D.13), including identification of any deficiencies in the SSMP and steps to correct them.

**10.1 AUDITS**

The City will audit its implementation and compliance with the provisions of this SSMP every two years as required by the WDR. The audit will be conducted and completed no later than every two years following original adoption by the City Council. Previous City SSMP Audits are now included in Appendix D. The audit will be conducted by a team consisting of City Staff selected from the Public Works Department. The audit team may include members from other departments of the City, outside agencies, or contractors. It is also recommended that an audit of its SSO files to assure that the files are complete, contain all required records as stated in the MRP and that the files contain no extraneous or conflicting documents that are not adequately reviewed and explanations provided be conduct.

The SSMP Audit Report Form, included in Appendix D, is used to guide the audit process and includes the GWDR requirements for each SSMP element. The results of the audit, including the identification of any deficiencies and the steps taken or planned to correct deficiencies will be included in an Audit Report. Upon completion of the audit, the City will include a copy of the Final Audit Report in Appendix D of this SSMP. Modifications and changes to the SSMP will be identified and tracked in Appendix C.

The audit may contain information about successes in implementing the most recent version of the SSMP, and identify revisions that are needed for a more effective program. Information collected can be used in preparing the audit. Tables and figures or charts can be used to summarize information about these indicators. An explanation of the SSMP development, and accomplishments in improving the sewer system, should be included in the audit, including:

- How the sewer system agency implemented SSMP elements since the last audit;
- The effectiveness of implementing SSMP elements;
- A description of the additions and improvements made to the sanitary sewer collection system in the past reporting year; and
- A description of the additions and improvements planned for the upcoming reporting year with an estimated schedule for implementation.



## 10.2 SSMP UPDATES

The City will recertify its SSMP five years from the original date of City Council adoption and approval or when substantial changes are made in the SSMP. The City will determine the need to update its SSMP more frequently based on the results of the audits and the performance of its wastewater collection system using information from the Monitoring and Measuring Program in Element IX. In the event that the City decides that an update is warranted, the process to complete the update will be identified, assigned to certain staff and include a schedule for completion. The City will complete the update and take the revisions to the City Council no later one year of identifying the need for an update.

**SWRCB Waste Discharge Requirement:**

The Enrollee shall communicate on a regular basis with the public on the development, implementation, and performance of its SSMP. The communication system shall provide the public the opportunity to provide input to the Enrollee as the program is developed and implemented.

The Enrollee shall also create a plan of communication with systems that are tributary and/or satellite to the Enrollee's sanitary sewer system.

**11.1 COMMUNICATION DURING SSMP DEVELOPMENT AND IMPLEMENTATION**

The City maintains a website (<http://cityofdavis.org/>) to inform the public about City activities. The City's website is an effective communication channel for providing alerts and news to the public. The website provides important announcements, public hearing notices, links to agendas and minutes for City Council meetings, and other key information for City residents. The City will publish the most up-to-date SSMP on the Public Works Department page of the City website. The current SSMP was first certified by the City Council during a public City Council meeting on August 21, 2012.

The City, at least annually following the close of the fiscal year, communicates with the City Council at a public meeting that allows for input from the public with regard to the implementation and performance results of the collection system operations. Many of the performance metrics are included in the annual budget document, which is posted on the City's website.

Other information provided upon request to interested parties includes: brochures and materials regarding collection system operations and maintenance and contact information and/or opportunities for input into the implementation process. The City will also have brochures and information on collection system programs at various department counters in the City as well as available on the City website.

**11.2 COMMUNICATION WITH SATELLITE WASTEWATER COLLECTION SYSTEMS**

The City has two extraterritorial services areas that discharge to the City collection system, Teichert Construction Corporation Yard and the Royal Oaks Mobile Home Park. The City will work to develop regular communications with these two service areas to assure that these systems do not produce any sewage or debris that could be detrimental to the City collection system operations or the treatment plant.

**11.3 REFERENCES**

The following information was used to develop this Element: SWRCB Order No. 2006-003-DWQ.

## APPENDIX A

---

### Responsible Officials in Water Quality Chain of Communication

## Appendix A. Responsible Officials in Water Quality Chain of Communication

| Element    | Element Name                                      | Position Title                             | Responsible City Official | Phone        | Email                      |
|------------|---|--|---------------------------|--------------|----------------------------|
|            | Introduction                                      | Senior WWTP Supervisor                     | John Alexander            | 530-747-8283 | JAlexander@cityofdavis.org |
| I          | Goals   |  |                           |              |                            |
| II         | Organization                                      |  |                           |              |                            |
| III        | Legal Authority                                   |  |                           |              |                            |
| IV         | Operations and Maintenance Program                | Senior Public Works Collections Supervisor | Allen Turner              | 530-681-7872 | aturner@cityofdavis.org    |
| V          | Design and Performance Provisions                 | Associate Civil Engineer                   | Terry Jue                 | 530-757-5686 | tjue@cityofdavis.org       |
| VI         | Overflow Emergency Response Plan                  | Senior Public Works Collections Supervisor | Allen Turner              | 530-681-7872 | aturner@cityofdavis.org    |
| VII        | Fats, Oils and Grease (FOG) Control Program       | Environmental Inspector                    | Kirk Freeman              | 530-757-5686 | kfreeman@cityofdavis.org   |
| VIII       | System Evaluation and Capacity Assurance Plan     | Associate Civil Engineer                   | Terry Jue                 | 530-757-5686 | tjue@cityofdavis.org       |
| IX         | Monitoring, Measurement and Program Modifications | Senior WWTP Supervisor                     | John Alexander            | 530-747-8283 | JAlexander@cityofdavis.org |
| X          | Program Audits                                    | Assistant Public Works Director            | Stan Gryczko              | 530-757-5686 | sgryczko@cityofdavis.org   |
| XI         | Communications Program                            | Senior WWTP Supervisor                     | John Alexander            | 530-747-8283 | JAlexander@cityofdavis.org |
| Appendix A | SSMP Adoption Documents                           |  |                           |              |                            |
| Appendix B | SSMP Change Log                                   |  |                           |              |                            |
| Appendix C | SSMP Audit Reports                                |  |                           |              |                            |

## APPENDIX B

---

Sewer System Management Plan Council Adoption Documents

MINUTES OF THE DAVIS CITY COUNCIL  
Meeting of August 21, 2012

The City Council of the City of Davis met in regular session beginning at 5:30 p.m. in the Community Chambers, 23 Russell Boulevard, Davis, California. The meeting was called to order by Mayor Krovoza.

Roll Call: Councilmembers Present: Lucas Frerichs, Joe Krovoza, Brett Lee, Rochelle Swanson, Dan Wolk

Councilmembers Absent: None

Other Officers Present: City Manager Steve Pinkerton, City Attorney Harriet Steiner, City Clerk Zoe Mirabile

Approval of Agenda J. Krovoza: Overview of the Beyond Platinum Bicycle Action Plan will be heard before Water Advisory Committee Recommendations regarding the Water Supply Project and Contract to Raise the Regional Water Treatment Facility.

D. Wolk moved, seconded by R. Swanson, to approve the agenda as amended. Motion passed unanimously.

Closed Session Council convened a Closed Session pursuant to Government Code §54954.5 to discuss the following:

1. Conference with Labor Negotiators.

Agency Designated Representatives: City Manager Steve Pinkerton; City Attorney Harriet Steiner; Human Resources Administrator Melissa Chaney; Tim Yeung, Renne Sloan Holtzman Sakai, LLP.

Employee Groups/Organizations (under discussion): Davis City Employees Association; Davis Police Officers Association; Department Heads; Executive and General Management; Firefighters Local 3494; Fire Management; Police Management; Program, Administrative and Support Employees Association.

2. Conference with Real Property Negotiators.

Properties: APN Nos. 33-290-88 and 70-311-04

Agency Negotiators: City Attorney Harriet Steiner, Property Management Coordinator Anne Brunette

Negotiating Parties: Mark Mendenhall

Under Negotiation: Price and terms of payment

3. Conference with Legal Counsel—Existing Litigation: Davis Depot At Grade Crossing Application Proceeding; CPUC Case No. A.11-08-14.

4. Conference with Legal Counsel-Anticipated Litigation: Initiation of litigation pursuant to Government Code Section 54956.9 (c): 1 case.



City Council returned to open session at 6:52 p.m. with no reportable action.

Brief Communi-  
cations

City Manager Steve Pinkerton: August 22 will be high traffic day, first day of school for K-12 graders.

R. Swanson: City will be hosting a symposium with I-Gate partners; consider innovative plans for transportation.

B. Lee: Attended Yolo County Housing Association meeting.

J. Krovoza: Sister City Sang-Ju, Korea, will be hosting conference on Water September 14-15; invited sister city Mayors to attend; will be speaking at conference regarding water and energy connections.

Public Com-  
ments

- Alan Pryor: Request item regarding plastic bags be pulled from the consent calendar and sent back to Natural Resources Commission for deliberation.
- Trish Stanionis, Yolo Family Service Agency: Will be screening children from 0-5 years, will return to Council in a few months with status report, screen early to get a head start on developmental needs.
- Mike Gualco, Downey Brand, counsel for Verizon Wireless: Request consent calendar item – Cell Tower Lease County Road 105-be removed for Council discussion; tower owned by client and will remain so after lease; interested in maintaining service at site.
- Matt Carrow, American Towers: Request removal of consent calendar – Cell Tower Lee County Road 105; request lease extension to end of month; significant revenue sharing opportunity.

Consent Calen-  
dar

Agreement with First 5 Yolo Children and Families Commission for Fiscal Year 2012-2013

Approved Resolution No. 12-126 - Authorizing the City Manager to Enter Into an Agreement with First 5 Yolo Children and Families Commission, Related to the Administration of Childcare Quality Improvement Programs.

Sewer System Management Plan

Approved Resolution No. 12-127 - Adopting the Sewer System Management Plan for the City of Davis.

Subrecipient Agreement for the Pass-Through of Federal Funds to UC Davis for Highway Bridge Replacement and Rehabilitation Program (HBRRP)

Approved Resolution No. 12-128 – Resolution Authorizing the City Manager to Execute Subrecipient Agreement with the University of California-Davis for Use of Federal Highway Bridge Replacement and Rehabilitation Funds

Legal Services Contract with McKenna Long & Aldridge, LLP for Legal Support During the Preparation of the Design-Build Procurement Documents for the Wastewater Improvements Project (CIP No. 8219)

Approved Resolution No. 12-129 - Authorizing the City Manager to Execute a

Consultant Agreement with Mckenna Long & Aldridge for Legal Services for the Wastewater Treatment Plant Improvements Project, CIP No. 8219

Fiscal Year 2012-13 Chrome 6 Pilot Project

1. Approved Resolution No. 12-130 - Authorizing the City Manager to Execute Professional Services Agreement with Kennedy/Jenks Consultants for the Fy12-13 Chrome 6 Pilot Project
2. Approved Resolution No. 12-131 - Resolution Authorizing the City Manager to Execute The Grant Funding Agreement with the State Water Resources Control Board (SWRCB) to Fund a Portion of the City of Davis Chrome 6 Pilot Study
3. Approved Resolution No. 12-132 - Authorizing the City Manager to Execute Cost Sharing Partner Agreements with Sacramento Groundwater Authority (SGA) and Water Resources Association of Yolo County (WRA) to Fund a Portion of the Chrome 6 Pilot Study
4. Approved Budget Adjustment #20 (\$139,358) – appropriating grant revenue and cost sharing funding contributions from project partners

Community Park Play Area Renovation

1. Approved implementation of the play equipment replacement scope
2. Approved Budget Adjustment #22 (\$45,000) – allocating Park Impact Fees

School Crossing Guard Contract

1. Approved Resolution No. 12-133 - Authorizing the City Of Davis to Enter into a Contract with American Guard Services, Inc., for Operating the School Crossing Guard Program
2. Approved Resolution No. 12-134 - Authorizing the City Of Davis to Enter into a Memoranda Of Agreement with Davis Joint Unified School District to Share Expenses of the School Crossing Guard Program

Cool Cities Challenge - Letter of Intent

Approved Resolution No. 12-135 - Supporting the Cool Cities Challenge and Authorizing the City Manager to Sign a Non-Binding Letter of Intent to Be Considered as a Candidate City to Participate in the Challenge

Conservation Easement Defense – Easement Baseline Updates

Approved Budget Adjustment #24 (\$17,890) – allocating Open Space Program Funds

Plans, Specifications and Estimate for Wastewater Rehabilitation and Replacement Project, CIP No. 8219, Project 82001

Approved the plans and specifications, and authorized bid advertisement

Reject Bids for the Central Park Restroom Project, CIP No. 8211

Approved Resolution No. 12-136 - Rejecting All Bids for Central Park Restroom, CIP No. 8211

League of California Cities - 2012 Annual Conference Resolution Packet  
Reviewed the five resolutions introduced for consideration at the League of California Cities 2012 Annual Conference, and directed its appointed voting delegates to represent the position of the City of Davis as follows:

- 1a. NEUTRAL: Resolution 3 – Desert Protection Act
- 1b. SUPPORT: Resolution 1 – Public Safety-Fines & Forfeitures;  
Resolution 2 – Public Safety-Internet Crimes Against Children;  
Resolution 5 – Public Safety-Emergency Management Mission
- 1c. OPPOSE: Resolution 4 – Global Warming
  - 1. Waive City Council policy requiring two readings of resolutions establishing a City position on matters not directly related to City affairs.
  - 2. Authorize the City’s voting delegate(s) to represent the City of Davis on any additional “petitioned” resolutions that may be presented to the General Assembly for consideration.

Treasurer’s Report for the Quarter Ended June 30, 2012  
Accepted the report

Yolo County Historical Society Annual Report  
Informational

Commission Minutes (informational only):

- 1. Bicycle Advisory Commission Meetings of June 4 and July 2, and Joint Meeting with the Safety and Parking Advisory Commission of May 3, 2012
- 2. Human Relations Commission Meeting of June 28, 2012

Informational

D. Wolk moved, second by L. Frerichs, to approve consent calendar as listed above. Motion passed unanimously.

Removed from  
Consent

Item removed by B. Lee.

Amend Consultant Contract  
Amount for Additional Services – Fifth Street Corridor Improvements, CIP No. 8138

By consensus, Council directed staff to return with further options on pedestrian crossing safety that could be incorporated into phase 1.

B. Lee moved, seconded by L. Frerichs, to approve the following:

- 1. Resolution No. 12-137 - Authorizing the City Manager to Execute Amendment No. 1 to Consultant Agreement with KD Anderson & Associates for Additional Services for the Fifth Street Corridor Improvements Project, CIP No. 8138
- 2. Budget Adjustment #23 (\$25,000) – allocating Roadway Impact Fee and RDA Successor Agency Funds

Motion passed unanimously.

E Street  
“Parklet” Proposal

Removed from consent by R. Swanson.

R. Swanson: Highlight project for community; thanked developer

R. Swanson moved, seconded by D. Wolk, to approve Resolution No. 12-138 - Authorizing Installation of a Parklet at 105 E Street. Motion passed unanimously.

Council Direction Regarding Single Use Carry-out Bag Ordinance Policy

Item removed by D. Wolk.

D. Wolk: Suggest tabling discussion at Council level and task Natural Resources Commission to draft priorities and return to Council for check in.

Utilities Manager Jacques De Bra: After state regulations are settled, staff will return for Council further direction.

J. Krovoza moved, seconded by R. Swanson, to direct staff to return to Council with proposed Natural Resources Commission Plastic Bag Ban Ordinance, to include discussion of overall priorities of the Commission and alternative approaches that would result in reduction in plastic bag use. Motion passed unanimously.

Successor Agency Consent Calendar

R. Swanson moved, seconded by L. Frerichs, to approve Resolution No. 12-139 - Approving Recognized Obligation Payment Schedule for the Period Ending June 30, 2013. Motion passed unanimously.

Public Hearing: Planning Application #12-33: Mitigated Negative Declaration #1-12, Preliminary Planned Development/ Rezone #2-12: 2750 Cowell Boulevard

R. Swanson Recused herself from item due to a conflict of interest stemming from real property within 500 feet of site, and left the room.

Planner Cathy Camacho: Overview of project, primary difference in zoning is adding new use of commercial recreation.

Mayor Krovoza opened the public hearing, and after no comments, closed the public hearing.

D. Wolk moved, seconded by L. Frerichs, as follows:

1. Determine that Mitigated Negative Declaration #1-12 adequately addresses the environmental impacts associated with the proposed project
2. Introduce Ordinance Amending Chapter 40 of the Davis Municipal Code, Rezoning the Parcel Located at 2750 Cowell Boulevard (APN #69-390-95), Consisting of Approximately 3.37 Acres, from Planned Development #12-87, Industrial Research Subarea, to Planned Development (PD) #2-12
3. Approve PA #12-33; Rezone #2-12, based on the findings contained in the body of the Ordinance in support of the proposed action

Motion passed by the following vote:

AYES: Frerichs, Lee, Wolk, Krovoza

NOES: None

ABSENT: Swanson

Overview of  
Draft Outline -  
Beyond Platinum  
- Bicycle Action  
Plan

Active Transportation Coordinator Dave Kemp: Presented updated 2009 bicycle plan and draft objectives.

Public comment:

- Elaine Roberts-Musser: Support plan and integration into transportation element; safety is of paramount concern, seniors as pedestrians don't know how to handle bicycles; support addressing bike theft.

R. Swanson: Request additional check-ins with Council

D. Kemp: Suggest twice yearly; final draft plan scheduled to return to Council in January.

By consensus, Council approved the public input process and authorized staff to continue the plan process.

City Council recessed at 8:16 p.m. and reconvened at 8:30 p.m.

Water Advisory  
Committee Rec-  
ommendations -  
Water Supply  
Project

Principal Civil Engineer Dianna Jensen: Summarized Water Advisory Committee (WAC) timeline and recommendation.

Public comments:

- Matt Williams: Wording in staff recommendation dropped the word "equally" in 2A: both cities share equally in cost of pipelines to convey the treated water to the city limits of each city, etc. Good compromise; encourage 2x2 meetings with West Sacramento to be publicly noticed and provide for public attendance.
- Elaine Roberts-Musser, WAC Chair: Long and successful process; will be attending meetings to provide answers if needed.

B. Lee moved, seconded by D. Wolk, as follows

1. The City Council agrees with the main ideas of the Water Advisory Committee (WAC) recommendation and agrees to the following:

1A. Negotiate via the Joint Powers Authority (JPA) to have the cost sharing of the Woodland/Davis joint water project better reflect the proposed water split percentages. The proposed water split is 18 mgd for Woodland, 12 mgd for Davis. These percentages are 60%/40%. The current cost sharing of the treatment facility is based upon a roughly 56% Woodland share, 44% Davis share.

1B. Negotiate via the JPA a shared piping cost for the cost of the pipelines from the treatment plant to each of the cities. Currently, Davis pays for its own cost of piping from the treatment facility to the city limits and Woodland pays for its own costs as well.

2A. Negotiate with the City of West Sacramento to determine if they are willing to lower the connection costs for jointing their system.

2B. Negotiate with the City of West Sacramento to determine if they are

willing to enter into a long-term water supply agreement for 12 mgd for a time period in the neighborhood of 30 years with long-term renewal options.

2C. Negotiate with the City of West Sacramento to create a pathway for future system upgrades.

2. Whichever project/approach is chosen, Davis shall seriously investigate and consider the use of deferred financing options to reduce the initial rate impacts for our water users.
3. It is understood that the WAC has not yet investigated the pros and cons of the proposed design-build-operate (DBO) approach, and the City Council looks forward to receiving the WAC's advice on this subject.

R. Swanson proposed a friendly amendment to include the following: That over the next 60 days, the City Council pursue negotiations with Woodland and West Sacramento to implement the recommendations of the WAC. Accepted.

R. Swanson proposed a friendly amendment for City Council to pursue negotiations with Cities and Councilmembers, instead of Joint Powers Authority (JPA). Accepted.

J. Krovoza moved substitute motion, seconded by L. Frerichs, as follows:

1. The Davis City Council formally receives the recommendations of the Water Advisory Committee from its August 16 meeting.
2. Over the next 60 days, the City Council will negotiate with Woodland and West Sacramento to pursue the recommendations of the WAC. As soon as these negotiations are completed with either or both parties, or advanced as far as feasible, Council will share its progress with the WAC to seek the WAC's acceptance or further direction.
3. During this period, the WAC will continue to prepare recommendations to the City Council on the Woodland Davis Clean Water Agency's proposed DBO bidding process, and on the appropriate rate structure for future city water supply pricing.

Motion passed unanimously.

J. Krovoza moved, seconded by L. Frerichs, to authorize J. Krovoza and B. Lee to negotiate with West Sacramento, and B. Lee and R. Swanson to negotiate with Woodland as needed.

R. Swanson moved substitute motion, seconded by B. Lee, to authorize J. Krovoza and B. Lee to negotiate with West Sacramento, and R. Swanson and D. Wolk to negotiate with Woodland. Motion passed unanimously.

Construction  
Contract to Raise  
the RWTF Site

R. Swanson moved, second by D. Wolk, to approve Resolution No. 12-140 – City of Davis to Pay the City of Woodland for the Incremental Additional Cost to Place Fill Necessary to Raise the Regional Water Treatment Facility (RWTF)



Site Out of the Floodplain. Motion passed unanimously.

Removed from  
Consent Calendar:

Item removed by R. Swanson.

Cell Tower  
Lease on County  
Road 105

Property Management Coordinator Anne Brunette: City acquired property, which includes cell tower lease agreement that is set to expire August 31, 2012; staff began lease negotiations 2 years ago. Summarized recent offers. Staff recommends 2 potential options:

- Direct City Manager and staff, along with possible Council Subcommittee, to negotiate terms of an agreement with American Tower Corp. to be resolved by August 31, 2012, consistent with terms described: request a shorter initial time frame (5-year term) to allow for additional discussions for a replacement tower that could potentially provide more carriers and generate more revenue for the City; request money up front alongside a completely signed agreement with Verizon; and address minor issues such as revenue sharing consistent with lease at John Jones Road site.
- ComSites West as alternative, using existing lease at John Jones Road as template for lease at this site.

Public Comments:

- Mike Carrows, American Tower: Reasonable to discuss further; in regards to extending tower and potential additional carriers—staff would like American Tower to pursue AT&T and T-Mobile; highly interested in saving site.
- Mike Gualco, Downey Brand: Thanked Council and staff for patience; would like to maintain presence at site.

R. Swanson moved, seconded by L. Frerichs, to allow American Tower to negotiate with staff and legal counsel; if agreement is not reached along with executed documents and upfront payment by August 31, 2012, then contract will be terminated and staff will pursue negotiations with ComSites West. Motion passed unanimously.

Item Submitted  
by Councilmembers  
(Krovoza/  
Wolk):

J. Krovoza: Possible mechanisms for bond financing and raising revenue

S. Pinkerton:

- SB 1156 – Sustainable Communities Investment Authority; California Redevelopment Association and League of California Cities (LOCC) do not support in current form
- AB 2144 – Infrastructure and Revitalization Financing Districts is being watched
- SB 214 - Infrastructure Financing Districts, LOCC supports

Consider Support  
for Pending Bills  
Related to Post-  
Redevelopment  
Agency City  
Funding  
Mechanisms:  
SB1156,  
AB2144, and  
SB214

J. Krovoza moved, seconded by D. Wolk, that Council support in concept SB 214 and AB 2144 in their efforts to create infrastructure financing districts in California. Motion passed unanimously.

J. Krovoza: Request staff prepare a letter of support to Senator's office and

Speaker's office for Mayor to sign.

Long Range  
Calendar

S. Pinkerton:

- Fifth Street Update and Plastic Bag Ordinance will be agendaized next month
- September 11—public hearing on sanitation rates
- September 25—Cannery Park project
- October 9—Energy assessment report
- October 23—Investment policy
- November: Community pool feasibility study

D. Wolk: Request staff agendaize September 11 remembrance Proclamation.  
Council consensus.

R. Swanson: Fire station morning memorial activities; suggest incorporate  
Council efforts.

R. Swanson: September 3—labor day race and Sister City Inuyama, Japan visit.

Adjournment

Meeting was adjourned at 10:15 p.m.

Zoe S. Mirabile, CMC  
City Clerk

## APPENDIX C

---

### Sewer System Management Plan Change Log

### Log of SSMP Changes

| Date      | SSMP Element   | Description of Change/Revision Made   | Person Authorizing Change                                  |
|-----------|--|---|--|
| 3/21/2017 | Introduction   | Added description of regulatory requirements and system inventory tables; updated system description and system maps  | Wastewater Division Manager                                |
| 3/21/2017 | Element I: Goals   | Added WDR for clarity; updated goals to reflect existing SSMP priorities  | Wastewater Division Manager                                |
| 3/21/2017 | Element II: Organization                                       | Added WDR for clarity; updated organizational chart and roles and responsibilities to reflect staffing and role changes; assigned SSMP responsibilities; added SSO Reporting flow chart for clarity   | Wastewater Division Manager                                |
| 3/21/2017 | Element III: Legal Authority                                   | Added WDR for clarity; added references to Municipal Code for clarity; added description of agreements with satellite agencies  | Wastewater Division Manager                                |
| 3/21/2017 | Element IV: Operations and Maintenance Program                 | Added WDR for clarity; updated collection system mapping, preventative operation and maintenance, training, and equipment and replacement parts descriptions to reflect current procedures; added description of rehabilitation and replacement program | Wastewater Division Manager                                |
| 3/21/2017 | Element V: Design and Performance Provisions                   | Added WDR for clarity; added descriptions of design criteria and inspection and testing criteria for easy reference   | Wastewater Division Manager                                |
| 3/21/2017 | Element VI: Overflow Emergency Response Plan                   | Added WDR for clarity; updated OERP to reflect current response and reporting procedures and to meet revised MRP requirements   | Wastewater Division Manager, Senior Collections Supervisor |
| 3/21/2017 | Element VII: Fats, Oils, and Grease (FOG) Control Program      | Added WDR for clarity; updated FOG control program activities to reflect current procedures; added description of compliance with GWDR for clarity  | Wastewater Division Manager                                |
| 3/21/2017 | Element VIII: System Evaluation and Capacity Assurance Plan    | Added WDR for clarity; added descriptions of SECAP assessment and capital improvement program for easy reference  | Wastewater Division Manager                                |
| 3/21/2017 | Element IX: Monitoring, Measurement, and Program Modifications | Added WDR for clarity; developed additional performance measures that align with revised goals; updated spill charts and tables with recent SSO records   | Wastewater Division Manager                                |

**Log of SSMP Changes**

| Date      | SSMP Element                      | Description of Change/Revision Made   | Person Authorizing Change                                    |
|-----------|-----------------------------------|---|--|
| 3/21/2017 | Element X: SSMP Program Audits    | Added WDR for clarity; minor text revisions and addition of SSMP Audit form to facilitate audit process; added description of SSMP update requirement | Wastewater Division Manager                                  |
| 3/21/2017 | Element XI: Communication Program | Added WDR for clarity; updated communication program description to reflect current procedures  | Wastewater Division Manager, Assistant Public Works Director |
|           |                                   |   |  |
|           |                                   |   |  |
|           |                                   |   |  |
|           |                                   |   |  |
|           |                                   |   |  |
|           |                                   |   |  |
|           |                                   |   |  |

## APPENDIX D

---

### Sewer System Management Plan Audit Reports



## SSMP Audit Checklist

The purpose of the SSMP Audit is to evaluate the effectiveness of the City of Davis SSMP and to identify any needed for improvement.

Directions: Please check YES or NO for each question. If NO is answered for any question, describe the updates/changes needed and the timeline to complete those changes.

|  |     |    |
|--|-----|----|
|  | YES | NO |
|--|-----|----|

### ELEMENT I: GOALS

|    |  |                          |                          |
|----|--|--------------------------|--------------------------|
| A. | Are the goals stated in the SSMP still appropriate and accurate? | <input type="checkbox"/> | <input type="checkbox"/> |
|----|--|--------------------------|--------------------------|

Discussion:

### ELEMENT II: ORGANIZATION

|    |  |                          |                          |
|----|--|--------------------------|--------------------------|
| A. | Is the List of City Staff Responsible for SSMP current?  | <input type="checkbox"/> | <input type="checkbox"/> |
| B. | Is the Sanitary Sewer Overflow Responder List current?   | <input type="checkbox"/> | <input type="checkbox"/> |
| C. | Is Figure 2-1 of the SSMP, the City Organization Chart, current?   | <input type="checkbox"/> | <input type="checkbox"/> |
| D. | Are the position descriptions an accurate description of current staff responsibilities?                         | <input type="checkbox"/> | <input type="checkbox"/> |
| E. | Is Table 2-2 in the Chain of Communication for Reporting and Responding to SSOs section accurate and up-to-date? | <input type="checkbox"/> | <input type="checkbox"/> |

Discussion:

### ELEMENT III: LEGAL AUTHORITY

Does the SSMP contain current references to the City of Davis Municipal Code documenting the City's legal authority to:

|    |  |                          |                          |
|----|--|--------------------------|--------------------------|
| A. | Prevent illicit discharges?  | <input type="checkbox"/> | <input type="checkbox"/> |
| B. | Require proper design and construction of sewers and connections   | <input type="checkbox"/> | <input type="checkbox"/> |
| C. | Ensure access for maintenance, inspection, or repairs for portions of the lateral owned or maintained by the City? | <input type="checkbox"/> | <input type="checkbox"/> |
| D. | Limit discharges of fats, oils and grease?   | <input type="checkbox"/> | <input type="checkbox"/> |
| E. | Enforce any violation of its sewer ordinances?   | <input type="checkbox"/> | <input type="checkbox"/> |
| F. | Were any changes or modifications made in the past year to City Sewer Ordinances, Regulations or standards?        | <input type="checkbox"/> | <input type="checkbox"/> |

Discussion:

## SSMP Audit Checklist

### ELEMENT IV: OPERATIONS AND MAINTENANCE

#### Collection System Maps

|    |  |                          |                          |
|----|--|--------------------------|--------------------------|
| A. | Does the SSMP reference the current process and procedures for maintaining the City's wastewater collection system maps?   | <input type="checkbox"/> | <input type="checkbox"/> |
| B. | Are the City's wastewater collection system maps complete, current and sufficiently detailed?  | <input type="checkbox"/> | <input type="checkbox"/> |
| C. | Are storm drainage facilities identified on the collection system maps? If not, are SSO responders able to determine locations of storm drainage inlets and pipes for possible discharge to waters of the state? | <input type="checkbox"/> | <input type="checkbox"/> |

#### Prioritized Preventive Maintenance

|    |  |                          |                          |
|----|--|--------------------------|--------------------------|
| D. | Does the SSMP describe current preventive maintenance activities and the system for prioritizing the cleaning of sewers?                                     | <input type="checkbox"/> | <input type="checkbox"/> |
| E. | Based upon information in the Annual SSO Report, are the City's preventive maintenance activities sufficient and effective in minimizing SSOs and blockages? | <input type="checkbox"/> | <input type="checkbox"/> |

#### Scheduled Inspections and Condition Assessments

|    |  |                          |                          |
|----|--|--------------------------|--------------------------|
| F. | Is there an ongoing condition assessment program sufficient to develop a capital improvement plan addressing the proper management and protection of infrastructure assets? Are the current components of this program documented in the SSMP? | <input type="checkbox"/> | <input type="checkbox"/> |
|----|--|--------------------------|--------------------------|

#### Contingency Equipment and Replacement Inventory

|    |   |                          |                          |
|----|---|--------------------------|--------------------------|
| G. | Does the SSMP list the major equipment currently used in the operation and maintenance of the collection system and documents the procedures of inventory management? | <input type="checkbox"/> | <input type="checkbox"/> |
| H. | Are contingency and replacement parts sufficient to respond to emergencies and properly conduct regular maintenance?  | <input type="checkbox"/> | <input type="checkbox"/> |

#### Training

|    |  |                          |                          |
|----|--|--------------------------|--------------------------|
| I. | Does the SSMP document current training expectations and programs? | <input type="checkbox"/> | <input type="checkbox"/> |
|----|--|--------------------------|--------------------------|

#### Outreach to Plumbers and Building Contractors

|    |   |                          |                          |
|----|---|--------------------------|--------------------------|
| J. | Does the SSMP document currently outreach efforts to plumbers and building contractors? | <input type="checkbox"/> | <input type="checkbox"/> |
|----|---|--------------------------|--------------------------|

## SSMP Audit Checklist

Discussion:

### ELEMENT V: DESIGN AND PERFORMANCE STANDARDS

|    |  |                          |                          |
|----|--|--------------------------|--------------------------|
| A. | Does the SSMP reference current design and construction standards for the installation for new sanitary sewer systems, lift stations and other appurtenances and for the rehabilitation and repair of existing sanitary sewer systems? | <input type="checkbox"/> | <input type="checkbox"/> |
| B. | Does the SSMP document current procedures and standards for inspecting and testing the installation of new sewers, pumps, and other appurtenances and the rehabilitation and repair of existing sewer lines?                           | <input type="checkbox"/> | <input type="checkbox"/> |

Discussion:

### ELEMENT VI: OVERFLOW AND EMERGENCY RESPONSE PLAN

|    |  |                          |                          |
|----|--|--------------------------|--------------------------|
| A. | Does the City's Sanitary Sewer Overflow Emergency Response Plan establish procedures for the emergency response, notification, and reporting of SSOs?  | <input type="checkbox"/> | <input type="checkbox"/> |
| B. | Is City staff and contractor personnel appropriately trained on the procedures of the Sanitary Sewer Overflow Emergency Response Plan?   | <input type="checkbox"/> | <input type="checkbox"/> |
| C. | Considering SSO performance data, is the Sanitary Sewer Overflow Emergency Response Plan effective in handling SSOs in order to safeguard public health and the environment?   | <input type="checkbox"/> | <input type="checkbox"/> |
| D. | Are all SSO and claims reporting forms current or do they require revisions or additions?  | <input type="checkbox"/> | <input type="checkbox"/> |
| E. | Does all SSO event recordkeeping meet the SSS GWDR requirements? Are all SSO event files complete and certified in the CIWQS system?   | <input type="checkbox"/> | <input type="checkbox"/> |
| F. | Is all information in the CIWQS system current and correct? Have periodic reviews of the data been made during the year to assure compliance with SSS GWDR? Have all Technical Report and Water Quality Sampling requirements been certified and uploaded to the CIWQS data management system? | <input type="checkbox"/> | <input type="checkbox"/> |

### SSMP Audit Checklist

|    |  |                          |                          |
|----|--|--------------------------|--------------------------|
| G. | Was required training on SSMP and OERP completed and documented? Were field exercises with field staff on SSO volume estimation conducted and documented?  | <input type="checkbox"/> | <input type="checkbox"/> |
| H. | Did all public improvement plans and specifications that could impact collection system operations include requirements for OERP training or were contractor OERP programs at least as stringent as the City OERP? Were regular items included in project meeting agendas to discuss emergency response procedures and communications? | <input type="checkbox"/> | <input type="checkbox"/> |

Discussion:

#### ELEMENT VII: FATS, OILS AND GREASE (FOG) CONTROL PROGRAM

|    |  |                          |                          |
|----|--|--------------------------|--------------------------|
| A. | Does the FOG Control Program include efforts to educate the public on proper handling and disposal of FOG?   | <input type="checkbox"/> | <input type="checkbox"/> |
| B. | Does the FOG Control Program identify sections of the collection system subject to FOG blockages, establish a cleaning schedule and address source control measures to minimize these blockages? | <input type="checkbox"/> | <input type="checkbox"/> |
| C. | Are requirements for grease removal devices, best management practices (BMP), record keeping and reporting established in the City's FOG Control Program?  | <input type="checkbox"/> | <input type="checkbox"/> |
| D. | Does the City have sufficient legal authority to implement and enforce the FOG Control Program?  | <input type="checkbox"/> | <input type="checkbox"/> |
| E. | Is the current FOG program effective in minimizing blockages of sewer lines resulting from discharges of FOG to the system   | <input type="checkbox"/> | <input type="checkbox"/> |

Discussion:

**SSMP Audit Checklist**

**ELEMENT VIII: SYSTEM EVALUATION AND CAPACITY ASSURANCE PLAN**

|    |   |                          |                          |
|----|---|--------------------------|--------------------------|
| A. | Does the Sanitary Sewer Strategic Plan evaluate hydraulic deficiencies in the system, establish sufficient design criteria and recommend both short and long term capacity enhancement and improvement projects?  | <input type="checkbox"/> | <input type="checkbox"/> |
| B. | Does the City's Capital Improvement Program (CIP) establish a schedule of approximate completion dates for both short and long-term capacity improvements and is the schedule reviewed and updated to reflect current budgetary capabilities and activity accomplishment? | <input type="checkbox"/> | <input type="checkbox"/> |

Discussion:

**ELEMENT IX: MONITORING, MEASUREMENT, AND PROGRAM MODIFICATIONS**

|    |   |                          |                          |
|----|---|--------------------------|--------------------------|
| A. | Does the SSMP accurately portray the methods of tracking and reporting selected performance indicators?         | <input type="checkbox"/> | <input type="checkbox"/> |
| B. | Is the City able to sufficiently evaluate the effectiveness of the SSMP elements based on relevant information? | <input type="checkbox"/> | <input type="checkbox"/> |
| C. | Have all graphs and tables of performance results been updated with the most current results?                   | <input type="checkbox"/> | <input type="checkbox"/> |

Discussion:

**ELEMENT X: SSMP AUDITS**

|    |   |                          |                          |
|----|---|--------------------------|--------------------------|
| A. | Will the SSMP Audit be completed, reviewed and filed in Appendix D? | <input type="checkbox"/> | <input type="checkbox"/> |
|----|---|--------------------------|--------------------------|

Discussion:

## SSMP Audit Checklist

### ELEMENT XI: COMMUNICATION PROGRAM

|    |   |                          |                          |
|----|---|--------------------------|--------------------------|
| A. | Does the City effectively communicate with the public, satellite agencies and other service areas about the implementation of the SSMP and continue to address any feedback?    | <input type="checkbox"/> | <input type="checkbox"/> |
| B. | Did City staff conduct and document meetings with satellite collection systems? Are all agreements with satellite systems current or are changes necessary to these agreements? | <input type="checkbox"/> | <input type="checkbox"/> |

Discussion:

### Change Log

|    |   |                          |                          |
|----|---|--------------------------|--------------------------|
| A. | Is the SSMP Change Log, current and up to date? | <input type="checkbox"/> | <input type="checkbox"/> |
|----|---|--------------------------|--------------------------|

Discussion:

Audit Team: \_\_\_\_\_ Date: \_\_\_\_\_

Prepared By: \_\_\_\_\_ Date: \_\_\_\_\_

Reviewed By: \_\_\_\_\_ Date: \_\_\_\_\_



## APPENDIX E

---

### Lift Station Condition Assessment Checklist

| <b>Lift Station Condition Assessment Checklist</b>                      |  |
|---|--|
| <b>Inspection Information</b>   |  |
| Inspection date   |  |
| Inspection participants   |  |
| Facility name   |  |
| Facility address  |  |
| Comments  |  |
| <b>Background Information (Prior 12 Months)</b>                         |  |
| SSOs  |  |
| Equipment failures  |  |
| Alarm history (attach copy)   |  |
| Major maintenance activities (attach list if applicable)                |  |
| Pending work orders (attach copies)                                     |  |
| Operating problems (attach copy of operating log)                       |  |
| Comments  |  |
| <b>Security Features</b>  |  |
| Fence and gate  |  |
| External lighting   |  |
| Visibility from street  |  |
| Doors and locks   |  |
| Intrusion alarm(s)  |  |
| Signs with emergency contact information                                |  |
| Other security features   |  |
| Comments  |  |
| <b>Safety Features and Equipment</b>                                    |  |
| Signage (confined space, automatic equipment, hearing protection, etc.) |  |
| Fall protection   |  |
| Emergency communication   |  |
| Equipment hand guards   |  |
| Hand rails and kickboards   |  |
| Platforms and grating   |  |
| Tag out and lock out equipment  |  |
| Hearing protection  |  |
| Eye wash  |  |
| Chemical storage  |  |
| Comments  |  |

| <b>Lift Station Condition Assessment Checklist</b>               |  |
|--|--|
| <b>External Appearance</b>                                       |  |
| Fence  |  |
| Landscaping  |  |
| Building   |  |
| Control panels   |  |
| Other external features  |  |
| Comments   |  |
| <b>Building/Structure</b>  |  |
| Lift Station building  |  |
| Control room   |  |
| Dry well   |  |
| Wet well   |  |
| Other structures   |  |
| Comments   |  |
| <b>Instrumentation and Controls (including SCADA Facilities)</b> |  |
| Control panel  |  |
| Run time meters  |  |
| Flow meter   |  |
| Wet well level   |  |
| Alarms   |  |
| SCADA HMI/PLC  |  |
| Other instrumentation and controls                               |  |
| Comments   |  |
| <b>Electrical and Switch Gear</b>                                |  |
| Power drop   |  |
| Transformers   |  |
| Transfer switches  |  |
| Emergency generator and generator connection                     |  |
| Starters   |  |
| Variable frequency drives  |  |
| Electrical cabinets  |  |
| Conduit and wireways   |  |
| Other electrical   |  |
| Comments   |  |

| <b>Lift Station Condition Assessment Checklist</b> |  |
|--|--|
| <b>Motors</b>                                      |  |
| Lubrication  |  |
| Insulation   |  |
| Operating current                                  |  |
| Vibration and alignment                            |  |
| Other  |  |
| Comments   |  |
| <b>Pumps</b>                                       |  |
| Lubrication  |  |
| Vibration and alignment                            |  |
| Seals  |  |
| Indicated flow and discharge pressure              |  |
| Shutoff head                                       |  |
| Corrosion and leakage evidence                     |  |
| Drive shaft  |  |
| Other  |  |
| Comments   |  |
| <b>Valves and Piping</b>                           |  |
| Valve operation                                    |  |
| Valve condition                                    |  |
| Pipe condition                                     |  |
| Pipe support                                       |  |
| Other  |  |
| Comments   |  |
| <b>Other</b>                                       |  |
| Lighting   |  |
| Ventilation  |  |
| Support systems (air, water, etc.)                 |  |
| Signage  |  |
| Employee facilities                                |  |
| Sump pump  |  |
| Overhead crane                                     |  |
| Portable pump connections                          |  |
| Portable pumps                                     |  |
| Comments   |  |

## APPENDIX F

---

### Sewer System Major Equipment Inventory

### Sewer System Major Equipment Inventory

| Equipment item                  | Number Available |
|---------------------------------|------------------|
| Combination Cleaning Unit       | 1                |
| Hydraulic Cleaning Unit (Hydro) | 1                |
| CCTV Unit                       | 1                |
| Mechanical Rodder               | 3                |
| Lateral Camera Unit             | 2                |
| Lateral Chemical Treatment Unit | 1                |
| Utility Truck                   | 3                |
| Portable Trash Pump (6")        | 1                |
| Portable Trash Pump (2")        | 3                |
| Backhoe                         | 1                |
| 5 Yard Dump Truck               | 1                |
| Air Compressor                  | 2                |
| Portable Generator              | 1                |

# APPENDIX G

---

## Critical Sewer System Replacement Parts Inventory



### Critical Sewer System Replacement Parts Inventory

| Part Description               | Number in Inventory | Location          |
|--------------------------------|---------------------|-------------------|
| Pipe (VCP)                     |                     | Outside inventory |
| 4-inch 90 bend                 | 15                  |                   |
| 4-inch 1/8 bend                | 25                  |                   |
| 4-inch 1/16 bend               | 25                  |                   |
| 4-inch wye                     | 25                  |                   |
| 4-inch pipe, 1 foot            | 30                  |                   |
| 4-inch pipe, 2 foot            | 35                  |                   |
| 4-inch pipe, 4 foot            | 35                  |                   |
| 6-inch 90 bend                 | 5                   |                   |
| 6-inch 1/8 bend                | 10                  |                   |
| 6-inch wye                     | 8                   |                   |
| 6x4-inch wye                   | 22                  |                   |
| 6-inch pipe, 1 foot            | 15                  |                   |
| 6-inch pipe, 2 foot            | 8                   |                   |
| 6-inch pipe, 5 foot            | 20                  |                   |
| 8-inch 90 bend                 | 2                   |                   |
| 8-inch wye                     | 2                   |                   |
| 8x4-inch wye                   | 7                   |                   |
| 8-inch pipe, 1 foot            | 5                   |                   |
| 8-inch pipe, 6 foot            | 8                   |                   |
| 10-inch pipe, 6 foot           | 4                   |                   |
| 12-inch pipe, 6 foot           | 3                   |                   |
| 15-inch pipe, 2 foot           | 1                   |                   |
| 15-inch pipe, 6 foot           | 4                   |                   |
| Rubber couplings               |                     | Stores            |
| 4-inch                         | 50 assorted         |                   |
| 6-inch                         | 25 assorted         |                   |
| Rubber couplings               |                     | Materials Bay     |
| 4-inch                         | 80 assorted         |                   |
| 6-inch                         | 16                  |                   |
| 8-inch                         | 16                  |                   |
| 10-inch                        | 12                  |                   |
| 12-inch                        | 6                   |                   |
| 15-inch                        | 6                   |                   |
| 24-inch                        | 2                   |                   |
| Last Inventory Date: 1/31/2017 |                     |                   |

# APPENDIX H

---

## Sanitary Sewer Design Standards

**CITY OF DAVIS  
PUBLIC WORKS DEPARTMENT  
STANDARD SPECIFICATIONS**

JANUARY 1996 EDITION  
ADDENDA THROUGH  
OCTOBER 2009

ROBERT A. CLARKE  
City Engineer  
1717 Fifth Street  
Davis, CA 95616  
530-757-5686



## *TABLE OF CONTENTS*

|   |           |
|---|-----------|
| <b><i>PART ONE GENERAL CONDITIONS.....1</i></b>                             |           |
| <b>SECTION 1 GENERAL PRINCIPLES OF INTERPRETATION AND DEFINITIONS .....</b> | <b>1</b>  |
| 1-1 GENERAL PRINCIPLES OF INTERPRETATION .....                              | 1         |
| 1-2 DEFINITIONS AND TERMS .....   | 1         |
| <b>SECTION 2 PROPOSAL REQUIREMENTS AND CONDITIONS .....</b>                 | <b>4</b>  |
| 2-1 CONTENTS OF PROPOSAL FORMS .....  | 4         |
| 2-2 APPROXIMATE ESTIMATE .....  | 4         |
| 2-3 EXAMINATION OF PLANS, SPECIFICATIONS, AND SITE OF WORK .....            | 4         |
| 2-4 PROPOSAL FORMS .....  | 4         |
| 2-5 REJECTION OF PROPOSALS .....  | 5         |
| 2-6 PROPOSAL GUARANTY .....   | 5         |
| 2-7 WITHDRAWAL OF PROPOSALS .....   | 5         |
| 2-8 PUBLIC OPENING OF PROPOSALS .....                                       | 5         |
| 2-9 EXPERIENCE STATEMENT .....  | 6         |
| 2-10 CONTRACTOR'S GUARANTY .....  | 6         |
| 2-11 GUARANTY SECURITY .....  | 6         |
| 2-12 LISTING OF SUBCONTRACTORS .....  | 6         |
| 2-13 ADDENDA .....  | 7         |
| 2-14 CITY EMPLOYEES AND DESIGN CONSULTANT BID EXCLUSION .....               | 7         |
| <b>SECTION 3 AWARD AND EXECUTION OF CONTRACT .....</b>                      | <b>8</b>  |
| 3-1 AWARD OF CONTRACT .....   | 8         |
| 3-2 CONTRACT BONDS .....  | 8         |
| 3-3 EXECUTION OF CONTRACT .....   | 8         |
| 3-4 FAILURE TO EXECUTE CONTRACT .....                                       | 9         |
| 3-5 RETURN OF PROPOSAL GUARANTIES .....                                     | 9         |
| <b>SECTION 4 SCOPE OF WORK .....</b>  | <b>10</b> |
| 4-1 INTENT OF PLANS AND SPECIFICATIONS .....                                | 10        |
| 4-2 PROJECT SITE MAINTENANCE AND FINAL CLEANUP .....                        | 10        |
| 4-3 CHANGES .....   | 10        |
| 4-3.1 PROCEDURE AND PROTEST .....   | 11        |
| 4-3.2 INCREASED OR DECREASED QUANTITIES .....                               | 12        |
| 4-3.2.1 INCREASES OF MORE THAN 25 PERCENT .....                             | 12        |
| 4-3.2.2 DECREASES OF MORE THAN 25 PERCENT .....                             | 12        |
| 4-3.2.3 ELIMINATED ITEMS .....  | 13        |
| 4-3.3 CHANGES IN CHARACTER OF WORK .....                                    | 13        |
| 4-3.4 EXTRA WORK .....  | 14        |
| 4-3.5 DIFFERING SITE CONDITIONS .....                                       | 14        |
| 4-3.5.1 NOTICE REQUIREMENT .....  | 14        |
| 4-3.5.1.1 HAZARDOUS MATERIALS PER STATE LAW .....                           | 14        |
| 4-3.5.1.2 DIFFERING PHYSICAL CONDITIONS .....                               | 15        |
| 4-3.5.1.3 UNKNOWN PHYSICAL CONDITIONS .....                                 | 15        |
| 4-3.5.2 CITY INVESTIGATION AND ACTION .....                                 | 15        |
| 4-3.5.3 DISPUTES .....  | 15        |
| <b>SECTION 5 CONTROL OF WORK .....</b>                                      | <b>16</b> |
| 5-1 AUTHORITY OF CITY ENGINEER .....  | 16        |
| 5-1.1 FUNCTION OF PROJECT ENGINEER .....                                    | 16        |

|   |   |           |
|---|---|-----------|
| 5-2   | PLANS AND SHOP DRAWINGS   | 16        |
| 5-2.1   | TRENCH EXCAVATION SAFETY PLANS  | 17        |
| 5-2.2   | VARIATIONS FROM PLANS AND SPECIFICATIONS OR OTHER CONTRACT DOCUMENTS                      | 17        |
| 5-3   | CONFORMITY WITH CONTRACT DOCUMENTS AND ALLOWABLE DEVIATIONS                               | 17        |
| 5-4   | COORDINATION AND INTERPRETATION OF PLANS, STANDARD SPECIFICATIONS, AND SPECIAL PROVISIONS | 18        |
| 5-5   | ORDER OF WORK   | 18        |
| 5-6   | SUPERINTENDENCE   | 19        |
| 5-7   | LINES AND GRADES  | 19        |
| 5-8   | INSPECTION  | 19        |
| 5-8.1   | HOURS OF WORK   | 20        |
| 5-9   | REMOVAL OF REJECTED AND UNAUTHORIZED WORK   | 20        |
| 5-10  | EQUIPMENT AND PLANTS  | 20        |
| 5-11  | CHARACTER OF WORKERS  | 21        |
| 5-12  | FINAL INSPECTION  | 21        |
| 5-13  | PUNCH LIST  | 21        |
| 5-14  | SUGGESTIONS TO CONTRACTOR ADOPTED AT OWN RISK   | 21        |
| 5-15  | CONSTRUCTION ACCESS (TRUCK ROUTES)  | 21        |
| 5-16  | REMOVAL, RELOCATION OR PROTECTION OF EXISTING UTILITIES                                   | 21        |
| <b>SECTION 6 CONTROL OF MATERIALS</b>               |   | <b>23</b> |
| 6-1   | SOURCE OF SUPPLY AND QUALITY OF MATERIALS   | 23        |
| 6-2   | CITY FURNISHED MATERIALS  | 23        |
| 6-3   | SHORTAGE OF MATERIALS   | 24        |
| 6-4   | DEFECTIVE MATERIALS   | 24        |
| 6-5   | TRADE NAMES AND ALTERNATIVES  | 24        |
| 6-6   | PLANT INSPECTION  | 24        |
| 6-7   | CERTIFICATES OF COMPLIANCE  | 25        |
| 6-8   | TESTING   | 25        |
| 6-9   | CONSTRUCTION WATER  | 26        |
| 6-9.1   | CONSTRUCTION WATER ON CITY PROJECTS   | 26        |
| 6-10  | SALVAGE   | 26        |
| <b>SECTION 7 LEGAL RELATIONS AND RESPONSIBILITY</b> |   | <b>27</b> |
| 7-1   | LAWS TO BE OBSERVED   | 27        |
| 7-1.1   | HOURS OF LABOR  | 27        |
| 7-1.2   | PREVAILING WAGE   | 27        |
| 7-1.3   | PAYROLL RECORDS   | 28        |
| 7-1.4   | LABOR NONDISCRIMINATION   | 29        |
| 7-1.5   | CITY OF DAVIS FAIR EMPLOYMENT PRACTICES   | 29        |
| 7-1.5.1   | REQUIREMENT   | 29        |
| 7-1.5.2   | ACCESS TO RECORDS   | 29        |
| 7-1.5.3   | REMEDIES FOR VIOLATION  | 29        |
| 7-1.6   | EQUAL EMPLOYMENT OPPORTUNITY REQUIREMENTS   | 30        |
| 7-1.7   | APPRENTICES   | 30        |
| 7-1.8   | WORKERS' COMPENSATION   | 30        |
| 7-1.9   | CONTRACTOR'S LICENSING LAWS   | 31        |
| 7-1.10  | TRENCH SAFETY   | 31        |
| 7-1.11  | SOUND CONTROL REQUIREMENTS  | 31        |
| 7-2   | PAYMENT OF TAXES  | 32        |
| 7-3   | PERMITS AND LICENSES  | 32        |



|  |  |           |
|--|--|-----------|
| 7-4  | PATENTS  | 32        |
| 7-5  | SAFETY AND HEALTH PROVISIONS                           | 32        |
| 7-5.1  | JOBSITE TOILET FACILITIES                              | 32        |
| 7-6  | PUBLIC CONVENIENCE                                     | 33        |
| 7-7  | PUBLIC SAFETY  | 34        |
| 7-8  | USE OF EXPLOSIVES                                      | 35        |
| 7-9  | PRESERVATION OF PROPERTY                               | 35        |
| 7-10   | RESPONSIBILITY FOR DAMAGE                              | 36        |
| 7-11   | INSURANCE REQUIREMENTS                                 | 37        |
| 7-11.1   | MINIMUM SCOPE OF INSURANCE                             | 37        |
| 7-11.2   | MINIMUM LIMITS OF INSURANCE                            | 37        |
| 7-11.3   | DEDUCTIBLES AND SELF-INSURED RETENTIONS                | 38        |
| 7-11.4   | OTHER INSURANCE PROVISIONS                             | 38        |
| 7-11.4.1                                       | GENERAL LIABILITY AND AUTOMOBILE LIABILITY COVERAGE    | 38        |
| 7-11.4.2                                       | WORKERS' COMPENSATION AND EMPLOYERS LIABILITY COVERAGE | 38        |
| 7-11.4.3                                       | ALL COVERAGES  | 38        |
| 7-11.5   | ACCEPTABILITY OF INSURERS                              | 38        |
| 7-11.6   | VERIFICATION OF COVERAGE                               | 39        |
| 7-11.7   | SUBCONTRACTORS   | 39        |
| 7-12   | LEGAL ACTIONS AGAINST THE CITY                         | 39        |
| 7-13   | DISPOSAL OF MATERIAL                                   | 39        |
| 7-14   | COOPERATION  | 40        |
| 7-15   | RELIEF FROM MAINTENANCE AND RESPONSIBILITY             | 40        |
| 7-16   | CONTRACTOR'S RESPONSIBILITY FOR THE WORK MATERIALS     | 40        |
| 7-17   | ACCEPTANCE OF CONTRACT                                 | 41        |
| 7-18   | PROPERTY RIGHTS IN MATERIALS                           | 41        |
| 7-19   | PERSONAL LIABILITY                                     | 41        |
| <b>SECTION 8 PROSECUTION AND PROGRESS.....</b> |  | <b>42</b> |
| 8-1  | SUBCONTRACTING   | 42        |
| 8-1.1  | SUBCONTRACT DOCUMENTS                                  | 42        |
| 8-2  | ASSIGNMENT   | 42        |
| 8-3  | BEGINNING OF WORK                                      | 43        |
| 8-3.1  | PRE-CONSTRUCTION CONFERENCE                            | 43        |
| 8-4  | PROGRESS SCHEDULE                                      | 44        |
| 8-5  | TEMPORARY SUSPENSION OF WORK                           | 44        |
| 8-6  | TIME OF COMPLETION                                     | 45        |
| 8-7  | LIQUIDATED DAMAGES                                     | 46        |
| 8-8  | TERMINATION OF CONTROL                                 | 47        |
| 8-9  | RIGHT-OF-WAY DELAYS                                    | 48        |
| 8-10   | TERMINATION OF CONTRACT                                | 48        |
| 8-10.1   | TERMINATION PROCEDURE                                  | 48        |
| 8-10.1.1                                       | STOP WORK  | 49        |
| 8-10.1.2                                       | PERFORM WORK AS DIRECTED.                              | 49        |
| 8-10.1.3                                       | EQUIPMENT AND PLANT                                    | 49        |
| 8-10.1.4                                       | PROTECT MATERIALS                                      | 49        |
| 8-10.1.5                                       | NOTIFY SUBCONTRACTORS AND SUPPLIERS                    | 49        |
| 8-10.1.6                                       | INVENTORY LIST   | 49        |
| 8-10.1.7                                       | UNUSED MATERIALS                                       | 49        |
| 8-10.1.8                                       | OUTSTANDING CLAIMS AND LIABILITIES                     | 49        |
| 8-10.1.9                                       | FURNISH DOCUMENTATION                                  | 50        |



|  |   |           |
|--|---|-----------|
| 8-10.1.10                                | OTHER ACTIONS AS DIRECTED                                       | 50        |
| 8-10.2                                   | RESPONSIBILITY FOR DAMAGE TO MATERIALS                          | 50        |
| 8-10.2.1                                 | RELIEF AFTER PARTIAL PAYMENT                                    | 50        |
| 8-10.2.2                                 | RELIEF AFTER DELIVERY   | 50        |
| 8-10.2.3                                 | RELIEF AFTER COMPLETION   | 50        |
| 8-10.3                                   | SURETY OBLIGATION   | 50        |
| 8-10.4                                   | TOTAL COMPENSATION  | 51        |
| 8-10.4.1                                 | REASONABLE COST   | 51        |
| 8-10.4.2                                 | ALLOWANCE FOR PROFIT  | 51        |
| 8-10.4.3                                 | VENDOR COSTS  | 51        |
| 8-10.4.4                                 | ADMINISTRATIVE COSTS  | 51        |
| 8-10.5                                   | RECORDS   | 51        |
| 8-10.6                                   | INTERIM PAYMENTS  | 52        |
| 8-10.7                                   | SUBCONTRACT REQUIREMENT   | 52        |
| 8-11                                     | CITY'S RIGHT TO TAKE POSSESSION OF THE WORK IN WHOLE OR IN PART | 52        |
| 8-12                                     | COMPLETION  | 52        |
| <b>SECTION 9 MEASUREMENT AND PAYMENT</b> |   | <b>53</b> |
| 9-1                                      | MEASUREMENT OF QUANTITIES                                       | 53        |
| 9-2                                      | SCOPE OF PAYMENT  | 53        |
| 9-3                                      | FORCE ACCOUNT PAYMENT   | 54        |
| 9-3.1                                    | WORK PERFORMED BY CONTRACTOR                                    | 54        |
| 9-3.1.1                                  | LABOR   | 54        |
| 9-3.1.1.1                                | ACTUAL WAGES  | 55        |
| 9-3.1.1.2                                | LABOR SURCHARGE   | 55        |
| 9-3.1.2                                  | MATERIALS   | 55        |
| 9-3.1.2.1                                | CASH OR TRADE DISCOUNT  | 55        |
| 9-3.1.2.2                                | INDIRECT PURCHASES  | 55        |
| 9-3.1.2.3                                | SUPPLIERS OWNED BY CONTRACTOR                                   | 55        |
| 9-3.1.2.4                                | COSTS AT WHOLESALE  | 56        |
| 9-3.1.2.5                                | NO EVIDENCE OF COST   | 56        |
| 9-3.1.3                                  | EQUIPMENT RENTAL  | 56        |
| 9-3.1.3.1                                | RENTAL TIME   | 56        |
| 9-3.1.3.2                                | TRANSPORTATION COST   | 57        |
| 9-3.2                                    | RECORDS   | 57        |
| 9-3.3                                    | PAYMENT   | 58        |
| 9-4                                      | NOTICE OF POTENTIAL CLAIM                                       | 58        |
| 9-5                                      | STOP NOTICES  | 59        |
| 9-6                                      | PARTIAL PAYMENTS  | 59        |
| 9-7                                      | SUBSTITUTION OF SECURITIES FOR WITHHELD MONEY                   | 60        |
| 9-8                                      | PAYMENT AFTER ACCEPTANCE  | 60        |
| 9-8.1                                    | FINAL PAYMENT AND CLAIMS  | 60        |
| 9-9                                      | CLERICAL ERRORS   | 61        |
| 9-10                                     | RESOLUTION OF CONSTRUCTION CLAIMS                               | 62        |
| 9-10.1                                   | TIME LIMITS FOR FILING CLAIMS                                   | 62        |
| 9-10.2                                   | WRITTEN FORM OF CLAIMS  | 62        |
| 9-10.3                                   | INITIAL CITY RESPONSE TO CLAIMS                                 | 62        |
| 9-10.3.1                                 | RESPONSE TIMES FOR CLAIMS OF LESS THAN \$50,000                 | 62        |
| 9-10.3.2                                 | RESPONSE TIME FOR CLAIMS OF \$50,000 TO \$375,000               | 63        |
| 9-10.4                                   | CLAIMANT REJECTS INITIAL CITY DECISION                          | 63        |
| 9-10.4.1                                 | INFORMAL MEET AND CONFER CONFERENCE                             | 63        |

|        |                               |    |
|--------|-------------------------------|----|
| 9-10.5 | CIVIL ACTION                  | 63 |
| 9-10.6 | PAYMENT OF UNDISPUTED AMOUNTS | 63 |
| 9-10.7 | INTEREST ON CLAIM             | 63 |

|   |  |           |
|---|--|-----------|
| <b><i>PART TWO CONSTRUCTION MATERIALS</i></b> .....     |  | <b>65</b> |
| <b>SECTION 200 ROCK AND EARTH MATERIALS</b> .....       |  | <b>65</b> |
| 200-1   | AGGREGATE BASE .....                           | 65        |
| 200-2   | AGGREGATE SUBBASE .....                        | 65        |
| 200-3   | CRUSHED ROCK .....                             | 65        |
| 200-4   | DECOMPOSED GRANITE .....                       | 66        |
| 200-5   | SELECT MATERIAL .....                          | 67        |
| 200-6   | SAND .....                                     | 67        |
| 200-7   | PERMEABLE FILTER MATERIAL .....                | 67        |
| 200-8   | SLURRY CEMENT BACKFILL .....                   | 68        |
| 200-9   | SLURRY SEAL AGGREGATE .....                    | 68        |
| 200-10  | BEDDING .....                                  | 69        |
| <b>SECTION 201 CONCRETE AND RELATED MATERIALS</b> ..... |  | <b>70</b> |
| 201-1   | PORTLAND CEMENT CONCRETE .....                 | 70        |
| 201-1.1   | PORTLAND CEMENT .....                          | 70        |
| 201-1.2   | AGGREGATES .....                               | 70        |
| 201-1.3   | WATER .....                                    | 70        |
| 201-1.4   | MIXING OF CONCRETE .....                       | 70        |
| 201-1.5   | ADMIXTURES .....                               | 70        |
| 201-1.6   | POLYPROPYLENE FIBERS .....                     | 70        |
| 201-2   | REINFORCEMENT FOR CONCRETE .....               | 71        |
| 201-3   | EXPANSION JOINT FILLER .....                   | 71        |
| 201-4   | CONCRETE CURING COMPOUND .....                 | 71        |
| 201-5   | CEMENT MORTAR .....                            | 71        |
| 201-5.1   | GENERAL .....                                  | 71        |
| 201-5.2   | SAND FOR CEMENT MORTAR .....                   | 71        |
| 201-5.3   | CEMENT .....                                   | 71        |
| 201-5.4   | WATER .....                                    | 71        |
| 201-6   | PORTLAND CEMENT CONCRETE ADHESIVE .....        | 72        |
| <b>SECTION 202 BITUMINOUS MATERIALS</b> .....           |  | <b>73</b> |
| 202-1   | ASPHALT CONCRETE .....                         | 73        |
| 202-1.1   | MIX DESIGN .....                               | 73        |
| 202-1.2   | ASPHALT GRADES .....                           | 74        |
| 202-2   | EMULSIFIED ASPHALT .....                       | 76        |
| 202-3   | JOINT SEALANT FOR CONCRETE PIPE .....          | 76        |
| <b>SECTION 203 PIPE AND RELATED MATERIAL</b> .....      |  | <b>77</b> |
| 203-1   | PVC UNDERDRAIN PIPE .....                      | 77        |
| 203-2   | STORM DRAIN PIPE .....                         | 77        |
| 203-2.1   | NON-REINFORCED CONCRETE PIPE .....             | 77        |
| 203-2.2   | REINFORCED CONCRETE PIPE .....                 | 77        |
| 203-2.3   | CONCRETE FOR CAST-IN-PLACE CONCRETE PIPE ..... | 77        |
| 203-2.4   | PVC STORM DRAIN PIPE .....                     | 77        |
| 203-2.5   | CLAY STORM DRAIN PIPE .....                    | 78        |
| 203-2.6   | ASBESTOS CEMENT STORM DRAINAGE PIPE .....      | 78        |
| 203-3   | SEWER PIPE .....                               | 78        |
| 203-3.1   | VITRIFIED CLAY PIPE .....                      | 78        |
| 203-3.1.1   | COMPRESSION JOINTS .....                       | 78        |
| 203-3.1.2   | REPAIR OR SLEEVE COUPLINGS .....               | 79        |



|   |   |           |
|---|---|-----------|
| 203-3.2   | DUCTILE IRON PIPE SEWER LATERALS                      | 79        |
| 203-3.3   | PVC SEWER FORCE MAINS                                 | 79        |
| 203-4   | WATER PIPE  | 79        |
| 203-4.1   | POLYVINYL CHLORIDE (PVC) PIPE                         | 80        |
| 203-4.1.1   | PVC PIPE JOINTS                                       | 80        |
| 203-4.1.2   | PVC TO DUCTILE IRON TRANSITION                        | 81        |
| 203-4.2   | DUCTILE IRON  | 81        |
| 203-4.2.1   | DUCTILE IRON PIPE JOINTS                              | 81        |
| 203-4.3   | PIPE FITTINGS   | 82        |
| 203-4.4   | CORROSION RESISTANT FASTENINGS                        | 82        |
| 203-4.5   | LOCATING WIRE   | 82        |
| 203-4.6   | MARKING TAPE  | 83        |
| 203-5   | VALVES  | 83        |
| 203-5.1   | BUTTERFLY VALVES                                      | 83        |
| 203-5.2   | GATE VALVES   | 84        |
| 203-5.2.1   | RESILIENT SEATED TAPPING VALVES                       | 84        |
| 203-5.2.2   | STAINLESS STEEL TAPPING SLEEVES                       | 84        |
| 203-5.3   | VALVE EXTENSION                                       | 84        |
| 203-6   | FIRE HYDRANTS   | 84        |
| 203-6.1   | MAIN VALVE AND BODY                                   | 84        |
| 203-6.2   | OUTLET CONNECTIONS                                    | 85        |
| 203-6.3   | APPROVED MANUFACTURERS MODELS                         | 85        |
| 203-6.4   | PAVEMENT MARKERS                                      | 85        |
| 203-6.5   | PAINT   | 85        |
| 203-7   | WATER VALVE BOXES                                     | 85        |
| 203-8   | WATER SERVICES  | 85        |
| 203-8.1   | SIZES AND PIPE TYPES                                  | 86        |
| 203-8.1.1   | COPPER SERVICES                                       | 86        |
| 203-8.2   | SADDLES   | 86        |
| 203-8.3   | BRAZING   | 87        |
| 203-8.4   | BACKFLOW PREVENTION                                   | 87        |
| 203-8.5   | CORPORATION STOPS                                     | 87        |
| 203-8.6   | ANGLE METER STOPS                                     | 88        |
| 203-8.7   | WATER METERS  | 88        |
| 203-8.7.1   | CONSTRUCTION  | 88        |
| 203-8.7.2   | REGISTER  | 88        |
| 203-8.7.3   | MAGNETIC DRIVE  | 89        |
| 203-8.7.4   | STRAIGHTENING VANES                                   | 89        |
| 203-8.7.5   | APPROVED MANUFACTURERS MODELS                         | 89        |
| 203-8.8   | BOXES FOR WATER METERS                                | 89        |
| 203-8.9   | WATER METER LABELS                                    | 89        |
| 203-9   | BLOWOFF VALVES  | 89        |
| 203-10  | MAINTENANCE HOLES                                     | 90        |
| 203-10.1  | STANDARD MAINTENANCE HOLES (SANITARY AND STORM DRAIN) | 90        |
| 203-10.2  | LINED SANITARY SEWER MAINTENANCE HOLES                | 90        |
| <b>SECTION 204 MISCELLANEOUS METAL AND CASTINGS .....</b> |   | <b>91</b> |
| 204-1   | METAL RAILINGS AND BARRIERS                           | 91        |
| 204-2   | CHAIN LINK FENCE                                      | 91        |
| 204-3   | MAINTENANCE HOLE LIDS AND CASTINGS                    | 91        |
| 204-4   | MONUMENT LIDS AND CASTINGS                            | 91        |

|   |           |
|---|-----------|
| <b>SECTION 205 STRIPING AND TRAFFIC SIGNING MATERIALS .....</b> | <b>92</b> |
| 205-1 TRAFFIC PAINT AND RELATED MATERIALS _____                 | 92        |
| 205-2 TRAFFIC PAINT _____                                       | 92        |
| 205-2.1 GENERAL _____   | 92        |
| 205-2.2 WHITE, YELLOW, AND BLACK PAINT _____                    | 92        |
| 205-2.3 GLASS BEADS _____                                       | 92        |
| 205-2.4 PAVEMENT MESSAGES _____                                 | 92        |
| 205-3 TRAFFIC SIGNS _____                                       | 93        |
| 205-3.1 GENERAL _____   | 93        |
| 205-3.2 METAL POSTS _____                                       | 93        |
| 205-3.3 WOOD POSTS _____  | 93        |
| 205-3.4 MISCELLANEOUS FASTENING HARDWARE _____                  | 93        |
| <b>SECTION 206 STREETLIGHT MATERIALS .....</b>                  | <b>94</b> |
| 206-1 GENERAL _____   | 94        |
| 206-1.1 REGULATIONS AND CODES _____                             | 94        |
| 206-1.2 DEFINITIONS _____                                       | 94        |
| 206-1.3 STANDARD PLANS _____                                    | 94        |
| 206-2 HIGH PRESSURE SODIUM LUMINAIRES _____                     | 95        |
| 206-3 POLES _____   | 95        |
| 206-4 CONDUIT _____   | 96        |
| 206-4.1 METAL CONDUIT _____                                     | 96        |
| 206-4.2 PLASTIC CONDUIT _____                                   | 96        |
| 206-5 WIRING (CONDUCTORS) _____                                 | 96        |
| 206-6 PULL BOXES _____  | 97        |

***PART THREE CONSTRUCTION METHODS..... 99***

**SECTION 300 REMOVALS, EXCAVATION AND EARTHWORK..... 99**

300-1 CLEARING AND GRUBBING ..... 99

300-1.1 GENERAL ..... 99

300-1.2 CLEARING AND GRUBBING OPERATION ..... 99

300-1.3 REMOVAL AND DISPOSAL OF MATERIALS ..... 99

300-1.4 WATER WELL ABANDONMENT AND DESTRUCTION ..... 100

300-2 ROADWAY EXCAVATION ..... 100

300-2.1 GENERAL ..... 100

300-2.2 UNSUITABLE MATERIAL ..... 100

300-2.3 SLOPES ..... 101

300-3 EARTH FILL CONSTRUCTION ..... 101

300-3.1 GENERAL ..... 101

300-3.2 COMPACTION REQUIREMENTS ..... 102

300-3.3 COMPACTION TESTING ..... 102

300-4 STRUCTURE EXCAVATION AND BACKFILL ..... 102

300-4.1 GENERAL ..... 102

300-4.2 FOUNDATION MATERIAL TREATMENT ..... 102

300-4.3 INSPECTION ..... 103

300-4.4 STRUCTURE BACKFILL ..... 103

300-4.5 MATERIAL SUBSTITUTIONS ..... 103

**SECTION 301 SUBGRADE PREPARATION AND PLACEMENT OF BASE MATERIALS. 104**

301-1 SUBGRADE PREPARATION ..... 104

301-1.1 CONSTRUCTION TIMING ..... 104

301-1.2 CONSTRUCTION STAKING FOR SUBGRADE INSPECTION ..... 104

301-1.3 SUBGRADE PREPARATION ..... 104

301-1.4 COMPACTION ..... 105

301-1.5 TOLERANCES ..... 105

301-1.6 INSPECTION ..... 105

301-2 AGGREGATE SUBBASE AND AGGREGATE BASE ..... 105

301-2.1 SPREADING ..... 105

301-2.2 COMPACTION AND TOLERANCES ..... 106

301-2.3 PROTECTION OF AGGREGATE BASE ..... 106

**SECTION 302 ROADWAY SURFACING..... 107**

302-1 ASPHALT CONCRETE PAVEMENT ..... 107

302-1.1 GENERAL ..... 107

302-1.2 DISTRIBUTION AND SPREADING ..... 107

302-1.3 JOINTS ..... 108

302-1.4 TACK COAT ..... 108

302-1.5 PLACING ASPHALT ..... 108

302-1.5.1 ROLLING ..... 108

302-1.5.2 ADJUSTMENTS ..... 110

302-1.5.3 ACCEPTANCE SAMPLING AND TESTING OF ASPHALTIC CONCRETE ..... 110

302-1.5.4 DENSITY AND SMOOTHNESS ..... 110

302-1.7 FOG SEAL ..... 111

302-1.8 BIKEPATH SEAL COAT ..... 111

302-1.8.1 WEATHER AND TEMPERATURE ..... 111

302-1.8.2 SURFACE CLEANING ..... 111



|  |   |            |
|--|---|------------|
| 302-1.8.3  | MIXING  | 111        |
| 302-1.8.4  | APPLICATION PROCEDURE                                     | 111        |
| 302-1.8.5  | RATE OF APPLICATION                                       | 112        |
| 302-2  | SLURRY SEAL   | 112        |
| 302-2.1  | GENERAL   | 112        |
| 302-2.2  | MIXING EQUIPMENT  | 112        |
| 302-2.3  | SPREADING EQUIPMENT                                       | 113        |
| 302-2.4  | PROPORTIONING   | 113        |
| 302-2.5  | PLACEMENT   | 113        |
| <b>SECTION 303 PORTLAND CEMENT CONCRETE CONSTRUCTION</b> |   | <b>114</b> |
| 303-1  | CONCRETE CURB, GUTTER, SIDEWALK AND DRIVEWAY CONSTRUCTION | 114        |
| 303-1.1  | GENERAL   | 114        |
| 303-1.2  | MIXING AND DELIVERY OF CONCRETE                           | 114        |
| 303-1.3  | ADMIXTURES  | 114        |
| 303-1.4  | POLYPROPYLENE FIBERS IN CONCRETE                          | 115        |
| 303-1.5  | SUBGRADE PREPARATION                                      | 115        |
| 303-1.6  | FORMS   | 115        |
| 303-1.7  | SLIP FORM EQUIPMENT                                       | 115        |
| 303-1.8  | CONSTRUCTION JOINTS                                       | 116        |
| 303-1.9  | DEEP TOOL JOINTS  | 116        |
| 303-1.10   | PLACING OF CONCRETE AND FINISHING                         | 116        |
| 303-1.11   | MARKINGS FOR SERVICES                                     | 117        |
| 303-1.12   | CURING OF CONCRETE  | 117        |
| 303-1.13   | REPAIRS AND REPLACEMENT OF CONCRETE                       | 117        |
| 303-1.14   | EXTRUDED BARRIER CURB                                     | 117        |
| 303-2  | CONCRETE STRUCTURES                                       | 117        |
| <b>SECTION 304 UNDERGROUND PIPELINE CONSTRUCTION</b>     |   | <b>118</b> |
| 304-1  | DEFINITIONS   | 118        |
| 304-1.1  | TRENCH DEFINITION   | 118        |
| 304-1.2  | APPURTENANT EXCAVATION                                    | 118        |
| 304-1.3  | ADDITIONAL DEFINITIONS                                    | 118        |
| 304-2  | GENERAL REQUIREMENTS                                      | 118        |
| 304-3  | SAFETY  | 119        |
| 304-3.1  | GENERAL   | 119        |
| 304-3.2  | SHORING AND BRACING                                       | 119        |
| 304-3.3  | ACCESS TO TRENCHES  | 120        |
| 304-4  | HORIZONTAL AND VERTICAL ALIGNMENT                         | 120        |
| 304-5  | EXCAVATION  | 120        |
| 304-5.1  | MAXIMUM LENGTH OF OPEN TRENCH                             | 120        |
| 304-5.2  | TRENCH WIDTH  | 121        |
| 304-5.3  | OVEREXCAVATION  | 121        |
| 304-6  | BACKFILL AND COMPACTION                                   | 121        |
| 304-6.1  | GENERAL   | 121        |
| 304-6.2  | BEDDING   | 122        |
| 304-6.3  | INITIAL BACKFILL  | 122        |
| 304-6.4  | FINAL BACKFILL  | 122        |
| 304-6.5  | COMPACTION  | 123        |
| 304-6.5.1  | BACKFILL COMPACTION BY MECHANICAL METHODS                 | 124        |
| 304-6.5.2  | BACKFILL COMPACTION BY WATER-JETTING                      | 124        |
| 304-7  | TEMPORARY AND PERMANENT RESURFACING                       | 125        |



|   |            |
|---|------------|
| <b>SECTION 305 WATER SYSTEMS .....</b>                            | <b>127</b> |
| 305-1 TRENCH EXCAVATION AND BACKFILL .....                        | 127        |
| 305-2 HANDLING OF MATERIALS .....                                 | 127        |
| 305-3 LINE AND GRADE .....  | 127        |
| 305-4 TRENCH BOTTOM .....   | 127        |
| 305-5 PIPE LAYING .....   | 128        |
| 305-5.1 PVC PIPE INSTALLATION .....                               | 128        |
| 305-6 JOINT ASSEMBLY .....  | 129        |
| 305-7 POLYETHYLENE ENCASEMENT .....                               | 129        |
| 305-8 VALVES AND HYDRANTS .....                                   | 129        |
| 305-9 THRUST BLOCKS .....   | 130        |
| 305-10 INSTALLATION OF SERVICES .....                             | 130        |
| 305-10.1 SERVICE TAPS .....                                       | 130        |
| 305-10.2 SERVICE SADDLE INSTALLATION .....                        | 130        |
| 305-10.3 CORPORATION STOP INSTALLATION .....                      | 130        |
| 305-10.4 SERVICE LINE INSTALLATION .....                          | 131        |
| 305-10.5 WATER METER INSTALLATION .....                           | 131        |
| 305-10.6 TIE-IN LARGE DIAMETER WATER MAINS OR SERVICE MAINS ..... | 132        |
| 305-11 BLOWOFFS .....   | 132        |
| 305-12 DISINFECTION AND FLUSHING .....                            | 132        |
| 305-13 PRESSURE TEST AND LEAK TEST .....                          | 132        |
| 305-14 CONNECTIONS .....  | 134        |
| 305-15 INSTALLATION OF VALVE BOXES .....                          | 134        |
| 305-16 ABANDONMENT OF SERVICES .....                              | 134        |
| 305-17 REPAIRING INSTALLED IMPROVEMENTS .....                     | 135        |
| <b>SECTION 306 SEWER SYSTEMS .....</b>                            | <b>136</b> |
| 306-1 TRENCH EXCAVATION AND BACKFILL .....                        | 136        |
| 306-2 GENERAL .....   | 136        |
| 306-3 LINE AND GRADE .....  | 136        |
| 306-4 BEDDING .....   | 136        |
| 306-5 PIPE LAYING .....   | 136        |
| 306-5.1 MARKING .....   | 138        |
| 306-6 JOINTING OF PIPE .....                                      | 138        |
| 306-7 SEWER SERVICES .....  | 138        |
| 306-8 FLUSHER BRANCHES .....                                      | 138        |
| 306-9 MAINTENANCE HOLES .....                                     | 138        |
| 306-10 REPAIRS .....  | 139        |
| 306-11 INSTALLATION OF SEWER TAPS .....                           | 139        |
| 306-12 CLEANING AND FLUSHING .....                                | 139        |
| 306-13 TESTING AND ACCEPTANCE .....                               | 139        |
| 306-13.1 AIR PRESSURE TEST .....                                  | 140        |
| 306-13.2 CLOSED CIRCUIT TELEVISION INSPECTION .....               | 140        |
| 306-14 ABANDONMENT OF SERVICES .....                              | 141        |
| <b>SECTION 307 STORM DRAINAGE SYSTEMS .....</b>                   | <b>142</b> |
| 307-1 TRENCH EXCAVATION AND BACKFILL .....                        | 142        |
| 307-2 PRECAST MANUFACTURED PIPE .....                             | 142        |
| 307-2.1 LINE AND GRADE .....                                      | 142        |
| 307-2.2 PLACEMENT .....   | 142        |
| 307-2.3 JOINTS, CONCRETE TONGUE AND GROOVE PIPE .....             | 143        |

|  |   |            |
|--|---|------------|
| 307-2.3.1  | MORTAR JOINTS                                     | 143        |
| 307-2.3.2  | JOINTS USING JOINT SEALANT                        | 143        |
| 307-2.4  | JOINTS, CONCRETE BELL AND SPIGOT PIPE             | 143        |
| 307-2.5  | JOINTS, ASBESTOS-CEMENT PIPE                      | 144        |
| 307-3  | CAST-IN-PLACE NON-REINFORCED CONCRETE PIPE (CIPP) | 144        |
| 307-3.1  | GENERAL   | 144        |
| 307-3.2  | MATERIALS   | 145        |
| 307-3.3  | EXCAVATION  | 146        |
| 307-3.4  | PLACEMENT   | 146        |
| 307-3.4.1  | GENERAL   | 146        |
| 307-3.4.2  | CONSTRUCTION JOINTS                               | 147        |
| 307-3.4.3  | FORM REMOVAL                                      | 147        |
| 307-3.4.4  | FINISHING   | 147        |
| 307-3.4.5  | CURING  | 147        |
| 307-3.4.6  | REPAIRING   | 147        |
| 307-3.5  | BACKFILL  | 148        |
| 307-3.6  | DIMENSIONS AND TOLERANCES                         | 148        |
| 307-3.6.1  | MINIMUM SIZE CIPP                                 | 148        |
| 307-3.6.2  | DIAMETER  | 148        |
| 307-3.6.3  | WALL THICKNESS                                    | 148        |
| 307-3.6.4  | OFFSETS AND INDENTATIONS                          | 148        |
| 307-3.6.5  | LINE AND GRADE                                    | 149        |
| 307-3.6.6  | LINES ADJACENT TO EXISTING WATER LINES            | 149        |
| 307-3.7  | TEST REQUIREMENTS                                 | 149        |
| 307-3.7.1  | SEQUENCE OF SAMPLING AND TESTING                  | 149        |
| 307-3.7.2  | SLUMP TESTS                                       | 149        |
| 307-3.7.3  | CONCRETE CYLINDERS                                | 150        |
| 307-3.7.4  | THICKNESS   | 150        |
| 307-3.7.5  | CONCRETE CORES                                    | 150        |
| 307-4  | STREET UNDERDRAINS                                | 150        |
| 307-4.1  | TIMING OF CONSTRUCTION                            | 150        |
| 307-4.2  | LOCATION  | 151        |
| 307-4.3  | EXCAVATION  | 151        |
| 307-4.4  | FABRIC PLACEMENT                                  | 151        |
| 307-4.5  | DRAIN ROCK AND PIPE PLACEMENT                     | 151        |
| 307-4.6  | DROP INLET CONNECTION                             | 151        |
| 307-4.7  | END OF LINE CLEANOUT                              | 152        |
| <b>SECTION 308 TRAFFIC STRIPING, DELINEATION AND SIGNS .....</b> |   | <b>153</b> |
| 308-1  | TRAFFIC STRIPING AND MESSAGES                     | 153        |
| 308-1.1  | PAVEMENT OVERLAY WORK                             | 153        |
| 308-1.2  | NEW WORK  | 153        |
| 308-1.3  | TEMPORARY DELINEATION                             | 153        |
| 308-1.4  | REMOVAL OF EXISTING STRIPING AND PAVEMENT MARKERS | 153        |
| 308-1.5  | PERMANENT STRIPING AND MARKING                    | 154        |
| 308-1.5.1  | GENERAL   | 154        |
| 308-1.5.2  | EQUIPMENT   | 154        |
| 308-1.5.3  | LAYOUT  | 154        |
| 308-1.5.4  | APPLICATION                                       | 155        |
| 308-1.5.5  | CLEANUP   | 155        |
| 308-2  | TRAFFIC SIGNS                                     | 155        |



|  |                                     |            |
|--|-------------------------------------|------------|
| 308-2.1  | STANDARD PLANS                      | 155        |
| 308-2.2  | POST INSTALLATION                   | 155        |
| 308-2.3  | SIGN PANEL INSTALLATION             | 155        |
| <b>SECTION 309 STREETLIGHT INSTALLATION.....</b> |                                     | <b>157</b> |
| 309-1  | GENERAL                             | 157        |
| 309-2  | REGULATIONS AND CODES               | 157        |
| 309-3  | SHOP DRAWING SUBMITTALS             | 157        |
| 309-4  | PROTECTION OF PROPERTY              | 157        |
| 309-4.1  | GENERAL                             | 157        |
| 309-4.2  | EXISTING LIGHTING SYSTEMS           | 158        |
| 309-4.3  | REMOVING AND REPLACING IMPROVEMENTS | 158        |
| 309-4.4  | SALVAGED ELECTRICAL EQUIPMENT       | 158        |
| 309-5  | UNDERGROUND CONDUIT INSTALLATION    | 158        |
| 309-5.1  | GENERAL                             | 158        |
| 309-5.2  | EXCAVATION                          | 159        |
| 309-5.2.1  | GENERAL                             | 159        |
| 309-5.2.2  | ROCK-WHEEL TRENCHING                | 159        |
| 309-5.3  | CONDUIT INSTALLATION                | 159        |
| 309-5.4  | PULL BOX INSTALLATION               | 160        |
| 309-5.5  | BACKFILL                            | 160        |
| 309-5.5.1  | STREET AREAS                        | 160        |
| 309-5.5.2  | NON-STREET AREAS                    | 161        |
| 309-5.5.3  | NARROW TRENCHES IN EXISTING STREETS | 161        |
| 309-6  | STREETLIGHT INSTALLATION            | 161        |
| 309-6.1  | LOCATION                            | 161        |
| 309-6.2  | STANDARD PLANS                      | 162        |
| 309-6.3  | FOUNDATIONS                         | 162        |
| 309-6.4  | POLES                               | 162        |
| 309-6.5  | LUMINAIRE                           | 163        |
| 309-7  | ELECTRICAL WIRING                   | 163        |
| 309-7.1  | CONDUITS                            | 163        |
| 309-7.2  | CONDUCTOR INSTALLATION              | 163        |
| 309-7.3  | CONDUCTOR SUPPORT                   | 163        |
| 309-7.4  | CONNECTORS                          | 164        |
| 309-7.5  | SPLICES                             | 164        |
| 309-7.6  | FUSED SPLICE CONNECTOR              | 164        |
| 309-7.7  | BONDING AND GROUNDING               | 164        |
| 309-8  | TESTING                             | 165        |
| 309-9  | PG&E SERVICE                        | 165        |



# PART ONE

## GENERAL CONDITIONS

### SECTION 1

#### GENERAL PRINCIPLES OF INTERPRETATION AND DEFINITIONS

##### 1-1 GENERAL PRINCIPLES OF INTERPRETATION

Working titles having a masculine gender, such as “workman” and “journeyman” and the pronoun “he,” are utilized in the Specifications for the sake of brevity, and are intended to refer to persons of either sex.

##### 1-2 DEFINITIONS AND TERMS

Unless the context otherwise requires, wherever in the Specifications and other Contract Documents, the following abbreviations and terms, or pronouns in place of them, are used, the intent and meaning shall be interpreted as provided in this Section.

**AGREEMENT** means that portion of the Contract by which the Contractor, in terms, is bound to perform the work covered by the entire contract.

**BID AND BID FORM** means Proposal.

**BIDDER** means any person, partnership, firm or corporation submitting a Proposal for the work contemplated, acting directly or through a duly authorized representative.

**CITY** is City of Davis, a Municipal Corporation, existing under and by virtue of the laws of the State of California.

**CITY CLERK** is the City Clerk of the City of Davis.

**CITY COUNCIL** means the City Council of the City of Davis.

**CITY ENGINEER** is the Public Works Director acting either directly or through properly authorized agents, such agents acting within the scope of the particular duties delegated to them.

**CONTRACT CHANGE ORDER** or **CHANGE ORDER** means a supplemental written agreement which amends or extends the Contract work. See Contract.

**CONTRACT OR CONTRACT DOCUMENTS** means a written agreement covering the performance of the work and the furnishing of labor and materials in the construction of the work. The Contract Documents shall include the Notice Inviting Bids, Information to Bidders, all duly issued Addenda, Proposal, Plans, Specifications, Agreement, and Contract Bonds. It will also include any and all

supplemental agreements (i.e., Change Orders) amending or extending the work contemplated and which may be required to complete the work in a substantial and acceptable manner.

CONTRACT PLANS see Plans.

CONTRACTOR is the Bidder who has entered into a contract with the City to perform work, or legal representative, successor, assign, executor, or heir.

DAYS shall mean consecutive calendar days unless otherwise specified.

DEPARTMENT is the Public Works Department of the City of Davis as designated by the Davis City Council.

INSPECTOR means the City Engineer or technical inspector or inspectors duly authorized and appointed by the City Council or City Engineer.

MANUAL ON UNIFORM TRAFFIC CONTROL DEVICES (MUTCD) means the Manual on Uniform Traffic Control Devices of the State of California, Department of Transportation, latest edition.

PROPOSAL is the offer of the Bidder for the work when made out and submitted on the prescribed Proposal form, properly signed and guaranteed.

PLANS are the drawings, profiles, cross-sections, working drawings, and supplemental drawings, or reproductions thereof, prepared and approved by the City Engineer, which show the location, character, dimensions and details of the work.

PROJECT ENGINEER, CONSULTING ENGINEER, CIVIL ENGINEER, MECHANICAL ENGINEER, STRUCTURAL ENGINEER, PROJECT ARCHITECT, ARCHITECT, LANDSCAPE ARCHITECT, and/or any other titles used in a set of Special Provisions on a City project, are the private consultants, whether an Engineering or Architectural firm, engaged as an independent contractor by the City to design the project and provide other professional consulting services. Whenever the Special Provisions refer to one of these consultants, it shall be interpreted to be the City Engineer and/or Public Works Inspector assigned to this project. The City Engineer (Public Works Inspector) will coordinate all review of submittals, construction observations, and/or meeting attendance by any of the project consultants.

The authority of such consultants to monitor and review the work shall be strictly limited to that authority specified, and no additional authority has been granted, nor shall be inferred.

SHOP DRAWINGS mean the detail fabrication plans, working drawings, catalog cuts, design calculations, required certificates, or other information required to completely define a particular contract item. The Contractor is required to prepare and submit these items for review and approval of the City Engineer.

SPECIAL PROVISIONS are any provisions which supplement or modify these Standard Specifications.



SPECIFICATIONS are the directions, provisions and requirements contained in these Standard Specifications as supplemented by the Special Provisions.

STANDARD PLANS are the details of standard structures, devices or instructions referred to on the Plans or in the Specifications by title or number.

STATE SPECIFICATIONS mean State of California, Department of Transportation, (more commonly known as CALTRANS), Standard Specifications, latest edition.

SUBCONTRACTOR means each person or firm who is required by law to be and who is licensed to and will perform work, labor, or render services to the Prime Contractor in or about the construction of the work, or who, under subcontract to the Prime Contractor, specifically fabricates and installs a portion of the work or improvement.

Subcontractor shall include all persons or firms within the authority of the Subletting and Subcontracting Fair Practices Act, Chapter 4 of Part 1, Division 2 of the Public Contract Code, commencing with Section 4100.

TECHNICAL SPECIFICATIONS are the general information, materials, and methods specific to a project which supplement or modify the Standard Specifications.

UTILITY means tracks, overhead or underground wires, pipelines, conduits, ducts, or structures, sewers or storm drains owned, operated, or maintained in or across a public right-of-way or private easement, whether existing or proposed.

THE WORK refers to and indicates all the work to be done under Contract, unless some other meaning is indicated by the context.



## **SECTION 2 PROPOSAL REQUIREMENTS AND CONDITIONS**

### **2-1 CONTENTS OF PROPOSAL FORMS**

Prospective Bidders will be furnished with Proposal forms. These forms will state the locations and description of the contemplated construction and will show the approximate quantities of the various kinds of work to be performed or materials to be furnished. It will also include a schedule of items for which bid prices are requested.

### **2-2 APPROXIMATE ESTIMATE**

The quantities given in the Notice to Contractors, Proposal and Contract forms are approximate only, being given as a basis for comparison of bids. The City of Davis does not, expressly or by implication, agree that the actual amount of work will correspond therewith. The City also reserves the right to increase or decrease the amount of any class or portion of the work, or to delete any portion of the work, as may be deemed necessary or advisable by the City Engineer.

### **2-3 EXAMINATION OF PLANS, SPECIFICATIONS, AND SITE OF WORK**

The Bidder shall examine carefully the site of the contemplated work as well as the Proposal, Plans, Specifications, and Contract forms therefor. It will be assumed that the Bidder has satisfactorily investigated the conditions to be encountered, the character, quality, and quantities of work to be performed and materials to be furnished, and the requirements of these Specifications and the Contract. After the signing of the Agreement, no consideration will be given to any claims of misunderstanding of the work or of any provisions of the Proposal, Plans, Specifications and Contract documents.

### **2-4 PROPOSAL FORMS**

All Proposals shall be made upon blank forms obtained from the Public Works Department (mailing address: 23 Russell Boulevard, Davis, CA 95616). The Bidder shall submit a Proposal on the forms furnished by the City. Proposals submitted on forms other than the one issued to the Bidder will be disregarded. The Proposal shall set forth for each item of work, in clear legible figures, the item price and total for each item. The Bidder shall fill out all blanks in the Proposal form as therein required.

The Proposal forms are bound in a Contract Book together with Notice Inviting Bids, Information to Bidders, Special Provisions and Contract forms. The Proposal Forms may be separated from the remainder of the Contract Documents and submitted separately to the City as the "Bid Documents." The Proposal Forms submitted with the Bid shall consist of the following documents: Proposal Form, including itemized Bid List; Experience Statement; List of Subcontractors; Non-Collusion Affidavit; any Addenda, and, Bid Security. The remainder of the Contract Documents are understood to be included by reference and shall be interpreted as being included in their entirety in the Bid Proposal.

The Proposal must be signed with the full name of the Bidder; if a partnership, by a member of the firm; if a limited partnership, by a general partner; if a corporation, by the appropriate officer thereof in the corporate name with the seal attached. When Proposals are signed by an agent, other than the officer or officers of a corporation authorized to sign contracts on its behalf, or a member of a partnership, a "Power of Attorney" must be on file with the City prior to opening bids, or shall be submitted with the Proposal. All Proposals otherwise submitted will be rejected as irregular and unauthorized.

The address of the Bidder must be given on the Proposal, and any addenda issued must be acknowledged by signature and must accompany the Proposal, when submitted to the City Clerk.

Proposals must be enclosed in a sealed envelope marked "Proposal" stating the nature and title of the work bid upon. It shall be delivered to the City Clerk of the City of Davis in conformity with the official call for bids. Proposals shall be delivered to the City Clerk at City Hall, 23 Russell Boulevard, Davis, California (corner of Fifth and "B" Streets).

## **2-5 REJECTION OF PROPOSALS**

Proposals may be rejected if they show any alteration of form, additions not called for, conditional bids, incomplete bids, erasures or irregularities of any kind.

## **2-6 PROPOSAL GUARANTY**

All Proposals shall be accompanied by cash, cashier's check, certified check or Bidder's bond, made payable to the City of Davis. The amount of said requirement shall be not less than ten (10%) percent of the amount of the attached bid. The Bidder's bond shall be executed by a corporation, as surety, authorized to issue surety bonds in the State of California. This requirement is a guaranty that, if awarded the Contract, the Bidder will sign the Agreement to do the work. In the event of the Bidder's failure to sign the Contract, after such award for the work, the cash, check or Bidder's bond shall be forfeited to the City of Davis as liquidated damages. The parties hereby agree and acknowledge that it is impossible or extremely impractical to figure damages in such event.

## **2-7 WITHDRAWAL OF PROPOSALS**

Any bid may be withdrawn at any time prior to the hour fixed in the Notice Inviting Bids for the opening of bids. A written request for the withdrawal of the bid shall be filed with the City Clerk, and shall be executed by the Bidder or his duly authorized representative. The withdrawal of a bid shall not prejudice the right of a Bidder to file a new bid.

Whether or not the bids are opened exactly at the time fixed in the Public Notice for Opening Bids, a bid will not be received after that time, nor may any bid be withdrawn after the bid opening time.

## **2-8 PUBLIC OPENING OF PROPOSALS**

Proposals will be opened and read publicly at the time and place indicated in the Notice Inviting Bids. Bidders or their authorized agents are invited to be present.



**2-9 EXPERIENCE STATEMENT**

A record of the Bidder's experience in construction of a type similar to that contemplated under this Contract shall be set forth in the Bid documents. It is the intent of the City to award the Contract to the Bidder who furnishes satisfactory evidence of having the requisite experience and ability, and of having sufficient capital, facilities, and plant to enable him to prosecute the work successfully and properly, as well as to complete it within the time named in the Contract.

To determine the degree of responsibility to be credited to the Bidder, the City will weigh evidence that the Bidder has satisfactorily performed other contracts of like nature, magnitude, and comparable difficulty and rates of progress.

A record of the Bidder's experience in construction of a type similar to that contemplated under this Contract shall be set forth in the Bid documents.

**2-10 CONTRACTOR'S GUARANTY**

Unless otherwise specified in the Special Provisions, the Contractor shall unconditionally guaranty all materials, workmanship, and equipment against defect for a period of one calendar year.

During this unconditional guaranty period, the Contractor shall, upon the receipt of notice in writing from the City, promptly make all repairs caused by defective materials, workmanship or equipment.

By executing the Contract Documents, the Contractor agrees that the City is authorized to provide for such repairs if, ten days after receipt of written notice from the City, the Contractor has failed to make or undertake with due diligence the repairs. In the case of an emergency, where, in the opinion of the City Engineer, delay could cause serious loss or damage, repairs may be made by the City without notice being sent to the Contractor, and all expense associated therewith shall be charged to the Contractor.

Nothing in this Section shall be construed to be a waiver of any additional rights or remedies available to the City through local, state and federal ordinances and codes.

**2-11 GUARANTY SECURITY**

When required by the project Special Provisions, the Contractor shall file with the City a Guaranty Security, prior to acceptance of the work as complete. The Security shall be in American dollars and shall be either a Letter of Credit executed by a surety authorized to do business in the State of California, and in a form acceptable to the City, or cash, or a cashier's check, or a Certificate of Deposit. The Security shall be in the amount as specified in the project Special Provisions or as required by the City Engineer. The term of the Security shall be for one year, commencing on the date of completion of the Contract, as said date is determined by the Notice of Completion.

**2-12 LISTING OF SUBCONTRACTORS**

Each Bidder making a bid to perform work described in these specifications shall comply with the requirements of the Subletting and Subcontracting Fair Practices Act (Public Contract Code Section

4100 et seq.), which forbids bid shopping and bid pedaling and which requires accurate listing of all subcontractors.

The Bid shall set forth the name and location of the mill, shop or office of each subcontractor who will perform work or labor or render service to the Contractor in or about the construction of the work or improvement, and the portion of the work which will be done by each subcontractor. This listing is required for subcontractors who will perform work or labor or render service of a value of more than 1/2 percent of the total bid, regardless of the amount.

Should the Contractor violate any of the provisions of the Subletting and Subcontracting Fair Practices Act, such violation shall be deemed a breach of this Contract. The City shall have all remedies provided by California law, including but not limited to, those provided in Public Contract Code Section 4110, allowing termination of the Contract or a penalty assessment of ten percent of the subcontract.

### **2-13            ADDENDA**

The City may, when it deems necessary, issue addenda to the Plans and Specifications to amend, clarify or correct matter contained therein. Such addenda shall constitute a part of said Plans and Specifications and shall be equally binding with them. Addenda shall be forwarded to all prospective Bidders.

### **2-14            CITY EMPLOYEES AND DESIGN CONSULTANT BID EXCLUSION**

No City Employee shall be eligible to submit a proposal for, nor to subcontract for any portion of, nor to supply any materials for any contract administered by the City.

No engineering, architectural firm, or other professional design consultant, which has provided design services on this project, shall be eligible to submit a proposal for the contract to construct the project, nor to subcontract for any portion of the work. The ineligible firms include the prime contractor for the design, any subcontractors of portions of the design, and affiliates of either. An affiliate is a firm which is subject to the control of the same persons, through joint ownership or other form of control.



## **SECTION 3 AWARD AND EXECUTION OF CONTRACT**

### **3-1 AWARD OF CONTRACT**

Time and price will be considered in making the award. In the event a Bidder to whom an award is made hereunder fails or refuses to enter into the Contract, the City may award the work to any other Bidder, time and price considered, or it may re-advertise the same. The City reserves the right to reject any and all Proposals and to waive any irregularities in any Proposal. The award, if made, will be made within 45 days after the opening of the Proposals. All bids will be compared on the basis of the Engineer's Estimate of the quantities of work to be done.

### **3-2 CONTRACT BONDS**

Coincident with the signing of the Agreement in duplicate, the Contractor shall file with the City a Performance Bond and a Labor and Material Bond. The Bonds shall be executed by a surety, authorized to do business in the State of California, listed in the current Federal Department of Treasury Circular 570, and shall be acceptable to the City of Davis. The Performance Bond shall be equal to one hundred 100 percent of the contract price. The Labor and Material Bond shall be equal to fifty 50 percent of the contract price. All Bonds shall be in American dollars.

The Labor and Materials Bond shall comply in all respects with the requirements of Civil Code Sections 3247 through 3252, inclusive and shall secure the payment of the claims of laborers, mechanics or material suppliers employed on the work under the Contract. The Performance Bond shall guarantee the faithful performance of all requirements of the Contract by the Contractor.

No change or alteration of the work or modification of the contract between the City and the Contractor shall release or exonerate any surety or sureties upon said bonds. For the purpose of protecting the City against any failure of the Contractor to perform the contract and make full payment thereunder for all work done and materials furnished, the principal and sureties on said bonds, in consideration of the approval thereof by the City, shall expressly recite and covenant therein that if, in the opinion of the City, any change of the conditions surrounding said work, any increase in the total amount of cost thereof, or any diminution of the security furnished by said bonds renders the same insufficient, such additional security as may be required by the City shall be furnished by the principal on said bonds within ten days after notice of such requirement, and that default in the furnishing of such additional security shall be deemed a breach of the contract on the part of the Contractor, and that no change in the plans or specifications and no agreement for reduced, added or extra work in accordance with the provisions therefore, whether with or without notice to or consent by the sureties, shall relieve any of the parties to said bonds.

### **3-3 EXECUTION OF CONTRACT**

Upon the award of the Contract, the successful Bidder will be promptly notified of the award, and shall, within ten calendar days from the date of receiving such notification, sign the Agreement in duplicate and deliver the same to the City.

**3-4 FAILURE TO EXECUTE CONTRACT**

Failure to execute the Contract and file acceptable Bonds, as provided herein, within 10 calendar days after the Bidder has received notice, that the Contract has been awarded, shall be just cause for the annulment of the award and the forfeiture of the Proposal guaranty.

**3-5 RETURN OF PROPOSAL GUARANTIES**

The City will retain the proposal guaranties of the first, second and third lowest responsible bidders until execution of the Contract. After complete execution of the Contract, all such retained guaranties will be returned to the respective bidders whose proposals they accompanied, except bidder's guaranties which have been forfeited. The proposal guaranties submitted by all other unsuccessful bidders will be returned after determination by the City of the first, second and third lowest responsible bidders.

## **SECTION 4 SCOPE OF WORK**

### **4-1 INTENT OF PLANS AND SPECIFICATIONS**

The intent of the Plans and Specifications is to prescribe the details for the construction and completion of the work which the Contractor agrees to perform in accordance with the terms of the Contract. Where the Plans and Specifications describe portions of the work in general terms, but not in complete detail, it is understood that only the best general practice is to prevail and that only materials and workmanship of the first quality are to be used. Unless otherwise specified, the Contractor shall furnish all labor, materials, tools, equipment, and incidentals, and do all the work involved in executing the Contract in a satisfactory and expert manner.

### **4-2 PROJECT SITE MAINTENANCE AND FINAL CLEANUP**

The Contractor shall maintain the project site in a neat and orderly condition during construction. At any time during construction, the City Engineer may direct the Contractor to perform a general cleanup of the site.

Before final inspection of the work, the Contractor shall clean the project site, material sites, and all ground occupied in connection with the work. All rubbish, excess materials, falsework, temporary structures, and equipment shall be disposed of properly or otherwise removed. All areas of the work shall -be left in a neat and presentable condition. Full compensation for final cleanup will be considered as included in the prices paid for the various Contract items of work and no separate payment will be made therefor.

Nothing herein, however, shall require the Contractor to remove warning, regulatory, and guide signs prior to formal acceptance by the City.

### **4-3 CHANGES**

The City reserves the right to make alterations, deviations, additions to or deletions from the Plans and Specifications. This includes the right to increase or decrease the quantity of any item or portion of the work or to delete any item or portion of the work, as determined by the City Engineer to be necessary or advisable. The City Engineer may also require extra work as deemed necessary for the proper completion or construction of the whole work contemplated.

Any such changes will be set forth in a Contract Change Order. It will specify, in addition to the work to be done in connection with the change made, adjustment of Contract time, if any, and the basis of compensation for such work. A Contract Change Order will not become effective until approved by the City Engineer.

Upon receipt of an approved Contract Change Order, the Contractor shall proceed with the ordered work. If ordered in writing by the City Engineer, the Contractor shall proceed with the work, so ordered, prior to actual receipt of an approved Contract Change Order therefor. In such cases, the



City Engineer will, as soon as practicable, issue an approved Contract Change Order for such work and the provisions in Section 4-3.1, "Procedure and Protest," shall be fully applicable to such subsequently issued Contract Change Order.

When the compensation for an item of work is subject to adjustment under the provisions of this Section, the Contractor shall, upon request, furnish the City Engineer with adequate detailed cost data for such item of work. If the Contractor requests an adjustment in compensation for an item of work as provided in Sections 4-3.2.1 or 4-3.2.2, such cost data shall be submitted with the request.

#### **4-3.1 PROCEDURE AND PROTEST**

A Contract Change Order approved by the City Engineer may be issued to the Contractor at any time. Should the Contractor disagree with any terms or conditions set forth in an approved Contract Change Order which has not been executed, the Contractor shall submit a written protest to the City Engineer. This written protest shall be submitted within 15 days after the receipt of such approved Contract Change Order. The protest shall state the points of disagreement, and, if possible, the Contract Specification references, quantities, and costs involved. If a written protest is not submitted, payment will be made as set forth in the approved Contract Change Order. Such payment shall constitute full compensation for all work included therein or required thereby. Such unprotested approved Contract Change Orders will be considered as executed Contract Change Orders as that term is used in these Specifications, and in particular in Sections 4-3.2 to 4-3.4, inclusive.

Where the protest concerning an approved Contract Change Order relates to compensation, the compensation payable for all work specified or required by said Contract Change Order to which such protest relates will be determined as provided in Sections 4-3.2 to 4-3.4, inclusive. The Contractor shall keep full and complete records of the cost of such work. He shall also permit the City Engineer to have such access thereto as may be necessary to assist in the determination of the compensation payable for such work.

Where the protest concerning an approved Contract Change Order relates to the adjustment of Contract time for the completion of the work, the time to be allowed therefor will be determined as provided in Section 8-7, "Liquidated Damages."

Proposed Contract Change Orders may be presented to the Contractor for consideration prior to approval by the City Engineer. If the Contractor signifies acceptance of the terms and conditions of such proposed Contract Change Order by executing such document, and if such Contract Change Order is approved by the City Engineer and issued to the Contractor, payment in accordance with the provisions as to compensation, therein set forth, shall constitute full compensation for all work included therein or required thereby. A Contract Change Order executed by the Contractor and approved by the City Engineer is an executed Contract Change Order as provided in these Specifications, especially Sections 4-3.2 to 4-3.4, inclusive. An approved Contract Change Order shall supersede a proposed, but unapproved, Contract Change Order covering the same work.

The City Engineer may provide for an adjustment of compensation as to a Contract item of work included in a Contract Change Order. This adjustment will be determined as provided in Sections 4-3.2 to 4-3.4, inclusive, if such item of work is eligible for an adjustment of compensation thereunder.



#### **4-3.2 INCREASED OR DECREASED QUANTITIES**

Increases or decreases in the quantity of a Contract item of work will be determined by comparing the total pay quantity of such item of work with the Engineer's Estimate therefor.

If the total pay quantity of any item of work required under the Contract varies from the Engineer's Estimate therefor by 25 percent or less, payment will be made for the quantity of work of said item performed at the Contract unit price therefor, unless eligible for adjustment pursuant to Section 4-3.3, "Changes in Character of Work."

If the total pay quantity of any item of work required under the Contract varies from the Engineer's Estimate therefor by more than 25 percent, in the absence of an executed Contract Change Order specifying the compensation to be paid, the compensation payable to the Contractor will be determined in accordance with Sections 4-3.2.1, 4-3.2.2, or 4-3.2.3, as the case may be.

##### **4-3.2.1 INCREASES OF MORE THAN 25 PERCENT**

Should the total pay quantity of any item of work required under the Contract exceed the Engineer's Estimate therefor by more than 25 percent, the work in excess of 125 percent of such estimate and not covered by an executed Contract Change Order specifying the compensation to be paid therefor will be paid for by adjusting the Contract unit price, as hereinafter provided, or at the option of the City Engineer, payment for the work involved in such excess will be made on the basis of force account as provided in Section 9-3.

Such adjustment of the Contract unit price will be the difference between the Contract unit price and the actual unit cost, which will be determined as hereinafter provided, of the total pay quantity of the item. If the costs applicable to such item of work include fixed costs, such fixed costs will be deemed to have been recovered by the Contractor by the payments made for 125 percent of the Engineer's Estimate of the quantity for such item, and in computing the actual unit cost, such fixed costs will be excluded. Subject to the above provisions, such actual unit cost will be determined by the City Engineer in the same manner as if the work were to be paid for on a force account basis as provided in Section 9-3, or such adjustment will be as agreed to by the Contractor and the City Engineer.

When the compensation payable for the number of units of an item of work performed in excess of 125 percent of the Engineer's Estimate is less than \$5,000 at the applicable Contract unit price, the City Engineer reserves the right to make no adjustment in said price, except that an adjustment will be made if requested in writing by the Contractor.

##### **4-3.2.2 DECREASES OF MORE THAN 25 PERCENT**

Should the total pay quantity of any item of work required under the Contract be less than 75 percent of the Engineer's Estimate therefor, an adjustment in compensation pursuant to this Section will not be made unless the Contractor so requests in writing. If the Contractor so requests, the quantity of said item performed, unless covered by an executed Contract Change Order specifying the compensation payable therefor, will be paid for by adjusting the Contract unit price as hereinafter provided. At the option of the City Engineer, payment for the quantity of the work of such item performed will be made on a force account basis as provided in Section 9-3, provided however, that

in no case shall the payment for such work be less than that which would be made at the Contract unit price.

Such adjustment of the Contract unit price will be the difference between the Contract unit price and the actual unit cost, which will be determined as hereinafter provided, of the total pay quantity of the item, including fixed costs. Such actual unit cost will be determined by the City Engineer in the same manner as if the work were to be paid for on a force account basis as provided in Section 9-3; or such adjustment will be as agreed to by the Contractor and the City Engineer.

The payment for the total pay quantity of any such item of work will in no case exceed the payment which would be made for the performance of 75 percent of the Engineer's Estimate of the quantity for such item at the original Contract unit price.

#### **4-3.2.3 ELIMINATED ITEMS**

Should any Contract item of the work be eliminated in its entirety, in the absence of an executed Contract change Order covering such elimination, payment will be made to the Contractor for actual costs incurred in connection with such eliminated Contract item, if incurred prior to the date of notification in writing by the City Engineer of such elimination.

If acceptable material is ordered by the Contractor for the eliminated item prior to the date of notification of such elimination by the City Engineer, and if orders for such material cannot be canceled, it will be paid for at the actual cost to the Contractor. In such case, the material paid for shall become the property of the City and the actual cost of any further handling will be paid for. If the material is returnable to the vendor and if the City Engineer so directs, the material shall be returned and the Contractor will be paid for the actual cost of charges made by the vendor for returning the material. Payment will be made for the actual cost of handling returned material.

Payment for the actual costs or charges as provided in this Section 4-3.2.3 will be computed in the same manner as if the work were to be paid for on a force account basis as provided in Section 9-3.

#### **4-3.3 CHANGES IN CHARACTER OF WORK**

If an ordered change in the Plans and Specifications materially changes the character of the work of a Contract item from that on which the Contractor based the bid price, and if the change increases or decreases the actual unit cost of such changed item as compared to the actual or estimated actual unit cost of performing the work of said item in accordance with the Plans and Specifications originally applicable thereto, in the absence of an executed Contract Change Order specifying the compensation payable, an adjustment in compensation therefor will be made in accordance with the following provisions of this section.

The basis of such adjustment in compensation will be the difference between the actual unit cost to perform the work of said item or portion thereof involved in the change as originally planned and the actual unit cost of performing the work of said item or portion thereof involved in the change, as changed. Actual unit costs will be determined by the City Engineer in the same manner as if the work were to be paid for on a force account basis as provided in Section 9-3, or such adjustment will be as agreed to by the Contractor and the City Engineer. Any such adjustment will apply only to the



portion of the work of said item actually changed in character. At the option of the City Engineer, the work of said item or portion of item which is changed in character will be paid for on a force account basis, as provided in Section 9-3.

If the compensation for an item of work is adjusted under this Section 4-3.3, the costs recognized in determining such adjustment shall be excluded from consideration in making an adjustment for such item of work under the provisions in Section 4-3.2, "Increased or Decreased Quantities."

Failure of the City Engineer to recognize a change in character of the work at the time the approved Contract Change Order is issued shall not be construed as relieving the Contractor of his duty and responsibility of filing a written protest within the 15-day limit as provided in Section 4-3.1, "Procedure and Protest."

#### **4-3.4 EXTRA WORK**

New and unforeseen work will be classed as extra work when determined by the City Engineer that such work is not covered by any of the various items for which there is a bid price or by combinations of such items. In the event portions of such work are determined by the City Engineer to be covered by some of the various items for which there is a bid price or combination of such items, the remaining portion of such work will be classed as extra work. Extra work also includes work specifically designated as extra work in the Plans and Specifications.

The Contractor shall do such extra work and furnish labor, material and equipment therefor upon receipt of an approved Contract Change Order or other written order of the City Engineer. In the absence of such approved Contract Change Order or other written order of the City Engineer, the Contractor shall not be entitled to payment for such extra work.

Payment for extra work required to be performed pursuant to the provisions in this Section 4- 3.4, in the absence of an executed Contract Change Order, will be made on a force account basis, as provided in Section 9-3, or as agreed to by the Contractor and the City Engineer.

#### **4-3.5 DIFFERING SITE CONDITIONS**

For any digging of trenches or other excavations that extend deeper than four feet below the surface, the following shall apply:

##### **4-3.5.1 NOTICE REQUIREMENT**

The Contractor shall promptly, and before the following conditions are disturbed, notify the City of Davis, in writing, of any:

##### **4-3.5.1.1 HAZARDOUS MATERIALS PER STATE LAW**

Material that the Contractor believes may be material that is hazardous waste, as defined in Section 25117 of the Health and Safety Code, that is required to be removed to a Class I, Class II, or Class III disposal site in accordance with provisions of existing law.

**4-3.5.1.2 DIFFERING PHYSICAL CONDITIONS**

Subsurface or latent physical conditions at the site differing from those indicated in the project documents.

**4-3.5.1.3 UNKNOWN PHYSICAL CONDITIONS**

Unknown physical conditions at the site of any unusual nature, different materially from those ordinarily encountered and generally recognized as inherent in work of the character provided for in the Contract.

**4-3.5.2 CITY INVESTIGATION AND ACTION**

The City of Davis shall promptly investigate the conditions, and if it finds that the conditions do materially so differ, or do involve hazardous waste, and cause a decrease or increase in the Contractor's cost of, or the time required for, performance of any part of the work, the City shall issue a Change Order under the procedures described in the Contract.

**4-3.5.3 DISPUTES**

In the event that a dispute arises between the City of Davis and the Contractor whether the conditions materially differ, or involve hazardous waste, or cause a decrease or increase in the Contractor's cost of, or time required for, performance of any part of the work, the Contractor shall not be excused from any scheduled completion date provided for by the Contract, but shall proceed with all work to be performed under the Contract. The Contractor shall retain any and all rights provided either by Contract or by law which pertain to the resolution of disputes and protests between the contracting parties.



## **SECTION 5 CONTROL OF WORK**

### **5-1 AUTHORITY OF CITY ENGINEER**

The City Engineer shall decide all questions as to the quality or acceptability of materials furnished and work performed, as to the manner of performance and rate of progress of the work, as to the interpretation of the Plans and Specifications, as to the acceptable fulfillment of the Contract on the part of the Contractor, and as to compensation. The City Engineer's decision shall be final and shall include the authority to enforce and make effective such decisions and orders which the Contractor fails to carry out promptly.

#### **5-1.1 FUNCTION OF PROJECT ENGINEER**

The Project Engineer is the design professional engaged as an independent contractor by the City of Davis to design the project and to advise the City Engineer, in all aspects of the construction phase of the project. The Project Engineer's functions include advice and assistance to the City Engineer in the correct interpretation and application of the Plans and Specifications. However, the City Engineer is the City's representative on the project, not the Project Engineer. The Project Engineer is not authorized to issue addenda, interpretations, or change orders, or in any other way to bind the City in discussions with the Contractor.

Copies of all correspondence relating to the proper performance of the Contract Documents sent from the Contractor to the City Engineer shall be delivered as well to the Project Engineer. The City Engineer then shall consult with the Project Engineer prior to responding to the Contractor's requests.

When discussions between the Contractor and the City Engineer occur either on the site or elsewhere, but the Project Engineer is not present, the City Engineer in all cases reserves the right to consult with and obtain the advice of the Project Engineer prior to issuing a final opinion or instruction, and to revise any opinions or instructions that may have been given prior to such consultation.

### **5-2 PLANS AND SHOP DRAWINGS**

The Contract Plans furnished consist of general drawings and show such details as are necessary to give a comprehensive idea of the construction contemplated. All authorized alterations affecting the requirements and information given on the Contract Plans shall be in writing.

The Plans shall be supplemented by such Shop Drawings prepared by the Contractor as are necessary to adequately control the work. No change shall be made by the Contractor in any Shop Drawing after they have been approved by the City Engineer.

When first submitted by the Contractor, each drawing shall be a good quality original accompanied by two duplicate originals or two prints. If approved without change or correction, three approved



copies of paper will be furnished to the Contractor. If extensive additions or corrections are required, the City Engineer will return one marked-up copy to the Contractor, together with the originals, for correction and resubmission. Approved originals will be retained by the City Engineer.

Prior to approval of Shop Drawings, payment will not be allowed nor shall material be furnished or fabricated, nor any work performed, for which such drawings are required.

It is expressly understood that approval of the Contractor's Shop Drawings shall not relieve the Contractor of any of his responsibility under the Contract for the successful completion of the work in conformity with the requirements of the Plans and Specifications. Such approval shall not operate to waive any of the requirements of the Plans and Specifications or relieve the Contractor of any obligation thereunder. Defective work, materials and equipment may be rejected regardless of any such approval.

Full compensation for furnishing all Shop Drawings shall be considered as included in the prices paid for the Contract items of work to which such drawings relate and no additional compensation will be allowed therefor.

### **5-2.1 TRENCH EXCAVATION SAFETY PLANS**

Attention is directed to Section 7-1.10, "Trench Safety." Excavation for any trench five feet or more in depth shall not begin until the Contractor has received approval, from the City Engineer, of the Contractor's detailed plan for worker protection from the hazards of caving ground during the excavation of such trench. Such plan shall be submitted at least five days before the Contractor intends to begin excavation for the trench and shall show the details of the design of shoring, bracing, sloping or other provisions to be made for worker protection during such excavation. No such plan shall allow the use of shoring, sloping or a protective system less effective than that required by the Construction Safety Orders of the Division of Industrial Safety.

If any submitted plans vary from the shoring or sloping requirements of the Construction Safety Orders of the Division of Industrial Safety, so as to provide a less effective protective system, the plans shall be prepared and signed by a Civil Engineer in the State of California and shall be submitted at least three weeks before the Contractor intends to begin excavation for the trench.

### **5-2.2 VARIATIONS FROM PLANS AND SPECIFICATIONS OR OTHER CONTRACT DOCUMENTS**

Any portion of the work which does not conform to the Plans, Specifications, or other Contract Documents, shall be clearly identified by the Contractor in a written letter proposing such change, which letter shall accompany any required Shop Drawing Submittals. The Contractor shall include any design calculations prepared by registered professionals in the letter proposing the change.

### **5-3 CONFORMITY WITH CONTRACT DOCUMENTS AND ALLOWABLE DEVIATIONS**

Work and materials shall conform to the lines, grades, cross-sections, dimensions and material requirements, including tolerances, shown on the Plans or indicated in the Specifications. Although

measurement, sampling and testing may be considered evidence of conformity, the City Engineer shall be the sole judge of whether the work or materials deviate from the Plans and Specifications. The City Engineer's decision shall be final as to any allowable deviations therefrom.

#### **5-4 COORDINATION AND INTERPRETATION OF PLANS, STANDARD SPECIFICATIONS, AND SPECIAL PROVISIONS**

These Standard Specifications, the Standard Plans, Project Plans, Special Provisions, Contract Change Orders, and all supplementary documents are essential parts of the Contract, and a requirement occurring in one is as binding as though occurring in all. They are intended to be complementary, and to describe and provide for a complete work.

Where conflicts exist between these Specifications, the Plans and/or any reference specifications, such conflicts shall be clarified according to the following order, the first ranked taking precedence over the lower ranked:

1. Special Provisions
2. Project Plans
3. Standard Plans
4. Standard Specifications
5. Referenced Specifications
6. Approved Shop Drawings

Should it appear that the work to be done or any of the matters relative thereto are not sufficiently detailed or explained in these Specifications, the Special Provisions, or the Plans, the Contractor shall apply to the City Engineer for such further explanations as may be necessary. The Contractor shall conform to any such further explanations as part of the Contract. In the event of any doubt or question arising respecting the true meaning of these Specifications, the Special Provisions or the Plans, reference shall be made to the City Engineer, whose decision thereon shall be final.

In the event of any discrepancy between any drawing and the figures written thereon, the figures shall be taken as correct. Detail drawings shall prevail over general drawings.

#### **5-5 ORDER OF WORK**

When required by the Special Provisions or Plans, the Contractor shall follow the sequence of operations as set forth therein.

Full compensation for conforming to such requirements will be considered as included in the prices paid for the various Contract items of work and no additional compensation will be allowed therefor.



**5-6 SUPERINTENDENCE**

The Contractor shall designate in writing before starting work, an authorized representative who shall have the authority to represent and act for the Contractor. The Contractor shall give the City Engineer 10 days written notice prior to changing an authorized representative. Said authorized representative shall be present at the site of the work at all times while work is actually in progress on the Contract. When work is not in progress and during periods when work is suspended, arrangements acceptable to the City Engineer shall be made for any emergency work which may be required.

Whenever the Contractor or an authorized representative is not present on any particular part of the work where it may be desired to give direction, orders will be given by the City Engineer, which shall be received and obeyed by the superintendent, foreman, or crew leader who may have charge of the particular work in reference to which the orders are given.

Any order given by the City Engineer, not otherwise required by the Specifications to be in writing, will on request of the Contractor, be given or confirmed by the City Engineer in writing.

**5-7 LINES AND GRADES**

The City Engineer will set such stakes or marks as determined to be necessary to establish the lines and grades required for the completion of the work, as specified in these Specifications, on the Plans and in the Special Provisions.

When such stakes or marks are required, the Contractor shall notify the City Engineer of such requirement in writing a reasonable length of time in advance of starting operations that require such stakes or marks. In no event, shall a notice of less than two working days be considered a reasonable length of time.

Stakes and marks set by the City Engineer shall be carefully preserved by the Contractor for the use of the City Engineer, as well as the Contractor. In case such stakes and marks are destroyed or damaged, they will be replaced at the City Engineer's earliest convenience. The Contractor will be charged for the cost of necessary replacement or restoration of stakes and marks which in the judgment of the City Engineer were carelessly or willfully destroyed or damaged by the Contractor's operations. This charge will be deducted from any money due or to become due the Contractor.

Three consecutive points set on the same slope shall be used together so that any variation from a straight grade can be detected. Any such variation shall be reported to the City Engineer. In the absence of such report, the Contractor shall be responsible for any error in the grade of the finished work.

Grades for underground conduits will be set at the surface of the ground. The Contractor shall transfer them to the bottom of the trench.

**5-8 INSPECTION**

The City Engineer shall at all times have access to the work during its construction, and shall be furnished with every reasonable facility for ascertaining that the materials and the workmanship are in accordance with the requirements and intentions of these Specifications, the Special Provisions,

and the Plans. All work done and all materials furnished shall be subject to the City Engineer's inspection.

The inspection of the work or materials shall not relieve the Contractor of any obligations to fulfill the Contract as prescribed. Work and materials not meeting such requirements shall be made good. Unsuitable work or materials may be rejected, notwithstanding that such work or materials have been previously included in a progress estimate.

Projects financed in whole or in part with State or Federal funds or other public funds shall be subject to inspection at all times by the State, Federal or other appropriate agency.

The Contractor shall give 24 hours notice when an inspection is required. This notice shall be given at the office of the City Engineer. Upon failure to give such notice, any work performed in the absence of the City Engineer shall be subject to rejection.

#### **5-8.1 HOURS OF WORK**

The Contractor shall schedule all work activities for regular working hours during weekdays, 7:00 am to 6:00 pm, Monday through Friday, with Saturdays, Sundays, and Legal Holidays being excluded. Inspection services will generally not be provided for work performed outside of these normal working hours. It is not expected that any work will be performed outside of these normal working hours. If the Contractor elects to work during non-normal work hours, then the Contractor shall arrange for inspection services during these hours.

#### **5-9 REMOVAL OF REJECTED AND UNAUTHORIZED WORK**

All work which has been rejected shall be remedied, or removed and replaced by the Contractor in an acceptable manner without compensation for such removal, replacement, or remedial work.

Any work done beyond the lines and grades shown on the Plans or as established by the City Engineer, or any extra work done without written authority will be considered as unauthorized work and no payment will be made therefor.

Upon order of the City Engineer, unauthorized work shall be remedied, removed, or replaced at the Contractor's expense.

Upon failure of the Contractor to comply promptly with any order of the City Engineer made under this Section 5-9, the City may cause rejected or unauthorized work to be remedied, removed, or replaced, and to deduct the costs from any money due or to become due the Contractor.

#### **5-10 EQUIPMENT AND PLANTS**

Only equipment and plants suitable to produce the quality of work and materials required will be permitted to operate on the project.

All vehicles used to haul materials over existing streets and highways shall be equipped with pneumatic tires and be appropriately licensed if necessary.



**5-11 CHARACTER OF WORKERS**

Any subcontractor or person employed by the Contractor appearing to the City Engineer to be incompetent or to act in a disorderly or improper manner, shall be discharged immediately on the order of the City Engineer, and such person shall not again be employed on the work.

**5-12 FINAL INSPECTION**

The City Engineer will not make the final inspection until the work provided and contemplated by the Contract has been completed, including the satisfactory performance of all functional and operation testing, and the final cleaning up performed.

**5-13 PUNCH LIST**

The City Engineer shall notify the Contractor in writing of any deficiencies to be remedied prior to final acceptance, by preparing a written list, commonly known in the industry as a punch list.

The Contractor shall remedy all items shown on the punch list.

The Contract shall not be modified or amended by the issuance of a punch list(s). It is provided solely for the benefit of the Contractor to enable determination of what items must be corrected before final acceptance will be recommended by the City Engineer.

**5-14 SUGGESTIONS TO CONTRACTOR ADOPTED AT OWN RISK**

Any plan or method of work suggested by the City Engineer to the Contractor, but not specified or required, if adopted or followed by the Contractor in whole or in part, shall be used at the risk and responsibility of the Contractor, and the City Engineer and the City shall assume no responsibility therefor.

**5-15 CONSTRUCTION ACCESS (TRUCK ROUTES)**

Truck and construction equipment traffic shall use the City's designated truck routes for access to the construction site. For projects that are not directly served by the designated truck routes, the City Engineer will specify the authorized route to be used from the truck route to the project site. The Contractor shall use the specified route to and from the site as the only access route for vehicles exceeding 3 tons GVW. The Contractor shall ensure that all project traffic including subcontractors and material suppliers comply with the specified route.

**5-16 REMOVAL, RELOCATION OR PROTECTION OF EXISTING UTILITIES**

In accordance with the provisions of Section 4215 of the California Government Code, any contract to which a public agency as defined in Section 4401 is a party, the public agency shall assume the responsibility, between the parties to the contract, for the timely removal, relocation, or protection of



existing main or trunkline utility facilities located on the site of any construction project that is a subject of the contract, if such utilities are not identified by the public agency in the plans and specifications made a part of the invitation for bids. The agency will compensate Contractor for the costs of locating, repairing damage not due to the failure of the Contractor to exercise reasonable care, and removing or relocating such utility facilities not indicated in the plans and specifications with reasonable accuracy, and for equipment on the project necessarily idled during such work.

The Contractor shall not be assessed liquidated damages for delay in completion of the project, when such delay was caused by the failure of the public agency or the owner of the utility to provide for removal or relocation of such utility facilities.

Nothing herein shall be deemed to require the public agency to indicate the presence of existing service laterals or appurtenances when the presence of such utilities on the site of the construction project can be inferred from the presence of other visible facilities, such as buildings, meter and junction boxes, on or adjacent to the site or construction; provided, however, nothing herein shall relieve the public agency from identifying main or trunklines in the plans and specifications.

If the Contractor while performing the Contract discovers utility facilities not identified by the public agency in the contract Documents it shall immediately notify the public agency and utility in writing.

The public utility, where they are the owner, shall have the sole discretion to perform such repairs or relocation work or permit the Contractor to do such repairs or relocation work at a reasonable price.

**SECTION 6  
CONTROL OF MATERIALS**

**6-1 SOURCE OF SUPPLY AND QUALITY OF MATERIALS**

The Contractor shall furnish all materials required to complete the work, except materials that are designated in the Special Provisions to be furnished by the City and materials furnished by the City in accordance with Section 9-3.1.2, "Materials."

Only materials conforming to the requirements of the Specifications shall be incorporated in the work.

The materials furnished and used shall be new except as may be provided elsewhere in these Specifications, on the Plans or in the Special Provisions. The materials shall be manufactured, handled and used in an expert manner to ensure completed work in accordance with the Plans and Specifications.

Materials to be used in the work will be subject to inspection and tests by the City Engineer or designated representative. The Contractor shall furnish without charge such samples as may be required. The Contractor shall furnish the City Engineer a list of his sources of materials and the locations at which such materials will be available for inspection. The City Engineer may inspect, sample or test materials at the source of supply or other locations. But such inspection, sampling or testing will not be undertaken until the City Engineer is assured by the Contractor of the cooperation and assistance of both the Contractor and the supplier of the material. The Contractor shall assure that the City Engineer or authorized representative has free access at all times to the material to be inspected, sampled or tested. It is understood that such inspections and tests if made at any point other than the point of incorporation in the work in no way shall be considered as a guaranty of acceptance of such material nor of continued acceptance of material presumed to be similar to that upon which inspections and tests have been made. Inspection and testing so performed shall not relieve the Contractor or suppliers of responsibility for quality control.

Manufacturers' warranties, guaranties, instruction sheets and parts lists, which are furnished with certain articles or materials incorporated in the work, shall be delivered to the City Engineer before acceptance of the Contract.

Reports and records of inspections made and tests performed, when available at the site of the work, may be examined by the Contractor.

**6-2 CITY FURNISHED MATERIALS**

Upon request of the Contractor, materials furnished by the City will be delivered to the contractor within a reasonable time at the points designated in the Special Provisions. They shall be hauled to the site of the work by the Contractor, at the Contractor's expense. The cost of handling and placing all materials, after they are delivered to the Contractor, shall be considered as included in the Contract prices for the items in connection with which they are used.



The Contractor will be held responsible for all delivered material, and deductions will be made from any money due the Contractor to make good any shortages and deficiencies, from any cause whatsoever, which may occur after such delivery.

### **6-3 SHORTAGE OF MATERIALS**

Articles or materials to be incorporated in the work shall be stored in such a manner as to ensure the preservation of their quality and fitness for the work, and to facilitate inspection.

### **6-4 DEFECTIVE MATERIALS**

All materials which the City Engineer has determined do not conform to the requirements of the Plans and Specifications will be rejected whether in place or not. They shall be removed immediately from the site of the work, unless otherwise permitted by the City Engineer. No rejected materials, the defects of which have been subsequently corrected, shall be used in the work, unless approval in writing has been given by the City Engineer. Upon failure of the Contractor to comply promptly with any order of the City Engineer made under the provisions in this Section 6-4, the City Engineer shall have authority to cause the removal and replacement of rejected material and to deduct the cost thereof from any money due or to become due the Contractor.

### **6-5 TRADE NAMES AND ALTERNATIVES**

For convenience in designation on the Plans or in the Specifications, certain articles or materials to be incorporated in the work are designated under a trade name or the name of a manufacturer and its catalogue information. The use of an alternative article or material which is of equal quality and of the required characteristics for the purpose intended will be permitted, subject to the following requirements:

The burden of proof as to the quality and suitability of alternatives shall be upon the Contractor who shall furnish all information necessary as required by the City Engineer. The City Engineer shall be the sole judge as to the quality and suitability of alternative articles or materials and shall make all final decisions. Whenever the Specifications permit the substitution of a similar or equivalent material or article, no tests or action relating to the approval of such substitute material will be made until the request for substitution is made in writing by the Contractor. Such written request shall be accompanied by complete data as to the equality of the material or article proposed. Such request shall be made in ample time to permit approval without delaying the work.

### **6-6 PLANT INSPECTION**

The City Engineer may inspect the production of material, or the manufacture of products at the source of supply. Plant inspection, however, will not be undertaken until the City Engineer is assured of the cooperation and assistance of both the Contractor and the material producer. The City Engineer or an authorized representative shall have free entry at all times to such parts of the plant as

concern the manufacture or production of the materials. Adequate facilities shall be furnished free of charge to make the necessary inspection. The City assumes no obligation to inspect materials at the source of supply.

### **6-7 CERTIFICATES OF COMPLIANCE**

A Certificate of Compliance shall be furnished prior to the use of any materials for which these Specifications or the Special Provisions require that such a certificate be furnished. In addition, when so authorized in these Specifications or in the Special Provisions, the City Engineer may permit the use of certain materials or assemblies prior to sampling and testing if accompanied by a Certificate of Compliance. The certificate shall be signed by the manufacturer of the material or the manufacturer of assembled materials and shall state that the materials involved comply in all respects with the requirements of the Specifications. A Certificate of Compliance shall be furnished with each lot of material delivered to the work and the lot so certified shall be clearly identified in the certificate.

All materials used on the basis of a Certificate of Compliance may be sampled and tested at any time. The fact that material is used on the basis of a Certificate of Compliance shall not relieve the Contractor of responsibility for incorporating material in the work which conforms to the requirements of the Plans and Specifications and any such material not conforming to such requirements will be subject to rejection whether in place or not. The City reserves the right to refuse to permit the use of material on the basis of a Certificate of Compliance.

The form of the Certificate of Compliance and its disposition shall be as directed by the City Engineer.

### **6-8 TESTING**

Unless otherwise specified, all tests shall be performed in accordance with the methods used by the California Department of Transportation and shall be made by the City Engineer or a designated representative.

The Department has developed methods for testing the quality of materials and work. These methods are identified by number and are referred to in the Specifications as California Test. Copies of individual California Tests are available at the Transportation Laboratory, Sacramento, California, and will be furnished to interested persons upon request.

Whenever a reference is made in the Specifications to a California Test by number, it shall mean the California Test in effect on the day the Notice to Contractors for the work is dated.

Whenever the Specifications provide an option between two or more tests, the City Engineer will determine the test to be used.

Whenever a reference is made in the Specifications to a specification, manual, or test designation either of the American Society for Testing and Materials, the American Association of State Highway and Transportation Officials, Federal Specifications, or any other recognized national organization, and the number or other identification representing the year of adoption or latest revision is omitted, it shall mean the specification, manual, or test designation in effect on the day the



Notice to Contractors for the work is dated. Whenever said specification, manual or test designation provides for test reports (such as certified mill test reports) from the manufacturer, copies of such reports, identified as to the lot of material, shall be furnished to the City Engineer. The manufacturer's test reports shall supplement the inspection, sampling and testing provisions in Section 6, "Control of Materials," and shall not constitute a waiver of the City's right to inspect. When material which cannot be identified with specific test reports is proposed for use, the City Engineer may select random samples from the lot for testing. Test specimens from the random samples, including those required for retest, shall be prepared in accordance with the referenced Specification and furnished and paid for by the Contractor. The number of such samples and test specimens shall be entirely at the discretion of the City Engineer.

When requested by the City Engineer, the Contractor shall furnish, without charge, samples of all materials entering into the work, and no material shall be used prior to approval by the City Engineer, except as provided in Section 6-7, "Certificates of Compliance."

The City will pay for all initial testing. In the event of failing tests, the Contractor shall pay the cost of subsequent retesting as necessary and as determined by the City Engineer.

## **6-9 CONSTRUCTION WATER**

When a new water system in any subdivision or other improvement project has been connected to the existing City water system, the water usage shall be subject to City regulation in accordance with the provisions of Section 7-3. All subsequent water use by the Contractor via the new improvements will be allowed subject to issuance of an approved Permit by Public Works. This condition applies whether or not the project has been accepted by the City.

### **6-9.1 CONSTRUCTION WATER ON CITY PROJECTS**

Water is available from the nearest fire hydrant or from the nearest blow off valve with permission of the Water Division Manager. There is no charge for the quantity used, however the City Contractor must obtain and possess a permit issued by the Public Works Department (1717 Fifth Street). The Contractor must truck or pipe the water to the construction site at their expense. The Contractor shall be responsible for maintaining any temporary piping in good condition such that there is minimal water waste. A suitable gate valve shall be attached to the fire hydrant or blow off valve used as the connection point.

## **6-10 SALVAGE**

All items labeled salvage on the Plans shall remain property of the City. Exercising due care, the Contractor shall remove, disassemble if appropriate, clean of loose dirt, haul, stock pile if so directed, and deliver all such items undamaged to the City's Corporation Yard (1717 Fifth Street) unless specifically directed otherwise in the Plans and Specifications.



## **SECTION 7 LEGAL RELATIONS AND RESPONSIBILITY**

### **7-1 LAWS TO BE OBSERVED**

The Contractor shall keep fully informed of all existing and future state and federal laws, and county and municipal ordinances and regulations which in any manner affect those engaged or employed in the work, or the materials used in the work, or which in any way affect the conduct of the work, and with all such orders and decrees of bodies or tribunals having any jurisdiction or authority over the same.

The Contractor shall at all times observe and comply with all existing laws, ordinances, regulations, orders, and decrees of bodies or tribunals having any jurisdictional authority over the work; and shall cause all agents and employees of the Contractor to do the same. The Contractor shall indemnify and hold harmless the City of Davis, its officers, agents, and employees from any and all claims or liabilities, including, but not limited to, fines and penalties, arising from or based on the violation of any such law, ordinance, regulation, order, or decree, whether by the Contractor or the Contractor's agents and employees. If any discrepancy or inconsistency is discovered in the Plans, Drawings, Specifications, or Contract for the work in relation to any such law, ordinance, regulation, order or decree, the Contractor shall forthwith report the same to the City Engineer in writing.

### **7-1.1 HOURS OF LABOR**

Eight hours labor constitutes a legal day's work. The Contractor shall forfeit, as a penalty to the City of Davis, \$25 for each worker employed in the execution of the Contract by the Contractor or any subcontractor for each calendar day during which such worker is required or permitted to work more than 8 hours in any one calendar day or more than 40 hours in any one calendar week in violation of the provisions of the Labor Code, and in particular, Section 1810 to Section 1815, thereof, inclusive. Work performed by employees of the Contractor in excess of 8 hours per day, and 40 hours during any one week, shall be permitted upon compensation for all hours worked in excess of 8 hours per day at not less than 1-1/2 times the basic rate of pay, as provided in said Section 1815.

### **7-1.2 PREVAILING WAGE**

The Contractor shall comply with Labor Code Sections 1774 and 1775. In accordance with said Section 1775, the Contractor shall forfeit as penalty to the City of Davis, \$50 for each calendar day or portion thereof, for each worker paid less than the prevailing rates. The prevailing rates are determined by the Director of Industrial Relations for such work or craft in which such worker is employed for any work done under the Contract in violation of the provisions of the Labor Code and in particular, Labor Code Sections 1770 to 1780, inclusive. In addition to said penalty and pursuant to said Section 1775, the difference between such prevailing wage rates and the amount paid to each worker for each calendar day or portion thereof for which each worker was paid less than the prevailing wage rate shall be paid to each worker by the Contractor.

Pursuant to the provisions of Section 1773 of the Labor Code of the State of California, the City has obtained the general prevailing rate of wages (which rate includes employer payments for health and welfare, pension, vacation, travel time, and subsistence pay as provided for in Section 1773.1 of said Code, apprenticeship or other training programs authorized by Section 3093 of said Code, and similar purposes) applicable to the work to be done, for straight time, overtime, Saturday, Sunday and holiday work. The holiday wage rate listed shall be applicable to all holidays recognized in the collective bargaining agreement of the particular craft, classification or type of worker concerned. These wage rates are set forth in the Department of Transportation publication entitled General Prevailing Wage Rates, which is a part of the Contract.

Pursuant to Section 1773.2 of the Labor Code, general prevailing wage rates set forth in the Department of Transportation publication entitled General Prevailing Wage Rates, which is a part of the Contract, shall be posted by the Contractor at a prominent place at the site of the work. The wage rates at the time of the bid advertisement date of this project will remain in effect for the life of this project.

The City will not recognize any claim for additional compensation because of the payment by the Contractor of any wage rate in excess of the prevailing wage rate set forth in the Contract. The possibility of wage increases is one of the elements to be considered by the Contractor in determining a bid, and will not under any circumstances be considered as the basis of a claim against the City on the Contract.

### **7-1.3 PAYROLL RECORDS**

The Contractor's attention is directed to the provisions of Labor Code Sections 1776 and 1812. The Contractor shall be responsible for compliance by subcontractors.

A copy of all payrolls shall be submitted weekly to the City Engineer, upon request. Payrolls shall contain each employee's full name, address, social security number, correct classification, rate of pay, daily and weekly number of hours worked, itemized deductions and actual wages paid. They shall also indicate apprentices and ratio of apprentices to journeymen. The employee's address and social security number need only appear on the first payroll on which the employee's name appears. The payroll shall be accompanied by a "Statement of Compliance" signed by the employer or designated agent indicating that the payrolls are correct and complete and that the wage rates contained therein are not less than those required by the Contract. The "Statement of Compliance" shall be on standard forms furnished by the Contractor. The Contractor shall be responsible for the submission of copies of payrolls of all subcontractors.

The penalties specified in Section 1813 of the Labor Code for noncompliance with the provisions of Section 1811 may be deducted from any money due or which may become due to the Contractor.

The Contractor shall forfeit to the City of Davis \$25 per day, per worker, where such worker is required or permitted to work eight hours in anyone calendar day and/or 40 hours in any one calendar week in violation of the provisions of California Labor Code Section 1810, et seq.

The Contractor and each subcontractor shall preserve their payroll records for a period of 3 years from the date of completion of the Contract.



#### **7-1.4 LABOR NONDISCRIMINATION**

Attention is directed to Section 1735 of the Labor Code, which reads as follows:

"A contractor shall not discriminate in the employment of persons upon public works on any basis listed in subdivision (a) of Section 12940 of the Government Code, as those bases are defined in Sections 12926 and 12926.1 of the Government Code, except as otherwise provided in Section 12940 of the Government Code. Every contractor for public works who violates this section is subject to all the penalties imposed for a violation of this chapter. "

Attention is also directed to the requirements of the California Fair Employment and Housing Act (Government Code Sections 12900 et. seq.), to the regulations promulgated by the Fair Employment and Housing Commission to implement said Act, and to the nondiscrimination, affirmative action and equal employment opportunity requirements in the Special Provisions.

#### **7-1.5 CITY OF DAVIS FAIR EMPLOYMENT PRACTICES**

##### **7-1.5.1 REQUIREMENT**

In the performance of this Contract, the Contractor will not discriminate against any employee or applicant for employment because of race, creed, color, national origin, ancestry, sex, age, religion, sexual preference, marital status, physical handicap, or medical condition; the Contractor will take affirmative action to ensure that applicants are employed, and that employees are treated equally during employment, without regard to their race, creed, color, national origin, ancestry, sex, age, religion, sexual preference, marital status, physical handicap, or medical condition. Such action shall include, but not be limited to, the following: employment, upgrading, demotion or transfer; recruitment or recruitment advertising; layoff or termination; rates of pay or other forms of compensation; and selection of training, including apprenticeship. The Contractor shall post in conspicuous places, available to employees and applicants for employment, notices to be provided by the City of Davis setting forth the provisions of this Fair Employment Practices section.

##### **7-1.5.2 ACCESS TO RECORDS**

The Contractor will permit access to records of employment, employment advertisements, application forms, and other pertinent data and records by the City of Davis Human Relations Commission, or any other agency of the State of California designated by the awarding authority, for the purpose of investigation to ascertain compliance with the Fair Employment Practices section of this Contract.

##### **7-1.5.3 REMEDIES FOR VIOLATION**

Remedies for willful violation are as follows:

- A. The City of Davis may determine a willful violation of the Fair Employment Practices provision to have occurred upon receipt of a final judgment having that effect from a court in an action to which Contractor was a party, or upon receipt of a written notice from the Davis Human Relations Commission, that it has investigated and determined that the Contractor has violated the Fair Employment Practices Act and has issued an order, under Government Code Section 12970, which has become final, or obtained an order for relief under Government Code Section 12974.
- B. For willful violation of this Fair Employment Practices provision, the City of Davis shall have the right to terminate this Contract either in whole, or in pan, and any loss or damage sustained by the City of Davis in securing the goods, or services hereunder shall be borne and paid for by the Contractor and by the surety under the Performance Bond, if any, and the City of Davis may deduct from any money due, or that thereafter may come due to the Contractor, the difference between the price named in the Contract and the actual cost thereof to the City of Davis.

#### **7-1.6 EQUAL EMPLOYMENT OPPORTUNITY REQUIREMENTS**

The City of Davis is an equal opportunity employer. It is the policy of the City that minority business enterprise (MBE) and women business enterprise (WBE) shall have the maximum opportunity to participate in the performance of construction contracts. If specific MBE/WBE goals are not stated in the Special Provisions, the Contractor is still expected to ensure that MBE/WBEs have the maximum opportunity to participate in the performance of the contract. Therefore the Contractor shall take all necessary and reasonable steps to ensure participation of MBE/WBEs. The Contractor shall not discriminate on the basis of race, color, national origin, sex, or sexual orientation. Failure to carry out these requirements shall constitute a breach of contract and may result in the termination of the contract.

#### **7-1.7 APPRENTICES**

Attention is directed to Sections 1777.5, 1777.6 and 1777.7 of the California Labor Code and Title 8, California Code of Regulations, Section 200 et seq. To ensure compliance and complete understanding of the law regarding apprentices, and specifically the required ratio thereunder, each Contractor or subcontractor shall, where some question exists, contact the Division of Apprenticeship Standards, 455 Golden Gate Avenue, San Francisco, California, or one of its branch offices prior to commencement of work on the public works Contract. Responsibility for compliance with this Section lies with the Prime Contractor. It is State policy to encourage the employment and training of apprentices on public works contracts as may be permitted under local apprenticeship standards.

#### **7-1.8 WORKERS' COMPENSATION**

Pursuant to the requirements of Section 1860 of the Labor Code, the Contractor will be required to secure the payment of workers' compensation to his employees in accordance with the provisions of Section 3700 of the Labor Code. Prior to the commencement of work, the Contractor shall sign and file with the City Engineer a certification in the following form:



"I am aware of the provisions of Section 3700 of the Labor Code which requires every employer to be insured against liability for worker's compensation or to undertake self-insurance in accordance with the provisions of said Code and I will comply with such provisions before commencing the performance of the work of this Contract."

Said certification is included in the Contract, and signature and return of the Contract as provided in Section 3-3, "Execution of Contract," shall constitute signing and filing of the said certificate.

The Contractor shall post, and cause all subcontractors to post, in a conspicuous place on the project site, a statement as required by Labor Code Section 3550, stating the name of the Workers' Compensation insurance carrier or that the employer is self-insured, and who is responsible for claims adjustment. The notice shall also include advice as to the injured employee's right to receive medical care, to select or change the treating physician pursuant to the provisions of Labor Code Section 4600, and the right to receive temporary disability indemnity, permanent disability indemnity, vocational rehabilitation services, and death benefits, as appropriate.

The Contractor and all subcontractors shall also give every new employee, either at the time the employee is hired or by the end of the first pay period, written notice of the information contained in Labor Code Section 3550.

### **7-1.9 CONTRACTOR'S LICENSING LAWS**

Attention is directed to the provisions of Chapter 9 of Division 3 of the Business and Professions Code concerning the licensing of contractors. All bidders and contractors shall be licensed in accordance with the laws of this State and any bidder or contractor not so licensed is subject to the penalties imposed by such laws.

### **7-1.10 TRENCH SAFETY**

The Contractor shall comply with all applicable laws, ordinances and regulations relating to trench safety. The Contractor shall at all times maintain suitable barricades, warning devices, trench shoring, bracing, and covers and other protective measures as deemed appropriate by the City Engineer, which measures shall provide only the highest suitable level of protection to all workers, inspectors and the general public. Attention is directed to the provisions of Section 7-6, "Public Convenience," Section 7-7, "Public Safety," and Section 7-9, "Preservation of Property." Attention is directed to the provisions of Section 6705 of the Labor Code concerning trench excavation safety plans and to Section 5-2.1, "Trench Excavation Safety Plans."

### **7-1.11 SOUND CONTROL REQUIREMENTS**

The Contractor shall comply with all local sound control and noise level rules, regulations and ordinances which apply to any work performed pursuant to the Contract.



Each internal combustion engine, used for any purpose on the job or related to the job, shall be equipped with a muffler of a type recommended by the manufacturer. No internal combustion engine shall be operated on the project without said muffler.

## **7-2 PAYMENT OF TAXES**

The Contract prices paid for the work shall include full compensation for all taxes which the Contractor is required to pay, whether imposed by Federal, State or local government, including, without being limited to, State Sales Tax and Federal Excise Tax.

## **7-3 PERMITS AND LICENSES**

The Contractor shall procure all permits and licenses, pay all charges and fees, and give all notices necessary and incident to the due and lawful prosecution of the work.

The Prime Contractor shall obtain a City of Davis Business License. The dollar amount claimed for "gross receipts" shall be the dollar amount awarded to the Contractor.

An Encroachment Permit, issued by the Department of Public Works, is required for the use of City-supplied water, including water drawn from construction areas or subdivisions under construction. All use of City-supplied water shall be regulated by the City Engineer. The Permittee shall abide by the Water Use Permit requirements in effect at the time of issuance. The use of City water may be revoked by the City Engineer at any time, without prior notice.

In the event that the City has obtained permits, licenses or other authorizations, applicable to the work, the Contractor shall comply with the provisions of said permits, licenses and other authorizations.

## **7-4 PATENTS**

The Contractor shall assume all costs arising from the use of patented materials, equipment, devices or processes used on or incorporated in the work, and agrees to indemnify and save harmless the City of Davis, the City Council, the City Engineer, and their duly authorized representatives, from all suits at law, or actions of every nature for, or on account of the use of any patented materials, equipment, devices, or processes.

## **7-5 SAFETY AND HEALTH PROVISIONS**

The Contractor shall conform to all applicable occupational safety and health standards, rules, regulations and orders established by the State of California. Local emergency phone numbers (police, fire, ambulance, hospital) shall be posted on the job site in a conspicuous location.

### **7-5.1 JOBSITE TOILET FACILITIES**

Fixed or portable chemical toilets shall be provided for the use of the employees. Toilets at the site shall conform to the OSHA Safety and Health Standards for Construction.

**7-6 PUBLIC CONVENIENCE**

This Section 7-6 defines the Contractor's responsibility with regard to convenience of the public and public traffic in connection with construction operations.

Attention is directed to Section 7-7, "Public Safety" for provisions relating to the Contractor's responsibility for the safety of the public. The requirements in said Section 7-7 are in addition to the requirements of this Section 7-6 and the Contractor will not be relieved of any responsibilities as set forth in said Section 7-7 by reason of conformance with any of the provisions in this Section 7-6.

In the event of a suspension of the work, attention is directed to Section 8-5, "Temporary Suspension of Work."

The Contractor shall conduct operations so as to offer the least possible obstruction and inconvenience to the public. The Contractor shall have under construction no greater length or amount of work than can be prosecuted properly with due regard to the rights of the public.

Unless otherwise provided in the Special Provisions, all public traffic shall be permitted to pass through the work with as little inconvenience and delay as possible. Where possible, such traffic shall be routed on new or existing paved surfaces.

Spillage resulting from hauling operations along or across any public traveled way shall be removed immediately by the Contractor at the Contractor's expense.

Existing traffic signal and street lighting systems shall be kept in operation for the benefit of the traveling public during progress of the work. Other forces will continue routine maintenance of existing systems.

Construction operations shall be conducted in such a manner so as to cause as little inconvenience as possible to abutting property owners. Convenient access to driveways, houses, and buildings along the line of work shall be maintained. When the abutting property owner's access across the right-of-way line is to be eliminated, or to be replaced under the Contract by other access facilities, the existing access shall not be closed until the replacement access facilities are usable.

The Contractor is responsible for providing 24-hour per day dust control. Dust control measures shall be applied as necessary, or as directed by the City Engineer to prevent the transport off-site of any dust or other airborne nuisance.

Additional water or dust palliative shall be applied if ordered by the City Engineer for the alleviation or prevention of dust nuisance. No separate payment will be made for any work performed or material used to control dust resulting from the Contractor's performance of the work, or caused by public traffic: either inside or outside the right-of-way. Full compensation for such dust control will be considered as included in the prices paid for the various items of work involved.

In order to expedite the passage of public traffic through or around the work and where ordered by the City Engineer, the Contractor shall install and maintain in good condition, signs, lights, flares,



temporary railing (Type K), barricades, and other facilities for the sole convenience and direction of public traffic. Also, where directed by the City Engineer, the Contractor shall furnish competent flaggers whose sole duties shall consist of directing the movement of public traffic through or around the work.

Should the Contractor fail to install or maintain traffic control devices required by the City Engineer or the Special Provisions, the City Engineer may cause such installation or maintenance by other forces and shall deduct the cost thereof from money due or to become due the Contractor under the Contract.

Whenever a section of surfacing or pavement has been completed, the Contractor shall open it to use by public traffic if the City Engineer so orders or may open it to use by public traffic if the City Engineer so consents. In either case, the Contractor will not be allowed any compensation due to any delay, hindrance, or inconvenience to operations caused by such public traffic, but will thereupon be relieved of responsibility for damage to the work caused by public traffic, within the limits of such use. The Contractor will not be relieved of cleanup and finishing operations, or of any other responsibility under the Contract.

Except as otherwise provided in this Section 7-6 or in the Special Provisions, full compensation for conforming to the requirements in this Section 7-6 and in the Special Provisions shall be considered as included in the prices paid for the various Contract items of work and no additional compensation will be allowed therefor.

## **7-7 PUBLIC SAFETY**

It is the Contractor's responsibility to provide for the safety of traffic and the public during construction.

Attention is directed to Section 7-10, "Responsibility for Damage." Attention is also directed to Section 7-6, "Public Convenience," for provisions relating to the Contractor's responsibility for providing for the convenience of the public in connection with operations required to complete work under the Contract.

Whenever the Contractor's operations create a condition hazardous to traffic or to the public, the Contractor shall furnish, erect and maintain such fences, temporary railing (Type K), barricades, lights, signs and other devices and take such other protective measures as are necessary to prevent accidents or damage or injury to the public. The Contractor shall also furnish such flaggers as are necessary to give adequate warning to traffic or to the public of any dangerous conditions to be encountered. All such measures shall be performed at the Contractor's sole expense and without cost to the City.

Signs, lights, flags, and other warning and safety devices and their use shall conform to the requirements set forth in the current "California Manual on Uniform Traffic Control Devices," published by the California Department of Transportation.

No material or equipment shall be stored where it will interfere with the free and safe passage of public traffic. At the end of each day's work and at other times when construction operations are

suspended for any reason, the Contractor shall remove all equipment and other obstructions from that portion of the roadway for use by public traffic.

Should the Contractor appear to be neglectful or negligent in furnishing warning devices and taking protective measures as above provided, the City Engineer may direct attention to the existence of a hazard, and the necessary warning devices shall be furnished and installed, and protective measures taken by the Contractor at the Contractor's expense. Should the City Engineer point out the inadequacy of warning devices and protective measures, such action on the part of the City Engineer shall not relieve the Contractor from responsibility for public safety or abrogate obligation to furnish and pay for these devices and measures.

Except as otherwise provided in the Special Provisions, full compensation for conforming to all of the provisions in this Section 7-7 and in the Special Provisions shall be considered as included in the prices paid for the various Contract items of work and no additional compensation will be allowed therefor.

#### **7-8 USE OF EXPLOSIVES**

The use of explosives is not allowed, unless otherwise provided in the Special Provisions.

#### **7-9 PRESERVATION OF PROPERTY**

Attention is directed to Section 7-10, "Responsibility for Damage." Due care shall be exercised to avoid injury to existing highway improvements or facilities, utility facilities, adjacent property, and roadside trees, shrubs, and other plants that are not to be removed.

Trees, shrubs, and other plants that are not to be removed, and pole lines, fences, signs, markers and monuments, buildings and structures, conduits, pipelines under or above ground, sewer and water lines, all street facilities, and any other improvements or facilities within or adjacent to the work shall be protected from injury or damage. If ordered by the City Engineer, the Contractor shall provide and install suitable safeguards, approved by the City Engineer, to protect such objects from injury or damage. If such objects are injured or damaged by reason of the Contractor's operations, they shall be replaced or restored at the Contractor's expense. The facilities shall be replaced or restored to a condition as good as when the Contractor entered upon the work, or as good as required by the Specifications accompanying the Contract, if any such objects are a part of the work being performed under the Contract. The City Engineer may make or cause to be made such temporary repairs as are necessary to restore to service any damaged highway facility. The cost of such repairs shall be borne by the Contractor and may be deducted from any money due or to become due to the Contractor under the Contract.

Attention is directed to the possible existence of underground main or trunk line facilities not indicated on the plans or in the special Provisions and to the possibility that underground main or trunk lines may be in a location different from that which is indicated on the plans or in the Special Provisions. The Contractor shall ascertain the exact location of underground main or trunk lines whose presence is indicated on the plans or in the Special Provisions, and the location of their service laterals or other appurtenances, and of existing service laterals or appurtenances of any other underground facilities which can be inferred from the presence of visible facilities such as buildings,



meters and junction boxes. This determination shall be made prior to doing work that may damage any of such facilities or interfere with their service.

The Contractor shall immediately notify the City Engineer of any delays to operations which are a direct result of underground main or trunk line facilities which were not indicated on the plans or in the Special Provisions or were located in a position substantially different from that indicated on the plans or in the Special Provisions. Such delays will be considered right-of-way delays within the meaning of Section 8-9, "Right-Of-Way Delays," and compensation for such delay will be determined in accordance with said Section 8-9. The Contractor shall be entitled to no other compensation for any such delay.

Except as provided above, full compensation for furnishing all labor, materials, tools, equipment, and incidentals, and for doing all the work involved in protecting or repairing property as specified in this Section 7-9, shall be considered as included in the prices paid for the various Contract items of work and no additional compensation will be allowed therefor.

#### **7-10 RESPONSIBILITY FOR DAMAGE**

The Contractor shall defend, indemnify and save harmless the City and all its officers, agents, and employees from any and all claims, demands, damages, costs, expenses or liability occasioned by the performance or attempted performance of the provisions hereof or in any way arising out of the Contract, including, but not limited to, inverse condemnation, equitable relief, or any wrongful act, or any negligent act or omission to act on the part of the Contractor or any of its agents, employees, independent contractors, or subcontractors; provided, further, that the foregoing shall apply to any wrongful acts, or any actively or passively negligent acts or omissions to act, committed jointly or concurrently by the Contractor, the Contractor's agents, employees or independent contractors or subcontractors, and the City, its agents, employees, or independent contractors.

Such indemnity obligation expressly extends to and includes any and all claims, demands, damages, costs, expenses or liability occasioned as a result of damages to adjacent property caused by the conduct of the work.

Such indemnity obligation expressly extends to and includes any and all claims, demands, damages, costs, expenses or liability occasioned as a result of the violation by the Contractor, the Contractor's agents, employees, or independent contractors or subcontractors, of any provisions of federal or state law, including, but not limited to, fines or penalties.

Such indemnity obligation also expressly extends to and includes any claims, demands, damages, costs, expenses or liability occasioned by injury to or death of any person, or any property damage to property owned by any person while on or about the premises of the work or as a result of the work, whether such persons are on or about the premises by right or not, whenever the work is alleged to have been a contributing cause in any degree whatsoever.

Nothing contained in the foregoing indemnity provisions shall be construed to require the Contractor to indemnify the City in contravention of Section 2782 of the Civil Code.

## **7-11 INSURANCE REQUIREMENTS**

The Contractor shall obtain, at the Contractor's sole cost and expense, all insurance required herein. Certificate of Insurance and Endorsements shall be delivered to the City prior to execution of the Contract and before any work commences.

Certificate of Insurance and Endorsements shall be submitted on the forms supplied by the City of Davis per Section 7-11.6. A Waiver of Subrogation is required on all City projects for the Contractor's Worker's Compensation Insurance.

The Contractor shall maintain in full force and effect for the duration of this Contract, liability insurance on all of its operations with an insurance carrier satisfactory to the City, insuring without limitation, against claims arising from bodily and personal injury, including death resulting from any act or occurrence arising out of the performance of this Contract, including acts involving vehicles.

The City reserves the right to require complete, certified copies of all required insurance policies, at any time.

### **7-11.1 MINIMUM SCOPE OF INSURANCE**

The coverage shall at least be as broad as:

- A. Insurance Services Office form Number GL 0002 (Ed. 1173) covering Comprehensive General Liability and Insurance Services Office form GL 0404 covering Broad Form Comprehensive General Liability; or Insurance Services Office Commercial General Liability coverage ("occurrence" form CG 00(1).
- B. Insurance Services Office form Number CA 0001 (Ed. 1187) covering Automobile Liability, Code 1 "any auto."
- C. Workers' Compensation insurance as required by the Labor Code of the State of California and Employers Liability insurance.

### **7-11.2 MINIMUM LIMITS OF INSURANCE**

The Contractor shall maintain limits no less than:

- A. Comprehensive General Liability: \$1,000,000 combined single limit per occurrence for bodily injury, personal injury and property damage.
- B. Automobile Liability: \$1,000,000 combined single limit per accident for bodily injury and property damage.
- C. Workers' Compensation and Employers Liability: Workers' compensation limits as required by the Labor Code of the State of California and Employers Liability limits of \$1,000,000 per accident.



### **7-11.3 DEDUCTIBLES AND SELF-INSURED RETENTIONS**

Any deductibles or self-insured retentions must be declared to and approved by the City. At the option of the City either: the insurer shall reduce or eliminate such deductibles or self-insured retentions as respects the City, its officials and employees; or the Contractor shall procure a bond guaranteeing payment of losses and related investigations, claim administration and defense expenses.

### **7-11.4 OTHER INSURANCE PROVISIONS**

The policies are to contain, or be endorsed to contain, the following provisions:

#### **7-11.4.1 GENERAL LIABILITY AND AUTOMOBILE LIABILITY COVERAGE**

The City, its officers, officials, employees and volunteers are to be covered as insureds as respects: liability arising out of activities performed by or on behalf of the Contractor; products and completed operations of the Contractor; premises owned, leased or used by the Contractor; or automobiles owned, leased, hired or borrowed by the Contractor. The coverage shall contain no special limitations on the scope of protection afforded to the City, its officers, officials, employees or volunteers.

The Contractor's insurance coverage shall be primary insurance as respects the City, its officers, official, employees and volunteers. Any insurance or self-insurance maintained by the City, its officials, employees or volunteers shall be excess of the Contractor's insurance and shall not contribute with it.

Any failure to comply with reporting provisions of the policies shall not affect coverage provided to the City, its officers, officials, employees or volunteers.

The Contractor's insurance shall apply separately to each insured against whom claim is made or suit is brought, except with respect to the limits of the insurer's liability.

#### **7-11.4.2 WORKERS' COMPENSATION AND EMPLOYERS LIABILITY COVERAGE**

The insurer shall agree to waive all rights of subrogation against the City, its officers, officials, employees and volunteers for losses arising from work performed by the Contractor for the City.

#### **7-11.4.3 ALL COVERAGES**

Each insurance policy required by this clause shall be endorsed to state that coverage shall not be suspended, voided, canceled by either party, reduced in coverage or in limits except, after 30 days prior written notice by certified mail, return receipt requested, has been given to the City.

### **7-11.5 ACCEPTABILITY OF INSURERS**

Insurance is to be placed with insurers with a Bests' rating of no less than A:VII.

**7-11.6 VERIFICATION OF COVERAGE**

The Contractor shall furnish to the City certificates of insurance and original endorsements affecting coverage required by this clause. The Certificates and endorsements for each insurance policy are to be signed by a person authorized by that insurer to bind coverage on its behalf. The certificates and endorsements are to be on forms provided by the City and are to be received and approved by the City before work commences.

**7-11.7 SUBCONTRACTORS**

The Contractor shall include all subcontractors as insureds under its policies or shall furnish separate certificates and endorsements for each subcontractor. All coverages for subcontractors shall be subject to all the requirements stated herein.

**7-12 LEGAL ACTIONS AGAINST THE CITY**

In the event litigation is brought against the City concerning the compliance of the City with State or Federal laws, rules or regulations, or other applicable rules, regulations or ordinances, the provisions of this Section shall apply.

- A. If, pursuant to court order, the City prohibits the Contractor from performing all or any portion of the work, the delay will be considered a delay within the meaning of Section 8-9, "Right-Of-Way Delays," unless the Contract is terminated as hereinafter provided.
- B. If, pursuant to court order (other than an order to show cause) the City is prohibited from requiring the Contractor to perform all or any portion of the work, the City may, if it so elects, eliminate the enjoined work pursuant to Section 4-3, "Changes," or terminate the Contract.
- C. If the final judgment in the action prohibits the City from requiring the Contractor to perform all or any portion of the work, the City will either eliminate the enjoined work pursuant to Section 4-3, "Changes," or terminate the Contract.
- D. If the Contract is to be terminated, the termination and the determination of the payable to the Contractor shall be governed by the provisions of Section 8-10, "Termination of Contract."

**7-13 DISPOSAL OF MATERIAL**

The Contractor shall make arrangements for disposal of materials, and pay all costs involved.

Prior to disposal of any materials on private property, the Contractor shall submit to the City Engineer satisfactory evidence of having entered into agreements with the property owners of the disposal site and of having obtained any permits, licenses and environmental clearances that may be required.



The Contractor shall obtain written authorization from the property owner on whose property the disposal is to be made. The Contractor shall also file with the City Engineer said authorization or a copy thereof together with a written release from the property owner absolving the City of Davis from any and all responsibility in connection with the disposal of material on said property.

Before acceptance of the Contract, the City Engineer may require the Contractor to submit written evidence that the owner of the disposal site is satisfied that the Contractor has complied with the provisions of the agreement between the owner and the Contractor.

Full compensation for all costs involved in disposing of materials as specified in this Section 7-13, including all costs of hauling, shall be considered as included in the price paid for the Contract item of work involving such materials and no additional compensation will be allowed therefor.

#### **7-14 COOPERATION**

Should construction be under way by other forces or by other contractors within or adjacent to the limits of the work specified or should work of any other nature be under way by other forces within or adjacent to said limits, the Contractor shall cooperate with all such other contractors or other forces to the end that any delay or hindrance to their work will be avoided. The right is reserved to perform other or additional work at or near the site (including material sources) at any time, by the use of other forces.

#### **7-15 RELIEF FROM MAINTENANCE AND RESPONSIBILITY**

Upon the request of the Contractor, the City Engineer may relieve the Contractor of the duty of maintaining and protecting certain portions of the work which have been completed in all respects, in accordance with the requirements of the Contract, and to the satisfaction of the City Engineer, and thereafter except with consent, the Contractor will not be required to do further work thereon. In addition, such action by the City Engineer will relieve the Contractor of responsibility for injury or damage to said completed portions of the work resulting from use by public traffic or from the action of the elements or from any other cause but not from injury or damage resulting from the Contractor's own operations or negligence. However, nothing in this Section 7-15 providing for relief from maintenance and responsibility will be construed as relieving the Contractor of full responsibility for making good defective work or materials found at any time before the formal written acceptance of the entire Contract by the City.

#### **7-16 CONTRACTOR'S RESPONSIBILITY FOR THE WORK MATERIALS**

Until the acceptance of the Contract, the Contractor shall have the charge and care of the work and of the materials to be used therein (including materials for which partial payment has been made, or materials which have been furnished by the City), and shall bear the risk of injury, loss or damage to any part thereof by the action of the elements or from any other cause, whether arising from the execution or from the non-execution of the work, except as provided in Sections 7-6, "Public Convenience," and 7-15, "Relief from Maintenance and Responsibility."

The Contractor shall rebuild, repair, restore, and make good all injuries, losses, or damages to any portion of the work or the materials occasioned by any cause before its completion and acceptance and shall bear the expense thereof. Where necessary to protect the work or materials from damage, the Contractor shall provide suitable drainage of any roadway and erect such temporary structures as are necessary to protect the work or materials from damage at no expense to the City. The suspension of the work from any cause whatever shall not relieve the Contractor of responsibility for the work and materials as herein specified.

#### **7-17 ACCEPTANCE OF CONTRACT**

When the City Engineer has made the final inspection as provided in Section 5-12, "Final Inspection," and determines that the Contract work has been completed in all respects in accordance with the Plans and Specifications, the City Engineer will recommend that the City formally accept the Contract. Immediately upon and after such acceptance by the City, the Contractor will be relieved of the duty of maintaining and protecting the work as a whole, and will not be required to perform any further work thereon. The Contractor shall also be relieved of responsibility for injury to persons or property or damage to the work which occurs after the formal acceptance by the City. Attention is also directed to provisions of Section 9-8, "Payment after Acceptance."

#### **7-18 PROPERTY RIGHTS IN MATERIALS**

Nothing in the Contract shall be construed as vesting in the Contractor any right of property in the materials used after they have been attached or affixed to the work or soil. All such material shall become the property of the City of Davis.

#### **7-19 PERSONAL LIABILITY**

Neither the City Council, the City Engineer, nor any other officer or authorized employee of the City of Davis shall be personally responsible for any liability arising under or by virtue of the Contract.



## **SECTION 8 PROSECUTION AND PROGRESS**

### **8-1 SUBCONTRACTING**

The Contractor shall give personal attention to the fulfillment of the Contract and shall control the work.

No subcontractor will be recognized as such, and all persons engaged in the work of construction will be considered as employees of the Contractor. The Contractor will be held responsible for the subcontractor's work, which work shall be subject to the provisions of the Contract and Specifications.

The Contractor's own organization shall perform Contract work amounting to not less than 50 percent of the original total Contract price, except that any designated "Specialty Items" may be performed by subcontract. The amount of any such "Specialty Items" so performed may be deducted from the original total Contract price before computing the amount of work required to be performed by the Contractor's own organization. When items of work in the Engineer's Estimate are preceded by the letter (S), said items are designated "Specialty Items." Where an entire item is subcontracted, the value of work subcontracted will be based on the Contract item bid price. When a portion of any item is subcontracted, the value of work subcontracted will be based on the estimated percentage of the Contract item bid price, determined from information submitted by the Contractor, subject to approval by the City Engineer.

Before work is started on a subcontract, the Contractor shall file with the City Engineer a written statement showing the work to be subcontracted, the names of the subcontractors and the description of each portion of the work to be so subcontracted.

When a portion of the work which has been subcontracted by the Contractor is not being prosecuted in a manner satisfactory to the City, the subcontractor shall be removed immediately, when required by the City Engineer, and shall not again be employed on the work.

#### **8-1.1 SUBCONTRACT DOCUMENTS**

Subcontracts shall include provisions that the Contract between the City and Contractor is part of the subcontract, and that all terms and provision of said Contract are incorporated in the subcontract. Subcontracts shall also contain certification by the subcontractor that said subcontractor is experienced in and qualified to do, and knowledgeable about, the subcontracted work. Copies of subcontracts shall be available to the City Engineer upon written request, and shall be provided to the City Engineer at the time any litigation is filed against the City concerning the project.

### **8-2 ASSIGNMENT**

The performance of the Contract may not be assigned, except upon the written consent of the City Council. Consent will not be given to any proposed assignment which would relieve the original

Contractor or surety of their responsibilities under the Contract nor will the City Council consent to any assignment of a part of the work under the Contract.

The Contractor may assign money due or to become due under the Contract and such assignment will be recognized by the City, if given proper notice thereof, to the extent permitted by law, but any assignment of money shall be subject to all proper set-offs in favor of the City and to all deductions provided for in the Contract. All money withheld, whether assigned or not, shall be subject to being used by the City for the completion of the work in the event that the Contractor should be in default therein.

### **8-3 BEGINNING OF WORK**

After the Contract has been executed, the City will issue to the Contractor a written notice stating the first working day of the Contract. The Contractor shall diligently prosecute the Contract to completion within the specified time limit.

Time is of the essence in this Contract.

Should the Contractor begin work in advance of receiving notice that the Contract has been approved as above provided, any work performed in advance of the said date of approval shall be considered as having been done at the Contractor's own risk and as a volunteer unless said Contract is so approved.

The delivery of the Contract to the City, for execution and approval, properly executed on behalf of the Contractor and surety shall constitute the Contractor's authority to enter upon the site of the work and to begin operations, subject to assuming the risk of the disapproval of the Contract, as above provided, and subject also to the following:

- A. Notice in writing of the Contractor's intention to start work prior to approval, specifying the intended start date, shall be given to the City at least 24 hours in advance;
- B. The Contractor shall, on commencing operations, take all precautions required for public safety and shall observe all provisions of the Contract; and
- C. All work performed according to the Contract prior to its approval under the authorization hereof, will, when the Contract is approved, be considered authorized work and will be paid for as provided in the Contract.

#### **8-3.1 PRE-CONSTRUCTION CONFERENCE**

A pre-construction conference will be held at the office of the City Engineer (Davis Public Works Department, 1717 Fifth Street) for the purpose of discussing with the Contractor, the scope of work, Plans, Specifications, existing conditions, submittals, materials, construction equipment, and other essential matters relating to the satisfactory completion of the work. This conference will be held prior to the issuance of the Notice to Proceed on City projects or prior to commencing work on private development projects. The Contractor's representative(s) shall include the project onsite superintendent, other primary superintendents and may also include major sub-contractors.



#### **8-4 PROGRESS SCHEDULE**

On all City projects, a progress schedule shall be prepared and submitted prior to the Pre-Construction Meeting. An amount up to 10% of the first progress billing, or up to \$5,000, whichever is greater, shall be deducted from the first progress payment in the event that the Progress Schedule has not been submitted or a Business License has not been obtained prior to the date of the first billing for work completed by the Contractor. This deduction will be in addition to the normal 10% retention.

When requested by the City Engineer, the Contractor shall submit a practicable progress schedule within ten working days of the City Engineer's written request.

The Contractor may choose a form upon which to furnish the schedule. The schedule shall show the order in which the Contractor proposes to carry out the work, the dates on which the various salient features of the work will be started (including procurement of materials, plant, and equipment), the contemplated dates for completing the said salient features, the critical path (controlling items of work) and any float time for the work items. The progress schedules submitted shall be consistent in all respects with the time and order of work requirements of the Contract.

#### **8-5 TEMPORARY SUSPENSION OF WORK**

The City Engineer shall have the authority to suspend the work wholly or in part, for such period as deemed necessary, due to unsuitable weather, or to such other conditions as are considered unfavorable for the suitable prosecution of the work, or for such time as deemed necessary due to the failure on the part of the Contractor to carry out orders given, or to perform any provision of the Contract. The Contractor shall immediately comply with the written order of the City Engineer to suspend the work wholly or in part. The suspended work shall be resumed when conditions are favorable and methods are corrected, as ordered or approved in writing by the City Engineer.

In the event that a suspension of work is ordered as provided above, and should such suspension be ordered because the Contractor failed to carry out orders or to perform any provision of the contract; or because weather conditions are unsuitable for performing any item or items of work which the City Engineer judges could have been performed prior to such unsuitable weather had the Contractor diligently prosecuted the work when weather was suitable; the Contractor, at the Contractor's expense, shall do all the work necessary to provide a safe, smooth, and unobstructed passageway through the Construction area for use by public traffic during the period of such suspension, as provided in Sections 7-6, "Public Convenience," and 7-7, "Public Safety," and as specified in the Special Provisions for the work. In the event that the Contractor fails to perform the work above specified, the City will perform such work and the cost thereof will be deducted from money due or to become due the Contractor.

In the event of a suspension of work under any of the conditions set forth in this Section 8-5, such suspension of work shall not relieve the Contractor of responsibilities specified in Section 7, "Legal Relations and Responsibility."

## **8-6 TIME OF COMPLETION**

The Contractor shall complete all or any designed portion of the work called for under the Contract in all parts and requirements within the time set forth in the Special Provisions.

A working day is defined as any day, except as follows:

- A. Saturdays, Sundays and legal holidays;
- B. Days on which the Contractor is prevented by inclement weather or conditions resulting immediately therefrom adverse to the current controlling operation or operations, as determined by the City Engineer, from proceeding with at least 75 percent of the normal labor and equipment force engaged on such operation or operations for at least 60 percent of the total daily time being currently spent on the controlling operation or operations;
- C. Days on which the Contractor is prevented, by reason of requirements in the Special Provisions, from working on the controlling operation or operations for at least 60 percent of the total daily time being currently spent on such controlling operation or operations.

If any portion of a day is legal holiday, the entire day will be considered as a non-working day within the meaning of this Section 8-6. The City of Davis uses the CALTRANS Work Day Calendar, a copy of which may be obtained at the Public Works Office.

Should the Contractor prepare to begin work at the regular starting time of any day on which inclement weather, or the conditions resulting from the weather, or the condition of the work, prevents the work from beginning at the usual starting time, and the crew is dismissed as a result thereof, and the Contractor does not proceed with at least 75 percent of the normal labor and equipment force engaged in the current controlling operation, or operations, for at least 60 percent of the total daily time being currently spent on the controlling operation or operations, the Contractor will not be charged for a working day whether or not conditions should change thereafter during said day, and the major portion of the day could be considered to be suitable for such construction operations.

The current controlling operation or operations are to be construed to include any feature of the work considered at the time by the City Engineer and the Contractor, which, if delayed, will delay the time of completion of the Contract.

Determination that a day is a non-working day by reason of inclement weather or conditions resulting immediately therefrom shall be made and agreed upon during such day by conference between the City Engineer and the Contractor. In the event of failure to agree, the Contractor will be allowed 15 days from the issuance of the Weekly Statement of Working Days in which to file a written protest setting forth in what respects the Contractor differs from the City Engineer; otherwise the decision of the City Engineer shall be deemed to have been accepted by the Contractor as correct. The City Engineer will furnish the Contractor a Weekly Statement showing the number of working days charged to the Contract for the preceding week, the number of working days of time extensions being considered or approved, the number of working days originally specified for the completion of the Contract and the number of working days remaining to complete the Contract and the extended date



for completion thereof, except when working days are not being charged in accordance with the provisions in Section 8-5, "Temporary Suspension of Work."

### **8-7 LIQUIDATED DAMAGES**

If the work required under this Contract is not finished or completed within the number of days specified in the Special Provisions, or within any period of delay authorized by the City Engineer, or pursuant to a duly authorized Contract Change Order, the Contractor acknowledges and admits that damage will be sustained by the City. It is also agreed that it is and will be impracticable and extremely difficult to ascertain and determine the actual damage which the City will sustain in the event of and by reason of such delay. It is therefore agreed by the parties of this Contract that the Contractor will pay to the City, as fixed and liquidated damages and not as penalty, the sum set forth in the Special Provisions per calendar day for each and every calendar day's delay in finishing the work in excess of the number of working days prescribed. The Contractor agrees to pay said liquidated damages herein provided for. The Contractor further agrees that the City may deduct the amount thereof from any money due or that may become due the Contractor under the Contract. Both the Contractor and the Contractor's surety shall be liable for the total amount of liquidated damages.

It is further agreed that in case the work called for under the Contract is not finished and completed in all parts and requirements within the number of working days specified, the City Engineer shall have the right to increase the number of working days or not, as he may deem best to serve the interest of the City. If he decides to increase the said number of working days, he shall further have the right to charge to the Contractor, his heirs, assigns, or sureties and to deduct from the final payment for the work, all or any part, as he may deem proper, of the actual cost of engineering, inspection, superintendence, and other overhead expenses which are directly chargeable to the contract, and which accrue during the period of such extension. The cost of final surveys and preparation of the final estimate shall not be included in such charges.

The Contractor will be granted an extension of time and will not be assessed with liquidated damages or the cost of engineering and inspection for any portion of the delay in completion of the work beyond the time named in the Special Provisions for the completion of the work caused by: acts of God or of the public enemy, fire, floods, tidal waves, earthquakes, epidemics, quarantine restrictions, strikes, labor disputes, shortage of materials and freight embargoes, provided, that the Contractor shall notify the City Engineer in writing of the causes of delay within 15 days from the beginning of any such delay. The City Engineer shall ascertain the facts and the extent of the delay, and his findings thereon shall be final and conclusive.

No extension of time will be granted for a delay caused by a shortage of materials unless the Contractor furnishes to the City Engineer documentary proof that every effort has been made to obtain such materials from all known sources within reasonable reach of the work in a diligent and timely manner, and further proof in the form of supplementary progress schedules, as required in Section 8-4, "Progress Schedule," that the inability to obtain such materials when originally planned, did in fact cause a delay in final completion of the entire work, which delay could not be compensated for by revising the sequence of the Contractor's operations. The term "shortage of materials," as used in this Section, shall apply only to materials, articles, parts or equipment which are standard items and are to be incorporated in the work. The term "shortage of materials," shall not apply to materials, parts, articles or equipment which are processed, made, constructed, fabricated or



manufactured to meet the specific requirements of the Contract. Only the physical shortage of material will be considered under this provision as a cause for extension of time. Delays in obtaining materials due to priority in filling orders will not constitute a shortage of materials.

Except for the additional compensation provided for in Section 8-9, "Right-Of-Way Delays," and except as provided in Public Contract Code Section 7102, the Contractor shall have no claim for damage or compensation, for any delay or hindrance.

It is the intent of the above provisions that the Contractor shall not be relieved of liability for liquidated damages or engineering and inspection charges for any period of delay in completion of the work in excess of that expressly provided for in this Section 8-7.

Payment by the City of any progress payments, after the specified date of completion, shall not constitute a waiver by the City of its right to claim liquidated damages, in accordance with this Section.

#### **8-8                   TERMINATION OF CONTROL**

The Contract may be canceled by the City without liability for damage when, in the opinion of the City, the Contractor is not complying in good faith, has become insolvent, or has assigned or subcontracted any part of the work without the City's consent. In the event of such cancellation, the Contractor will be paid the actual amount due based on unit prices or lump sums bid for the quantity of work completed at the time of cancellation, less damages caused to the City by acts of the Contractor causing the cancellation. The Contractor, in having tendered a bid, shall be deemed to have waived any and all claims for damages because of cancellation of the Contract for any such reason. If the City declares the Contract canceled for any of the above reasons, written notice to that effect shall be served upon the Surety. The Surety shall, within five days, assume control and perform the work as successor to the Contractor.

If the Contractor fails to begin delivery of material and equipment, to commence work within the time specified, to maintain an acceptable rate of delivery of material, to execute the work in the manner and at such locations as specified, or fails to maintain a work program which will insure the City's interest, or, if the Contractor is not carrying out the intent of the Contract, the City Engineer's written notice may be served upon the Contractor, and the Surety on its Faithful Performance Bond, demanding satisfactory compliance with the Contract.

If the Contractor or its Surety does not comply with such notice within five days after receiving it, or after starting to comply, fails to continue, the City may exclude it from the premises and take possession of all material and equipment, and complete the work, by City forces or by letting the unfinished work to another Contractor, or by a combination of such methods. In any event, the cost of completing the work shall be charged against the Contractor and its Surety, and may be deducted from any money due or becoming due from the City. If the sums under the Contract are insufficient for completion, the Contractor or Surety shall pay to the City within five days after completion, all costs in excess of the Contract price.

If the Surety assumes any part of the work, it shall take the Contractor's place in all respects for that part, and shall be paid by the City for all work performed by it in accordance with the Contract. If the



Surety assumes the entire contract, all money due the Contractor at the time of its default shall be payable to the Surety as the work progresses, subject to the terms of the Contract.

The provisions of this Section shall be in addition to all other rights and remedies available to the City under law. The City has the full right to pursue all of its legal and equitable remedies in regard to breach of this Contract.

### **8-9 RIGHT-OF-WAY DELAYS**

If, through an act of commission or omission by the City, the Contractor sustains loss which could not have been avoided by the judicious handling of forces, equipment and plant, the Contractor shall be entitled to reasonable compensation for such part of the Contractor's actual loss, which in the opinion of the City Engineer, was unavoidable.

Actual loss shall be understood to include no items of expense other than idle time of equipment and necessary payments for idle time of workers.

Compensation for idle time of equipment will be determined in the same manner as determinations are made for equipment used in the performance of extra work paid for on a force account basis, modified by application of the Delay Factor then current, as provided in the California Department of Transportation publication, "Labor Surcharge and Equipment Rental Rates," as required in Section 9-3.1.3, "Equipment Rental."

Compensation for idle time of workers will be determined as provided in Section 9-3.1.1, "Labor," and no markup will be added in either case for overhead and profit.

### **8-10 TERMINATION OF CONTRACT**

The Contract may be terminated by the Public Works Director when termination is authorized by Section 7-12, "Legal Actions Against the City," or by other provisions of the Contract which authorize termination. The City also reserves the right to terminate the Contract at any time upon a determination by the City that termination of the Contract is in the best interest of the City.

If the Public Works Director elects to terminate the Contract, the termination of the Contract and the total compensation payable to the Contract shall be governed by the following:

#### **8-10.1 TERMINATION PROCEDURE**

The City Engineer will issue the Contractor a written notice signed by the Public Works Director, specifying that the Contract is to be terminated. Upon receipt of said written notice, the Contractor will be relieved of further responsibility for damage to the work (excluding materials) as specified in Section 7-16, "Contractor's Responsibility for the Work and Materials," and, except as otherwise directed in writing by the City Engineer, the Contractor shall:

**8-10.1.1 STOP WORK**

Stop all work under the Contract except that specifically directed to be completed prior to acceptance.

**8-10.1.2 PERFORM WORK AS DIRECTED.**

Perform work the City Engineer deems necessary to secure the project for termination.

**8-10.1.3 EQUIPMENT AND PLANT**

Remove equipment and plant from the site of the work.

**8-10.1.4 PROTECT MATERIALS**

Take such action as is necessary to protect materials from damage.

**8-10.1.5 NOTIFY SUBCONTRACTORS AND SUPPLIERS**

Notify all subcontractors and suppliers that the Contract is being terminated and that their contracts or orders are not to be further performed, unless otherwise authorized in writing by the City Engineer.

**8-10.1.6 INVENTORY LIST**

Provide the City Engineer with an inventory list of all materials previously produced, purchased or ordered from suppliers for use in the work and not yet used in the work, including its storage location, and such other information as the City Engineer may request.

**8-10.1.7 UNUSED MATERIALS**

Dispose of materials not yet used in the work as directed by the City Engineer. It shall be the Contractor's responsibility to provide the City with good title to all materials purchased by the City hereunder, including materials for which partial payment has been made as provided in Section 9-6, "Partial Payments," and to provide bills of sale or other documents of title for such materials.

**8-10.1.8 OUTSTANDING CLAIMS AND LIABILITIES**

Subject to the prior written approval of the City Engineer, settle all outstanding liabilities and all claims arising out of subcontracts or orders for materials terminated hereunder. To the extent directed by the City Engineer, the Contractor shall assign to the City all the right, title and interest of the Contractor under subcontracts or orders for materials terminated hereunder.



**8-10.1.9 FURNISH DOCUMENTATION**

Furnish the City Engineer with the documentation required to be furnished by the Contractor under the provisions of the Contract including: projects for which Federal funds are involved, all documentation required under the Federal requirements included in the contract.

**8-10.1.10 OTHER ACTIONS AS DIRECTED**

Take such other actions as the City Engineer may direct.

**8-10.2 RESPONSIBILITY FOR DAMAGE TO MATERIALS**

Acceptance of the Contract as hereinafter specified shall not relieve the Contractor of responsibility for damage to materials. The Contractor shall continue to be responsible for damage to materials after issuance of the Notice of Termination, except as follows:

**8-10.2.1 RELIEF AFTER PARTIAL PAYMENT**

The Contractor's responsibility for damage to materials for which partial payment has been made as provided in Section 9-6, "Partial Payments," and for unused materials furnished by the City for use in the work, shall terminate when the City Engineer certifies that such materials have been stored in the manner and at the desired locations as directed.

**8-10.2.2 RELIEF AFTER DELIVERY**

The Contractor's responsibility for damage to materials purchased by the City, subsequent to the issuance of the notice that the Contract is to be terminated, shall terminate when title and delivery of such materials has been taken by the City.

**8-10.2.3 RELIEF AFTER COMPLETION**

After determining the Contractor has completed the work under the Contract, which work was directed to be completed prior to termination and such other work as may have been so ordered to secure the project for termination, the City Engineer will recommend that the City formally accept the Contract. Immediately upon and after such acceptance by the City, the Contractor will not be required to perform any further work thereon and shall be relieved of any contractual responsibilities for injury to persons or property which occurs after the formal acceptance of the project by the City.

**8-10.3 SURETY OBLIGATION**

Termination of the Contract shall not relieve the surety of its obligation for any just claims arising out of the work performed.

**8-10.4 TOTAL COMPENSATION**

The total compensation to be paid to the Contractor shall be determined by the City Engineer on the basis of the following:

**8-10.4.1 REASONABLE COST**

The reasonable cost to the Contractor, without profit, for all work performed under the Contract, including mobilization, demobilization and work performed to secure the project for termination. In determining the reasonable cost, deductions will be made for the cost of materials to be retained by the Contractor, amounts realized by the sale of materials, and for other appropriate credits against the cost of the work. Reasonable cost will include a reasonable allowance for project overhead and general administrative overhead not to exceed a total of seven percent of direct costs of such work.

When, in the opinion of the City Engineer, the cost of a Contract item of work is excessively high due to costs incurred to remedy or replace defective or rejected work, the reasonable cost to be allowed will be the estimated reasonable cost of performing such work, in compliance with the requirements of the Plans and Specifications. The excessive actual cost shall be disallowed.

**8-10.4.2 ALLOWANCE FOR PROFIT**

A reasonable allowance for profit on the cost of the work performed as determined under Section 8-10.4.1, provided the Contractor establishes, to the satisfaction of the City Engineer, that it is reasonably probable that the Contractor would have made a profit, had the Contract been completed. The profit allowed shall in no event exceed four percent of cost.

**8-10.4.3 VENDOR COSTS**

The reasonable cost to the Contractor of handling material returned to the vendor, which material was delivered to the City or otherwise disposed of, as directed by the City Engineer.

**8-10.4.4 ADMINISTRATIVE COSTS**

A reasonable allowance for the Contractor's administrative costs in determining the amount payable due to termination of the Contract.

**8-10.5 RECORDS**

All records, of the Contractor and subcontractors, necessary to determine compensation in accordance with the provisions of this Section 8-10, shall be open to inspection or audit by representatives of the City, at all times after issuance of the notice that the Contract is to be terminated. Such records shall be retained and kept open for inspection or audit for a period of three years.



**8-10.6 INTERIM PAYMENTS**

After acceptance of the work by the City, the City Engineer may make payments on the basis of interim estimates, pending issuance of the Final Estimate, in accordance with Section 9-8.1, "Final Payment and Claims," provided that in the City Engineer's opinion, the amount thus paid, together with all amounts previously paid or allowed, will not result in total compensation in excess of that to which the Contractor will be entitled. All payments, including payment upon the Final Estimate shall be subject to deduction for prior payments and amounts, if any, to be kept or retained under the provisions of the Contract.

**8-10.7 SUBCONTRACT REQUIREMENT**

The provisions of this Section 8-10 shall be included in all subcontracts.

**8-11 CITY'S RIGHT TO TAKE POSSESSION OF THE WORK IN WHOLE OR IN PART**

It is agreed that the City of Davis has the right, at any time, to enter upon the premises of the work and perform work not covered by this Contract, either by day labor, or by direct contract with other contractors, or to occupy and use a portion of the premises prior to the date of the final acceptance of the work as a whole, without in any way relieving the Contractor of any obligations under this Contract.

Such use or occupation of the premises shall not be construed as an acceptance of any portion of the work under this Contract.

**8-12 COMPLETION**

The effective date of completion of the Contract work is the date of acceptance of the work by the City Engineer. All guarantees, warranties, and securities securing said guarantees and warranties shall commence on said date.

## **SECTION 9 MEASUREMENT AND PAYMENT**

### **9-1 MEASUREMENT OF QUANTITIES**

All work to be paid for at a Contract price per unit of measurement will be measured by the City Engineer in accordance with United States Standard Measures. A ton shall consist of 2,000 pounds avoirdupois.

The Contractor shall bear the expense of and make all arrangements for the measurement of materials paid for by weight.

All weighing, measuring and metering devices used to measure the quantity of materials, used in the work, shall be suitable for the purpose intended, and shall conform to the tolerances and specifications as outlined in Sections 12500 to 12517 inclusive of the Business and Professions Code, and these Specifications.

Whenever pay quantities of material are determined by weighing, the scales shall be operated by a weighmaster licensed in accordance with the provisions of Sections 12700 to 12736 inclusive of the California Business and Professions Code. Upon request by the City Engineer, the Contractor shall furnish a Public Weighmaster's Certificate, or a Private Weighmaster's Certificate, or certified daily summary weigh sheets. A representative of the City may, at the discretion of the City Engineer, be present to witness the weighing and to check and compile the daily record of such scale weights.

The operator of each vehicle weighed shall obtain a weight or load slip from the weigher and deliver said slip to the City Engineer at the point of delivery of the material.

Vehicles used to haul material being paid for by weight shall be weighed empty daily, and at such additional times as the City Engineer may direct. Each vehicle shall bear a plainly legible identification mark.

Quantities of material wasted, or disposed of, in a manner not called for under the Contract; or rejected loads of material, including material rejected after it has been placed by reason of failure of the Contractor to conform to the provisions of the Contract; or material not unloaded from the transporting vehicle; or material placed outside of the lines indicated on the plans or established by the City Engineer; or material remaining on hand after completion of the work, will not be paid for and such quantities will be deducted from the final total quantities. No compensation will be allowed for hauling and disposing of rejected material.

Full compensation for all expenses involved in conforming to the requirements specified in this Section 9-1, shall be considered as included in the unit prices paid for the materials being measured or weighed, and no additional compensation will be allowed therefor.

### **9-2 SCOPE OF PAYMENT**

The Contractor shall accept the compensation provided in the Contract as full payment for furnishing all labor, materials, tools, equipment, and incidentals necessary to the completed work and for



performing all work contemplated and embraced under the Contract; also for loss or damage arising from the nature of the work, or from the action of the elements, or from any unforeseen difficulties which may be encountered during the prosecution of the work until acceptance by the City; and for all risks of every description connected with the prosecution of the work; and, for all expenses incurred in consequence of the suspension or discontinuance of the work as provided in the Contract; and for completing the work according to the plans and specifications. Neither the payment of any estimate nor of any retained percentage shall relieve the Contractor of any obligation to make good any defective work or material.

No compensation will be made in any case for loss of anticipated profits.

### **9-3 FORCE ACCOUNT PAYMENT**

When extra work is to be paid for on a force account basis, the labor, materials and equipment used in the performance of such work shall be subject to the approval of the City Engineer, and compensation being determined as follows:

#### **9-3.1 WORK PERFORMED BY CONTRACTOR**

The Contractor will be paid the direct costs for labor, materials and equipment used in performing the work determined as hereinafter provided in Sections 9-3.1.1, "Labor," 9-3.1.2, "Materials," and 9-3.1.3, "Equipment Rental."

To the total of the direct costs computed as provided in Sections 9-3.1.1, "Labor," 9-3.1.2, "Materials," and 9-3.1.3, "Equipment Rental," there will be added a markup of 33 percent to the cost of labor, 15 percent to the cost of materials, and 15 percent to the equipment rental. When extra work, to be paid for by force account methods, is performed by a subcontractor(s), an additional 5 percent markup will be added to the total cost of that extra work including all markups specified in this Section 9-3.1.

The above markups shall constitute full compensation for all overhead costs which shall be deemed to include all items of expense not specifically designated as cost or equipment rental in Sections 9-3.1.1, "Labor," 9-3.1.2, "Materials," and 9-3.1.3, "Equipment Rental." The total payment made as provided above shall be deemed to be the actual cost of such work and shall constitute full compensation therefor.

When extra work paid for on a force account basis is performed by forces other than the Contractor's organization, the Contractor shall reach agreement with such other forces as to the distribution of the payment made by the City for such work. No additional payment therefor will be made by the City by reason of the performance of the work by a subcontractor or other forces.

#### **9-3.1.1 LABOR**

The Contractor will be paid the cost of labor for the workers including foremen when authorized by the City Engineer, used in the actual and direct performance of the work. The cost of labor, whether the employer is the Contractor, subcontractor, or other forces, will be based on the following sub-sections 9-3.1.1.1 and 9-3.1.1.2.

**9-3.1.1.1 ACTUAL WAGES**

The actual wages paid shall include any employer payments to or on behalf of the workers for health and welfare, pension, vacation, and similar purposes.

**9-3.1.1.2 LABOR SURCHARGE**

To the actual wages, as defined in Section 9-3.1.1.1, will be added a labor surcharge set forth in the California Department of Transportation publication, "Labor Surcharge and Equipment Rental Rates," which is in effect on the date upon which the work is accomplished and which is a part of the Contract. The labor surcharge shall constitute full compensation for all payments imposed by State and Federal laws and for all other payments made to, or on behalf of, the workers, other than actual wages as defined in Section 9-3.1.1.1.

**9-3.1.2 MATERIALS**

The City reserves the right to furnish such materials as it deems advisable, and the Contractor shall have no claims for costs and markup on such materials.

Only materials furnished by the Contractor and necessarily used in the performance of the work will be paid for. The cost of such materials will be the cost to the purchaser, whether Contractor, subcontractor or other forces, from the supplier thereof, except when the following sub-sections 9-3.1.2.1 to 9-3.1.2.5, inclusive, are applicable.

**9-3.1.2.1 CASH OR TRADE DISCOUNT**

If a cash or trade discount by the actual supplier is offered or available to the purchaser, it shall be credited to the City notwithstanding the fact that such discount may not have been taken.

**9-3.1.2.2 INDIRECT PURCHASES**

If materials are procured, by the purchaser, by any method which is not a direct purchase from and a direct billing by the actual supplier to such purchaser, the cost of such materials shall be deemed to be the price paid to the actual supplier as determined by the City Engineer, plus the actual costs, if any, incurred in the handling of such materials.

**9-3.1.2.3 SUPPLIERS OWNED BY CONTRACTOR**

If the materials are obtained from the supply or source owned wholly or in part by the purchaser, the cost of such materials, shall not exceed the price paid by the purchaser for similar materials furnished from said source on Contract items, or the current wholesale price for such materials delivered to the job site, whichever price is lower.



**9-3.1.2.4 COSTS AT WHOLESALE**

If the cost of such materials is, in the opinion of the City Engineer, excessive, then the cost of such material shall be deemed to be the lowest current wholesale price at which such materials are available in the quantities concerned delivered to the job site, less any discounts as provided in the above subsection 9-3.1.2.1.

**9-3.1.2.5 NO EVIDENCE OF COST**

If the Contractor does not furnish satisfactory evidence of the cost of such materials from the actual supplier thereof, the cost shall then be determined in accordance with the above subsection 9-3.1.2.4.

**9-3.1.3 EQUIPMENT RENTAL**

The Contractor will be paid for the use of equipment at the rental rates listed for such equipment in the edition of the California Department of Transportation publication, "Labor Surcharge and Equipment Rental Rates," which is in effect on the date upon which the work is accomplished and which is a part of the Contract, regardless of ownership and any rental or other agreement, if such may exist, for the use of such equipment entered into by the Contractor. If it is deemed necessary by the City Engineer to use equipment not listed in said publication, a suitable rental rate for such equipment will be established by the City Engineer. The Contractor may furnish any cost data which might assist the City Engineer in the establishment of such rental rate.

The rental rate paid as above provided shall include the cost of fuel, oil, lubrication, supplies, small tools, necessary attachments, repairs and maintenance of any kind, depreciation, storage, insurance and all incidentals.

Operators of rented equipment will be paid for as provided in Section 9-3.1.1, "Labor."

All equipment shall, in the opinion of the City Engineer, be in good working condition and suitable for the purpose for which the equipment is to be used.

Unless otherwise specified, manufacturer's ratings and manufacturer approved modifications shall be used to classify equipment for the determination of applicable rental rates. Equipment which has no direct power unit shall be powered by a unit of at least the minimum rating recommended by the manufacturer. Individual pieces of equipment or tools not listed in said publication and having a replacement value of \$150 or less, whether or not consumed by use, shall be considered to be small tools and no payment will be made therefor.

**9-3.1.3.1 RENTAL TIME**

The rental time to be paid for equipment on the work shall be the time the equipment is in operation on the extra work being performed.

The following shall be used in computing the rental time of equipment on the work:

1. When hourly rates are listed, less than 30 minutes of operation shall be considered to be 1/2 hour of operation;

2. When daily rates are listed, less than four hours of operation shall be considered to be 1/2 day of operation; and
3. Rental time will not be allowed while equipment is inoperative due to breakdowns.

### **9-3.1.3.2 TRANSPORTATION COST**

For the use of equipment moved in on the work and used exclusively for extra work paid for on a force account basis, the Contractor will be paid for the cost of transporting the equipment to the location of the work and its return to its original location, all in accordance with the following provisions:

1. The original location of the equipment to be hauled to the location of the work shall be agreed to by the City Engineer in advance;
2. The City will pay the costs of loading and unloading such equipment;
3. The cost of transporting equipment in low bed trailers shall not exceed the hourly rates charged by established haulers;
4. The cost of transporting equipment shall not exceed the applicable minimum established rates of the Public Utilities Commission;
5. Should the Contractor desire the return of the equipment to a location other than its original location, the City will pay the cost of transportation in accordance with the above provisions, provided such payment shall not exceed the cost of moving the equipment to the work; and
6. Payment for transporting and loading and unloading equipment, as above provided, will not be made if the equipment is used on the work in any other way than upon extra work paid for on a force account basis.

### **9-3.2 RECORDS**

The Contractor shall maintain project records in such a manner as to provide a clear distinction between the direct costs of extra work paid for on a force account basis and the costs of other operations.

From the above records, the Contractor shall furnish the City Engineer completed Daily Extra Work Reports, for each day's extra work to be paid for on a force account basis. The Daily Extra Work Reports shall itemize the materials used, and shall cover the direct cost of labor and the charges for equipment rental, whether furnished by the Contractor, subcontractor, or other forces. The Daily Extra Work Reports shall provide names or identifications and classifications of workers, the hourly rate of pay and hours worked, and the size, type and identification number of equipment, and hours operated.



Material charges shall be substantiated by valid copies of vendor's invoices. Such invoices shall be submitted with the Daily Extra Work Reports, or if not available, they shall be submitted with subsequent Daily Extra Work Reports. Should said vendor's invoices not be submitted within 60 days after the date of delivery of the material or within 15 days after completion of the Contract, whichever occurs first, the City reserves the right to establish the cost of such materials at the lowest current wholesale prices at which said materials are available, in the quantities concerned, delivered to the location of work, less any discounts provided in Section 9-3.1.1.1.

Said Daily Extra Work Reports shall be signed by the Contractor or an authorized representative.

The City Engineer will compare the City's records with the completed Daily Extra Work Reports furnished by the Contractor and make any necessary adjustments. When these Daily Extra Work Reports are agreed upon and signed by both parties, said reports shall become the basis of payment for the work performed, but shall not preclude subsequent adjustment based on a later audit by the City.

The Contractor's cost records, pertaining to work paid for on a force account basis, shall be open to inspection or audit by representatives of the City, during the life of the Contract, and for a period of not less than 3 years after the date of acceptance thereof, and the Contractor shall retain such records for that period. Where payment, for materials or labor, is based on the cost thereof to forces other than the Contractor, the Contractor shall make every reasonable effort to insure that the cost records of such other forces will be open to inspection and audit, by representatives of the City, on the same terms and conditions as the cost records of the Contractor. If an audit is to be commenced more than 60 days after the acceptance date of the Contract, the Contractor will be given a reasonable notice of the time when such audit is to be given.

### **9-3.3 PAYMENT**

Payment as provided in Section 9-3.1, "Work Performed by Contractor," shall constitute full compensation to the Contractor, for performance of work paid for on a force account basis, and no additional compensation will be allowed therefor.

### **9-4 NOTICE OF POTENTIAL CLAIM**

The Contractor shall not be entitled to the payment of any additional compensation for any act, or failure to act, by the City Engineer, including failure or refusal to issue a Contract Change Order, or for the happening of any event, thing, occurrence, or other cause, unless, the Contractor shall have given the City Engineer due written notice of potential claim as hereinafter specified. Compliance with this Section 9-4 shall not be considered a prerequisite for matters within the scope of the protest provisions in Section 4-3, "Changes," or Section 8-6, "Time of Completion," or the notice provisions in Section 8-7, "Liquidated Damages," nor to any claim which is based on differences in measurements or errors of computation as to Contract quantities.

The written notice of potential claim shall set forth the reasons for which the Contractor believes additional compensation will or may be due, the nature of the costs involved, and, insofar as possible, the amount of the potential claim. The notice, as above required, must have been given to the City Engineer prior to the time that the Contractor shall have performed the work giving rise to the

potential claim for additional compensation, if based on an act or failure to act by the City Engineer, or in all other cases within 15 days after the happening of the event, thing, occurrence, or other cause, giving rise to the potential claim.

It is the intent of this Section 9-4 that differences between the parties arising, under and by virtue of the Contract be brought to the attention of the City Engineer, at the earliest possible time, in order that such matters may be settled, if possible, or other appropriate action promptly taken. The Contractor hereby acknowledges having no right to additional compensation for any claim that may be based on any such act, failure to act, event, thing or occurrence for which no written notice of potential claim was filed as herein required.

### **9-5 STOP NOTICES**

The City, by and through the City Engineer or other appropriate City officer or officers, may at its option and at any time retain out of any amounts due the Contractor, sums sufficient to cover claims, filed pursuant to Sections 3179 to 3214 inclusive of the Civil Code.

### **9-6 PARTIAL PAYMENTS**

The City Council, once in each month, shall cause an estimate, in writing, to be made by the City Engineer. The estimate shall include the total amount of work done and acceptable materials incorporated into the work.

The City shall retain 10 percent of the estimated value of the work done and acceptable materials incorporated into the work as partial security for the fulfillment of the Contract by the Contractor.

The City Engineer shall show on the estimate the balance of the amount due the Contractor, at the time of the estimate, less all previous payments and all sums to be kept or retained under the provisions of the Contract.

The Contractor shall, upon receipt of the estimate, submit to the City Engineer, for payment, an invoice reflecting the balance shown on the estimate.

No such estimate or payment shall be required to be made when, in the judgment of the City Engineer, the work is not proceeding in accordance with the provisions of the Contract, or the total value of the work done since the last estimate amounts to less than \$300.

No such estimate or payment shall be construed to be an acceptance of any defective work or improper materials. Attention is directed to the express prohibition against payment to unlicensed contractors contained in Section 7040 of the Business and Professions Code, the provisions of which are set forth in Section 7-1.9, "Contractor's Licensing Law."

Once each month (or once each 4 weeks to coincide with City payment schedule), the Contractor shall submit an invoice for work completed indicating thereon work completed in the previous period, work completed to date, amounts billed, and retained earnings. The Invoice shall be itemized according to the items of work in the Contract. The City Engineer will review and approve this



invoice within 7 days of submittal. Any invoices returned to the Contractor for further correction will be accompanied by a written explanation.

The City of Davis will make payments for any progress payment, except retained amounts, within 30 days of approval of an Invoice. In the event that the City fails to make payment within the 30 day period, then interest will be paid on the amount owed less retention amounts. The interest rate shall be as determined in Section 685.010 of the Civil Code.

In the event that the City Engineer takes longer than 7 days to review a Contractor Invoice, then the 30 day period shall be shortened by the number of days in excess of 7 days required to review and respond or approve the payment request.

### **9-7 SUBSTITUTION OF SECURITIES FOR WITHHELD MONEY**

Pursuant to Public Contract Code Section 22300, at the request and expense of the Contractor, securities equivalent to the amount withheld shall be deposited with the City, State Treasurer, or with a state or federally chartered bank in California as the escrow agent, who shall pay such moneys to the Contractor upon satisfactory completion of the contract

Alternatively, the Contractor may request, pursuant to Public Contract Code Section 22300, and the City shall make payment of retentions earned directly to the escrow agent. The Contractor shall receive the interest earned on the investments upon the same terms provided for in this Section for securities deposited by the Contractor. Upon satisfactory completion of the Contract, the Contractor shall receive from the escrow agent all securities, interest and payments received by the escrow agent from the City.

Securities eligible for investment under this Section shall include those listed in Government Code Section 16430 or bank or savings and loan certificates of deposit, interest-bearing demand deposit accounts, standby letters of credit, or any other security mutually agreed to by the Contractor and the City.

The Contractor shall be the beneficial owner of any securities substituted for moneys withheld and shall receive any interest thereon.

Any escrow agreement entered into pursuant to this Section shall be substantially similar to the form provided by Public Contract Code Section 22300(f).

### **9-8 PAYMENT AFTER ACCEPTANCE**

After the work has been accepted by the City, as provided in Section 7-17, "Acceptance of Contract," payments will be made to the Contractor subject to the provisions in this Section.

#### **9-8.1 FINAL PAYMENT AND CLAIMS**

After acceptance by the City, the City Engineer will prepare a proposed final estimate, in writing, of the total amount payable to the Contractor. This final estimate will include an itemization of the final Contract amount, segregated as to Contract item quantities, extra work and any other basis for

payment. It will show therein all deductions, made or to be made, for prior payments, and amounts to be kept or retained under the provisions of the Contract. All prior estimates and payments shall be subject to correction in the proposed final estimate.

The City shall file a Notice of Completion with the County Recorder's Office after acceptance of the Contract.

Within 30 days after recordation of the Notice of Completion, the Contractor shall submit to the City Engineer written approval of said proposed final estimate or a written statement of all claims arising under or by virtue of the Contract. No claim will be considered that was not included in said written statement of claims, nor will any claim be allowed for which a notice or protest is required by the provisions in Section 4-3, "Changes," 8-6, "Time of Completion," 8-7, "Liquidated Damages," and 9-4, "Notice of Potential Claim."

Upon the Contractor's approval, or failure to file a claim within said period of 30 days, the proposed final estimate submitted by the City Engineer shall become the final estimate, and within 30 days thereafter, the City will pay the entire sum so found to be due. Such final estimate and payment thereon shall be conclusive and binding against both parties to the Contract, on all questions relating to the amount of work done and the compensation payable therefor, except as otherwise provided in Sections 9-3.2, "Records," and 9-9, "Clerical Errors."

If the Contractor within said period of 30 days files claims, the City shall make payment based on the proposed final estimate, pending final determination, by the City Engineer, regarding said claims as provided in this Section 9-8.

The claims filed by the Contractor shall be in sufficient detail to enable the City Engineer to ascertain the basis and amount of said claims. The City Engineer will consider and determine the Contractor's claims. The Contractor must furnish within a reasonable time, such further information and details as may be required, by the City Engineer, to determine the facts or contentions involved in the claims. Failure to submit such information and details will be sufficient cause for denying the claims.

The City Engineer will make the final determination of any claims which remain in dispute after a completion of a claim's review. The Contractor may meet with the City Engineer to make a presentation in support of such claims.

Upon final determination of the claims, the City Engineer shall then make and issue a final estimate in writing. Within 30 days thereafter the City will pay the entire sum, if any, found due thereon. Such final estimate shall be conclusive and binding against both parties to the Contract, on all questions relating to the amount of work done and the compensation payable therefor, except as otherwise provided in Sections 9-3.2, "Records," and 9-9, "Clerical Errors."

## **9-9 CLERICAL ERRORS**

Notwithstanding the provisions in Section 9-8, "Payment After Acceptance," for a period of 3 years after acceptance of the work, all estimates and payment made pursuant to said Section 9-8, including the final estimate, shall be subject to correction and adjustment for clerical errors in the calculations involved in the determination of quantities and payments. The Contractor and the City agree to pay to



the other any sum due under the provisions of this Section 9-9, provided, however, if the total sum to be paid is less than \$200, no such payment shall be made.

## **9-10 RESOLUTION OF CONSTRUCTION CLAIMS**

Contractor claims up to and including the total amount of \$375,000 shall be subject to the provisions of this Section. Whenever the term claim or claims is used in this Section it shall mean all outstanding claims filed by a Contractor on a particular project, whether said claims are filed individually for single items of work or as one comprehensive claim for a variety of items. The dollar amount limits shall be applied based upon the sum of the value of all claimed amounts.

Article 1.5, Sections 20104- 20104.8, inclusive, of Chapter 1, Part 3, Division 2 of the Public Contract Code is the basis for this section on resolution of Contract claims.

This section shall not apply to any claims resulting from a contract where the City has required that disputes be resolved pursuant to the arbitration provisions of Article 7.1, "Resolution of Contract Claims," Chapter 1 of Part 2, Division 2 of the Public Contract Code.

### **9-10.1 TIME LIMITS FOR FILING CLAIMS**

All claims shall be filed in accordance with the provisions of Sections 4-3.1, "Procedure and protest," 9-4 "Notice of Potential Claim," and 9-8.1 "Final Payment and Claims." All claims must be filed on or before the date of final payment. The date of final payment shall be considered to be 30 days after recordation of the Notice of Completion.

### **9-10.2 WRITTEN FORM OF CLAIMS**

All claims shall be prepared and submitted in a written form, complete with supporting documents and other evidence. Any subsequent responses to requests for clarification or for additional information shall be presented in a written form.

### **9-10.3 INITIAL CITY RESPONSE TO CLAIMS**

The City Engineer shall review the claim and respond within the time limits specified below.

#### **9-10.3.1 RESPONSE TIMES FOR CLAIMS OF LESS THAN \$50,000**

The City will respond within 30 days of receipt of the claim with any requests for additional information or clarification. After receipt of any subsequent documents supporting the claim, the City will respond with a decision within 15 days, or the time period taken by the claimant to respond to the request, whichever is greater. If no additional supporting information is requested, then the City will respond within 45 days after receipt of the written claim.

**9-10.3.2      RESPONSE TIME FOR CLAIMS OF \$50,000 TO \$375,000**

The City will respond within 30 days of receipt of the claim with any requests for additional information or clarification. After receipt of any subsequent documents supporting the claim; the City will respond with a decision within 30 days, or the time period taken by the claimant to respond to the request, whichever is greater. If no additional supporting information is requested, then the City will respond within 60 days after receipt of the written claim.

**9-10.4            CLAIMANT REJECTS INITIAL CITY DECISION**

If the claimant disagrees with the City decision in regard to the written claim, or if the City fails to respond within the prescribed time limits, then the claimant may demand, in writing, an informal conference to meet and confer for settlement of the issues in dispute. This demand from the claimant shall be submitted within 15 days of receipt of the City decision or within 15 days of the City's failure to respond.

**9-10.4.1        INFORMAL MEET AND CONFER CONFERENCE**

The City shall schedule a meeting time and place within 30 days of the receipt of the claimant demand for an Informal Meet and Confer Conference.

**9-10.5            CIVIL ACTION**

For any claims or portions of claims remaining in dispute following the meet and confer process, the claimant may file a claim pursuant to Chapter 1 and Chapter 2 of Part 3 of Division 3.6 of Title 1 of the Government Code. The Contractor's attention is directed to the provisions of Public Contract Code Sections 20104.2(e), 20104.2(f) and 20104.4 which apply to the filing of civil actions by the claimant and provide for mediation and arbitration of the civil action.

**9-10.6            PAYMENT OF UNDISPUTED AMOUNTS**

The City will pay in full, in accordance with the terms of the Standard Specifications, any undisputed Contract amounts not a part of this claims process.

**9-10.7            INTEREST ON CLAIM**

The City will pay the legal rate of interest on any arbitration or judgment commencing on the date which the claim was filed in a court of law.





# PART TWO

## CONSTRUCTION MATERIALS

### SECTION 200

#### ROCK AND EARTH MATERIALS

##### **200-1 AGGREGATE BASE**

Aggregate base shall conform to the grading and quality requirements of Section 26-1.02A "Class 2 Aggregate Base" of the State Specifications, 3/4" maximum.

Recycled Class 2 Aggregate Base may be used after first submitting current gradation with certification that the recycled material can meet State Specifications for Class 2 Aggregate Base

##### **200-2 AGGREGATE SUBBASE**

Aggregate Subbase shall conform to the grading and quality requirements of Class 2 Aggregate Subbase, 2-1/2" maximum, as specified in Section 25-1.02A, "Class 1, Class 2, and Class 3 Aggregate Subbases" of the State Specifications.

Asphalt concrete grindings that meet the above specifications may be used as aggregate subbase in street structural sections or as subbase backfill in trenches.

##### **200-3 CRUSHED ROCK**

Crushed rock shall be the product of crushing rock or gravel. At least 50 percent of the material that will pass a 3/8-inch (9.5 mm) sieve shall consist of particles having three or more faces, which result from fracture due to mechanical crushing. Of the material passing said sieve, not more than five percent shall be pieces that show no such faces resulting from crushing. Of that portion which passes the 3/8-inch (9.5 mm) sieve but is retained on the No. 4 sieve, not more than ten percent shall be gravel particles. Crushed rock will be designated by nominal size and shall conform to the following gradations:

| <b>CRUSHED ROCK GRADATION REQUIREMENTS</b> |                           |        |        |        |        |       |           |
|--|---------------------------|--------|--------|--------|--------|-------|-----------|
| Nominal Size Specified                     | 1"                        | 3/4"   | 1/2"   | 3/8"   | 1/4"   | 3/16" | Rock Dust |
| Sieve Size                                 | Percentage Passing Sieves |        |        |        |        |       |           |
| 1-1/2" (38.1mm)                            | 100                       | n/a    | n/a    | n/a    | n/a    | n/a   | n/a       |
| 1" (25.4mm)                                | 90-100                    | 100    | n/a    | n/a    | n/a    | n/a   | n/a       |
| 3/4" (19.0mm)                              | 30-60                     | 90-100 | 100    | n/a    | n/a    | n/a   | n/a       |
| 1/2" (12.7mm)                              | 0-20                      | 30-60  | 90-100 | 100    | n/a    | n/a   | n/a       |
| 3/8" (9.5mm)                               | n/a                       | 0-20   | 20-60  | 90-100 | n/a    | n/a   | 100       |
| 1/4" (6.4mm)                               | n/a                       | n/a    | n/a    | n/a    | 100    | n/a   | n/a       |
| No. 4 (4.8mm)                              | 0-5                       | 0-5    | 0-5    | 40-70  | 15-100 | 100   | 90-100    |
| No. 8                                      | n/a                       | n/a    | n/a    | 0-10   | 0-25   | 40-75 | n/a       |
| No. 16                                     | n/a                       | n/a    | n/a    | n/a    | 0-5    | 0-10  | n/a       |
| No. 30                                     | n/a                       | n/a    | n/a    | n/a    | n/a    | n/a   | 20-60     |
| No. 200                                    | n/a                       | n/a    | n/a    | n/a    | 0-2    | 0-2   | 5-20      |
| ASTM C131 Testing Grading                  | A                         | B      | B      | C      | D      | D     | n/a       |

Table Note: "n/a" denotes not applicable

**200-4 DECOMPOSED GRANITE**

Decomposed Granite shall consist of quarry waste or other approved materials, free of adobe, vegetable matter, loam and other deleterious substances. It shall be of such quality so as to compact thoroughly, to form a firm walking surface, which displays a minimum of scuffing or dusting. The material shall conform to the following gradation of fines and aggregates:

| <b>DECOMPOSED GRANITE GRADATION</b> |                    |
|-------------------------------------|--------------------|
| Sieve Sizes                         | Percentage Passing |
| 3/8"                                | 100                |
| No. 3                               | 95-100             |
| No. 8                               | 50-90              |
| No. 200                             | 10-20              |

Color shall be TAN. A sample shall be submitted to the City Engineer for approval.

**200-5 SELECT MATERIAL**

Select material shall consist of clean earthen materials, ranging in size from silts and clays to sands and gravels. It may also include pulverized portions of asphalt concrete pavement or Portland cement concrete. There shall be no roots, rubbish, organic matter, or other deleterious substances. It shall have a sand equivalent value of not less than 20, and shall conform to the following gradation requirements:

| SELECT MATERIAL GRADATION |                    |
|---------------------------|--------------------|
| Sieve Sizes               | Percentage Passing |
| 3"                        | 100                |
| No. 4                     | 35-100             |
| No. 30                    | 20-100             |

Material conforming to or exceeding the requirements for Class 2 aggregate subbase, as defined in Section 25, "Aggregate Subbases," of the State Specifications is an acceptable alternative.

**200-6 SAND**

Sand shall consist of natural or manufactured granular material, or a combination thereof. It shall not contain any roots, rubbish, organic matter, or other deleterious substances. Where clean washed sand is specified, the sand shall be washed by the supplier during manufacturing and/ or preparation process. Sand shall conform to the following gradation requirements.

| SAND GRADATION REQUIREMENTS |                    |
|-----------------------------|--------------------|
| Sieve Sizes                 | Percentage Passing |
| No. 4                       | 100                |
| No. 8                       | 65-100             |
| No. 16                      | 45-75              |
| No. 30                      | 30-50              |
| No. 50                      | 10-30              |
| No. 100                     | 0-10               |
| No. 200                     | 0-5                |

Sand conforming to the requirements for "Concrete Sand" per ASTM C33 is an acceptable alternate material.

**200-7 PERMEABLE FILTER MATERIAL**

Permeable filter material shall conform to the provisions of Class 2 Permeable Material, as described in Section 68-1.025, "Permeable Material," of the State Specifications.



Permeable Filter Material for street underdrains shall be nominal one-fourth inch pea gravel. Substitute material may be allowed provided that no more than five percent passes a #4 sieve and 100 percent passes a 3/4" sieve. The grading of the material shall be uniform. It shall conform in all other respects to Section 68-1.025 "Permeable Material" of the State Specifications. The use of substitute material shall be subject to review and approval of the City prior to its use on the job.

All Filter Fabric for use in street underdrains shall conform to Section 88, "Engineering Fabrics," of the State Specifications. The material shall meet the requirements for underdrains as described in said section.

### **200-8 SLURRY CEMENT BACKFILL**

Slurry cement backfill shall conform to the provisions in Section 19-3.062, "Slurry Cement Backfill," of the State Specifications.

### **200-9 SLURRY SEAL AGGREGATE**

Aggregate shall consist of rock dust and plaster sand or other sands of similar nature, except that any aggregate or combination of aggregate used in the mixture shall contain not less than 50 percent of the product obtained by crushing rock. The material shall be free from vegetable matter and other deleterious substances.

The slurry seal shall be a Type I and the percentage composition by weight of the aggregate shall conform to the following gradation:

| <b>SLURRY SEAL TYPE I GRADATION</b> |                           |
|-------------------------------------|---------------------------|
| <b>Sieve Sizes</b>                  | <b>Percentage Passing</b> |
| No. 4                               | 100                       |
| No. 8                               | 90-100                    |
| No. 16                              | 60-90                     |
| No. 30                              | 40-65                     |
| No. 200                             | 10-20                     |

The aggregate shall also conform to the following quality requirements:

| AGGREGATE QUALITY REQUIREMENTS   |                 |                    |
|--|-----------------|--------------------|
| Sieve Sizes  | California Test | Percentage Passing |
| Sand Equivalent  | 217             | 45 Min.            |
| Film Stripping (test performed on the material passing the No. 8 sieve and retained on the No. 16 sieve) | 302             | 25% Max.           |
| Durability Index   | 229             | 60 Min.            |

**200-10 BEDDING**

The following material shall be used for pipe bedding:

- Sanitary sewer lines, storm drain lines, manholes, and other structures with the exception of cast-in-place pipe shall use 1/2-inch crushed rock per Section 200-3.
- Water mains including service lateral lines shall use clean, washed sand per Section 200-6.

## **SECTION 201 CONCRETE AND RELATED MATERIALS**

### **201-1 PORTLAND CEMENT CONCRETE**

Portland cement concrete shall conform to the requirements of Section 90-1.01, "Description" (Portland Cement Concrete) of the State Specifications. Unless otherwise specified in the contract documents, all Portland Cement Concrete shall be Class A (six sack mix). The minimum compressive strength shall be 3,000 psi, measured 28 days after placement, in accordance with standard testing procedures. The maximum allowable slump, measured at the placement end of the final delivery device, shall be five inches, unless otherwise permitted or directed by the City Engineer.

#### **201-1.1 PORTLAND CEMENT**

Portland Cement shall conform to the requirements of Section 90-2.01, "Cement" of the State Specifications.

#### **201-1.2 AGGREGATES**

Aggregates shall conform to the requirements of Section 90-2.02, "Aggregates" and Section 90-3, "Aggregate Gradings," of the State Specifications. Unless otherwise specified in the Special Provisions, the one-inch maximum combined aggregate grading shall be used.

#### **201-1.3 WATER**

Water used for mixing and curing concrete shall conform to the requirements of Section 90-2.03, "Water" of the State Specifications.

#### **201-1.4 MIXING OF CONCRETE**

Mixing of concrete shall conform to Section 303, "Portland Cement Concrete Construction," of these Specifications.

#### **201-1.5 ADMIXTURES**

Chemical admixtures shall conform to the requirements of Section 90-4, "Admixtures," of the State Specifications.

#### **201-1.6 POLYPROPYLENE FIBERS**

When specified in these Standards or Special Provisions, synthetic fibers to be added to concrete shall be fibrillated polypropylene olefin fibers such as Fibermesh by Propex Concrete Systems, or the equivalent.



**201-2 REINFORCEMENT FOR CONCRETE**

Reinforcement for concrete shall conform to Section 52, "Reinforcement" of the State Specifications.

**201-3 EXPANSION JOINT FILLER**

Expansion joint filler shall be a pre-molded joint filler, consisting of asphalt felt and asphalt fiber material, three-eighths inch thick and precut to conform accurately to the finished concrete section. The pre-molded joint filler shall conform to the specifications of ASTM D1751.

**201-4 CONCRETE CURING COMPOUND**

Concrete curing compound shall be a white-pigmented curing compound conforming to the requirements of Section 90-7.01B, "Curing Compound Method" of the State Specifications, for curing compound (B): Pigmented Curing Compound, conforming to ASTM C309, Type 2, Class B.

All compounds shall be furnished by the Contractor and shall be delivered in sealed original containers bearing the manufacturer's name and product identification.

**201-5 CEMENT MORTAR****201-5.1 GENERAL**

General cement mortar shall consist of a mixture of Portland cement, sand, and water. Cement mortar shall be such that it will adhere readily to concrete pipe or maintenance hole barrels and can be easily squeezed out at the joints. The cement mortar shall be composed of one part Portland cement and two parts sand. Admixtures of hydrated lime, fire clay, or other approved inert material may be used in the mortar to improve workability if the Contractor elects, but the amount of admixture to be added must be approved in advance by the City Engineer.

**201-5.2 SAND FOR CEMENT MORTAR**

Sand for cement mortar shall be well graded, with 100 percent passing a No. 8 sieve. It shall have a mortar strength, when tested in accordance with California Test 515, of at least 90 percent that of Ottawa sand.

**201-5.3 CEMENT**

Cement shall be Type 2 conforming to ASTM C150.

**201-5.4 WATER**

Water used for mixing mortar shall conform to the requirements of Section 90-2.03, "Water" of the State Specifications.



**201-6 PORTLAND CEMENT CONCRETE ADHESIVE**

The adhesive shall consist of two components which shall be mixed together at the site of the work. The epoxy shall conform to the requirements in Section 95-2.03, "Epoxy Resin Adhesive for Bonding New Concrete to Old Concrete," of the State Specifications.

## SECTION 202 BITUMINOUS MATERIALS

### 202-1 ASPHALT CONCRETE

Asphalt concrete shall be Type "A." The aggregate for Type "A" asphalt concrete shall be 1/2-inch maximum, medium grading as specified in Section 39, "Aggregate" of the State Standard Specifications.

Asphalt concrete to be used on bikepaths, only, shall be Type "A" and shall be 3/8-inch maximum aggregate.

Asphalt binder shall conform to the provisions in the following section and shall be PG 64-10 unless otherwise specified.

The Contractor shall furnish asphalt in conformance with the Caltrans "Certification Program for Suppliers of Asphalt." The program requirements, procedures, and a list of approved suppliers are located at:

<http://www.dot.ca.gov/hq/esc/Translab/ofpm/fpmcoc.htm>

(Note: website link is case-sensitive)

#### 202-1.1 MIX DESIGN

Hot mix asphalt (HMA) shall be produced in conformance with the requirements of a job-mix formula. The job-mix formula will take into consideration the quality of the aggregate, the type of asphalt binder material, the immersion compression retention index, the void relationships and other criteria, and said job-mix formula shall be the responsibility of the Contractor. The amount of asphalt binder material, as a percentage of the total weight of the mixture shall be determined by California Test 367 using samples of aggregates furnished by the Contractor in conformance with the provisions of State Specification Section 39-3.03, "Proportioning."

The Contractor shall be responsible for designing a job-mix formula through an approved testing laboratory, and shall submit it to the City Engineer for approval ten (10) working days prior to any mixing and/or placing of HMA.

Said job-mix formula shall be determined using the specifications set forth herein and shall conform to the requirements of Section 39-2.02 of the State Specifications. If the Contractor elects to use any material, including blending material, other than those materials utilized in the job-mix formula, he shall so inform the City Engineer in advance of the production of asphaltic concrete and shall document the request through an approved testing laboratory.

During the production of either mineral aggregate or asphaltic concrete, the Contractor may request that adjustments be made in the job-mix formula. Such request shall be in writing and substantiated through an approved testing laboratory. Consideration will be given promptly to such request.

**202-1.2 ASPHALT GRADES**

Performance graded (PG) asphalt binder shall conform to the following:

| <b>PERFORMANCE GRADED ASPHALT BINDER</b>  |                    |                         |                         |                         |                         |                         |
|---|--------------------|-------------------------|-------------------------|-------------------------|-------------------------|-------------------------|
| Property  | AASHTO Test Method | Specification Grade     |                         |                         |                         |                         |
|   |                    | PG 58-22 <sup>a</sup>   | PG 64-10                | PG 64-16                | PG 64-28                | PG 70-10                |
| <b>Original Binder</b>  |                    |                         |                         |                         |                         |                         |
| Flash Point, Minimum °C   | T48                | 230                     | 230                     | 230                     | 230                     | 230                     |
| Solubility, Minimum % <sup>b</sup>  | T44                | 99                      | 99                      | 99                      | 99                      | 99                      |
| Viscosity at 135°C, <sup>c</sup><br>Maximum, Pa·s   | T316               | 3.0                     | 3.0                     | 3.0                     | 3.0                     | 3.0                     |
| Dynamic Shear,<br>Test Temp. at 10 rad/s, °C<br>Minimum G*/sin(delta), kPa  | T315               | 58<br>1.00              | 64<br>1.00              | 64<br>1.00              | 64<br>1.00              | 70<br>1.00              |
| RTFO Test <sup>e</sup> ,<br>Mass Loss, Maximum, %   | T240               | 1.00                    | 1.00                    | 1.00                    | 1.00                    | 1.00                    |
| <b>RTFO Test Aged Binder</b>  |                    |                         |                         |                         |                         |                         |
| Dynamic Shear,<br>Test Temp. at 10 rad/s, °C<br>Minimum G*/sin(delta), kPa  | T315               | 58<br>2.20              | 64<br>2.20              | 64<br>2.20              | 64<br>2.20              | 70<br>2.20              |
| Ductility at 25°C<br>Minimum, cm  | T51                | 75                      | 75                      | 75                      | 75                      | 75                      |
| PAV <sup>f</sup> Aging,<br>Temperature, °C  | R28                | 100                     | 100                     | 100                     | 100                     | 110                     |
| <b>RTFO Test and PAV Aged Binder</b>  |                    |                         |                         |                         |                         |                         |
| Dynamic Shear,<br>Test Temp. at 10 rad/s, °C<br>Minimum G*/sin(delta), kPa  | T315               | 22 <sup>d</sup><br>5000 | 31 <sup>d</sup><br>5000 | 28 <sup>d</sup><br>5000 | 22 <sup>d</sup><br>5000 | 34 <sup>d</sup><br>5000 |
| Creep Stiffness,<br>Test Temperature, °C<br>Maximum S-value, MPa<br>Minimum M-value   | T313               | -12<br>300<br>0.300     | 0<br>300<br>0.300       | -6<br>300<br>0.300      | -18<br>300<br>0.300     | 0<br>300<br>0.300       |
| Notes:  |                    |                         |                         |                         |                         |                         |
| a. For use as asphalt rubber base stock for high mountain and high desert area.   |                    |                         |                         |                         |                         |                         |
| b. The City Engineer will waive this specification if the supplier is a Quality Supplier as defined by the Cal Trans "Certification Program for Suppliers of Asphalt."                  |                    |                         |                         |                         |                         |                         |
| c. The City Engineer will waive this specification if the supplier certifies the asphalt binder can be adequately pumped and mixed at temperatures meeting applicable safety standards. |                    |                         |                         |                         |                         |                         |
| d. Test the sample at 3°C higher if it fails at the specified test temperature. G*/sin(delta) shall remain 5000 kPa maximum.  |                    |                         |                         |                         |                         |                         |
| e. "RTFO Test" means the asphaltic residue obtained using the Rolling Thin Film Oven Test, AASHTO Test Method T240 or ASTM Designation: D 2872.   |                    |                         |                         |                         |                         |                         |
| f. "PAV" means Pressurized Aging Vessel.  |                    |                         |                         |                         |                         |                         |



Performance based asphalt (PBA) binder shall conform to the following:

| PERFORMANCE BASED ASPHALT BINDER   |                    |                     |             |        |        |
|--|--------------------|---------------------|-------------|--------|--------|
| Property   | AASHTO Test Method | Specification Grade |             |        |        |
|  |                    | PBA 6a              | PBA 6a(mod) | PBA 6b | PBA 7  |
| Absolute Viscosity (60°C), Pa·s(x10 <sup>-1</sup> ) <sup>a</sup>           | T202               |                     |             |        |        |
| Original Binder, Minimum   |                    | 2000                | 2000        | 2000   | 1100   |
| RTFO Test Aged Residue <sup>b</sup> , Minimum                              |                    | 5000                | 5000        | 5000   | 3000   |
| Kinematic Viscosity (135°C), m <sup>2</sup> /s(x10 <sup>-6</sup> )         | T201               |                     |             |        |        |
| Original Binder, Maximum   |                    | 2000                | 2000        | 2000   | 2000   |
| RTFO Test Aged Residue, Minimum  |                    | 275                 | 275         | 275    | 275    |
| Absolute Viscosity Ratio (60°C), Maximum                                   | —                  |                     |             |        |        |
| RTFO Test Visc./Orig. Visc.  |                    | 4.0                 | 4.0         | 4.0    | 4.0    |
| Flash Point, Cleveland Open Cup, °C  | T48                |                     |             |        |        |
| Original Binder, Minimum   |                    | 232                 | 232         | 232    | 232    |
| Mass Loss After RTFO Test, %   | T240               | 0.60                | 0.60        | 0.60   | 0.60   |
| Solubility in Trichloroethylene, % <sup>c</sup>                            | T44                |                     |             |        |        |
| Original Binder, Minimum   |                    | Report              | Report      | Report | Report |
| Ductility (25°C, 5 cm/min), cm   | T51                |                     |             |        |        |
| RTFO Test Aged Residue <sup>b</sup> , Minimum                              |                    | 60                  | 60          | 60     | 75     |
| On RTFO Test Aged Residue, °C  |                    |                     |             |        |        |
| 1 to 10 rad/sec: SSD <sup>e</sup> ≥ 0 and Phase Angle (at 1 rad/sec) < 72° |                    | —                   | 35          | —      | —      |
| On Residue from:   | R28                |                     |             |        |        |
| PAV <sup>g</sup> at temp., °C  |                    | 100                 | 100         | 100    | 110    |
| Or Residue from Tilt Oven <sup>f</sup> (@113°C), hours                     |                    | 36                  | 36          | 36     | 72     |
| <sup>e</sup> SSD ≥ -115(SSV)-50.6, °C                                      |                    | —                   | —           | —      | 25     |
| Stiffness,   | T313               |                     |             |        |        |
| Test Temperature, °C   |                    | -24                 | -24         | -30    | -6     |
| Maximum S-value, MPa   |                    | 300                 | 300         | 300    | 300    |
| Minimum M-value  |                    | 0.300               | 0.300       | 0.300  | 0.300  |

Notes:

- Absolute viscosity (60°C) will be determined at one sec<sup>-1</sup> using ASTM Designation: D 4957 with Asphalt Institute vacuum capillary viscometers.
- "RTFO Test Aged Residue" means the asphaltic residue obtained using the Rolling Thin Film Oven Test (RTFO Test), AASHTO Test Method T240 or ASTM Designation: D 2827.
- There is no requirement; however results of the test shall be part of the copy of test results furnished with the Certificate of Compliance.
- "Residue from Tilt Oven" means the asphalt obtained using California Test 374, Method B, "Method for Determining Asphalt Durability Using the California Tilt-Oven Durability Test."
- "SSD" means Shear Susceptibility of Delta; "SSV" means Shear Susceptibility of Viscosity.
- California Test 381.
- "PAV" means Pressurized Aging Vessel.



**202-2 EMULSIFIED ASPHALT**

Emulsified asphalts shall conform to the requirements of Section 94, "Asphaltic Emulsions," of the State Specifications and shall be of the type(s) shown for the following uses:

|                              |                  |    |                   |
|------------------------------|------------------|----|-------------------|
| Fog Seals:                   | SS1h             | or | CSS1h             |
| Tack Coats and Paint Binder: | PG 64-10 or SS1h | or | PG 64-16 or CSS1h |
| Slurry Seals:                | CSS1h            |    |                   |

Test reports and certification shall be made available upon request by the City Engineer. Fog seals and tack coats shall be emulsified asphalt, proportioned 50 percent asphalt and 50 percent water.

Bikepath seal coat shall be a cold applied composition of a refined petroleum asphalt emulsion, mineral fibers and inert fillers. Asphalt emulsion shall not be the clay type. An acceptable product is "OVER KOTE," as manufactured by Reed & Graham, Inc., or approved equal.

**202-3 JOINT SEALANT FOR CONCRETE PIPE**

Rubber-based joint sealant shall conform to the provisions of ASTM C990, rope form. The joint sealant shall be such that pre-heating of the sealant or surfaces will not be required during cold weather application. A compatible joint primer adhesive shall be supplied by the joint sealant manufacturer; when required. An approved joint sealant material is Kent Seal No. 2.

## **SECTION 203 PIPE AND RELATED MATERIAL**

### **203-1 PVC UNDERDRAIN PIPE**

All pipe and pipe fittings for street underdrains shall be slotted PVC pipe (smooth wall) conforming to State Specification Section 68-1.02K "Perforated Plastic Pipe." Corrugated plastic pipe will not be allowed.

### **203-2 STORM DRAIN PIPE**

#### **203-2.1 NON-REINFORCED CONCRETE PIPE**

Non-reinforced concrete pipe shall be Class III concrete pipe conforming to ASTM C14. Storm drain pipe, which is 12 inches in inside diameter or smaller, may be non-reinforced.

#### **203-2.2 REINFORCED CONCRETE PIPE**

Reinforced concrete drainage pipe shall conform to ASTM C76. All storm drain pipes, which are 15 inches in inside diameter or larger shall be reinforced concrete pipe. Any storm drain pipe which is 24 inches in inside diameter or larger, may be cast-in-place concrete pipe. The Class (i.e., I, II, III, IV, or V) of reinforced concrete pipe shall be as specified in the Special Provisions or as shown on the Project Plans.

#### **203-2.3 CONCRETE FOR CAST-IN-PLACE CONCRETE PIPE**

Concrete for cast-in-place concrete pipe shall be Class "A" conforming to the provisions of Section 90, "Portland Cement Concrete," of the State Specifications, except as herein modified. Concrete mixes shall be designed to attain a strength at 28 days of at least 3,000 psi. The slump shall be between one and three inches. The maximum aggregate size shall not exceed one-third the minimum wall thickness. At the option of the Contractor, an air-entraining admixture may be used, conforming to the provisions of Section 303-1.3, "Admixtures."

#### **203-2.4 PVC STORM DRAIN PIPE**

PVC storm drain pipe is only allowed in publicly owned or dedicated non-roadway areas of parks, greenbelts and other open spaces areas.

All pipe and fittings for PVC (polyvinyl chloride) pipe shall meet the requirements of ASTM D3034, minimum SDR 35, either gasket or solvent welded joints.

**203-2.5 CLAY STORM DRAIN PIPE**

Vitrified clay pipe (VCP) for use in storm drain applications shall comply with Section 203-3.1 herein.

**203-2.6 ASBESTOS CEMENT STORM DRAINAGE PIPE**

Asbestos cement storm drainage pipe shall not be used.

Procedures for removal of asbestos cement pipe shall comply with all local, national, and federal regulations pertaining to asbestos-containing products.

**203-3 SEWER PIPE**

Unless noted on the Plans, all sewer lines shall be vitrified clay pipe (VCP).

**203-3.1 VITRIFIED CLAY PIPE**

Vitrified clay sewer pipe shall conform to ASTM C700. Unless otherwise specified or approved by the City Engineer, extra strength bell and spigot pipe shall be used. Requests to use other than bell and spigot pipe shall be submitted to the City Engineer for approval, prior to the beginning of work. The clay pipe shall not be dipped in a solution to enhance air pressure tests.

Each spigot shall have a reference mark to facilitate pipe assembly. The gasket shall be contained in a machined groove on the pipe spigot such that when compressed the gasket will not displace and will form a positive seal. All rubber gaskets shall be stored in a cool, well ventilated place and not be exposed to oils, fuels, petroleum, solvents, or direct sunlight. The gasket shall meet all requirements of ASTM F477. Pipe lubricant shall be listed with the National Sanitation Foundation. Solvent cement joints are strictly prohibited.

Fittings shall conform to ASTM C700.

**203-3.1.1 COMPRESSION JOINTS**

Compression joints for vitrified clay pipe shall conform to ASTM C425. Lubricant shall be as recommended by the manufacturer.

Compression joints will be allowed only in those sizes (i.e., six inches inside diameter through 12" inside diameter) for which all of the required elements are available. The compression joint requirements contained herein apply to mains and laterals.

Compression joints for plain-end pipe shall consist of an elastomeric sleeve incorporating stainless steel take-up clamps. The joint shall have a stainless steel shear ring, with stop ring or tabs to properly position the pipe with respect to the joint. The joint shall be factory attached on one end of the pipe.



The use of compression joints will be allowed only as approved by the City Engineer on a case-by-case basis.

### **203-3.1.2 REPAIR OR SLEEVE COUPLINGS**

Repair or sleeve couplings shall be the compression joint type and shall conform to ASTM C425. Lubricant shall be as recommended by the manufacturer. The coupling shall have a stainless steel shear ring, and all take up clamps shall be stainless steel.

Reinforced concrete collars, per Standard Plan 401-2, shall be used when stainless steel sleeves are not otherwise available (for pipes larger than 12 inches in nominal inside diameter).

### **203-3.2 DUCTILE IRON PIPE SEWER LATERALS**

Where the joint trench is located beyond the sidewalk (see Standard Plan 201-6), ductile iron pipe (DIP) shall be used for sewer laterals. All other use of DIP for sewer lines shall be on a case-by-case basis as approved by the City Engineer.

Ductile iron pipe for sewer laterals shall comply with Section 203-4.2 herein.

### **203-3.3 PVC SEWER FORCE MAINS**

PVC pipe for sewer force mains shall comply with Section 203-4.1 herein except pipe shall be green in color.

### **203-4 WATER PIPE**

Unless noted on the Plans, all water line 4 inches in diameter and larger shall be polyvinyl chloride (PVC). Ductile iron pipe (DIP) may be used on a case-by-case basis as approved by the City Engineer.

All underground metal (ductile iron, valves, fittings, copper, brass, etc.) shall be wrapped in 8-mils minimum thickness polyethylene encasement per AWWA C105 with ends taped off with vinyl pipe wrap tape. Damaged or scratched surfaces with epoxy coating shall be repaired with an epoxy kit per manufacturer's recommendations and to the satisfaction of the City Engineer prior to wrapping. Otherwise, the damaged item shall be replaced.

Insulating kits shall be installed at transitions between dissimilar metal pipe and as required by the City Engineer. Insulating flange gaskets shall be ASME B16.21 insulation flange kits, Type E Full Face Gasket with two-side insulation as manufactured by Calpico, Inc. or approved equal.

All pipe, valves, and fittings shall be certified as suitable for contact with drinking water by an ANSI accredited organization in accordance with ANSI/NSF Standard 61, Drinking Water Systems Components – Health Effects



### **203-4.1 POLYVINYL CHLORIDE (PVC) PIPE**

All PVC water pipe and fittings shall be manufactured in accordance with AWWA C900 or AWWA C905 with cast-iron-pipe equivalent (CI) outside diameter (OD) dimensions.

Thickness shall be a minimum of DR18 (Class 150) for AWWA C900 pipe and DR25 (Class 165) for AWWA C905 pipe.

Minimum thickness through the pipe bell and ring seating areas shall be as specified in AWWA C900 or C905.

Pipe shall be furnished in 20-foot sections. PVC water pipe shall be blue in color with black stencil and shall have been manufactured within 18 months of installation.

The name of manufacturer, year in which the pipe was produced, size, class or nominal thickness, spigot insertion depth, and National Sanitation Foundation (NSF) seal shall be shown on each pipe. When PVC pipe is to be connected to a valve or fitting with an elastomeric gasket joint, a new insertion line must be marked on the pipe prior to installation.

Prior to delivery, manufacturer/supplier shall submit a written "Certificate of Compliance" that pipe to be supplied meets all applicable AWWA and ASTM standards.

Pipe may be rejected for failure to comply with any requirement of this specification, including damage from heat or sun exposure.

Approved PVC Pressure Pipe manufacturers include: CertainTeed Certa Lock, Diamond Plastics Corporation, J-M Eagle, Pacific Western Pipe, Vinyl Tech-White Knight, Pressure – Flex Pipe, or approved equals.

#### **203-4.1.1 PVC PIPE JOINTS**

Pipe joints shall be gasketed, push-on type with an integral bell end. The bell ends shall be integral thickened bell end or integral sleeve-reinforced bell end. The bell end joints shall have a minimum wall thickness of the bell or sleeve-reinforced bell equal at all points to the standard dimension ratio requirements for the pipe. The minimum wall thickness in the ring groove and bell-entry sections shall be equal to or exceed the minimum wall thickness of the pipe barrel.

Gaskets shall meet the requirements of ASTM F477 and be part of a complete pipe section and purchased as such. Lubricant and its application shall be as recommended by the pipe or fitting manufacturer and shall not adversely affect the potable qualities of the water to be transported. Spray-on lubricants shall not be permitted. The gasketed joint shall meet the laboratory performance requirements specified in ASTM D3139. Gaskets shall be of the rieber style.

Pipe restraint shall be achieved through the use of thrust blocks. Use of other PVC pressure pipe restraint systems shall be approved by the City Engineer on a case-by-case basis and shall be Romac 611 Restraint, EBAA Series 1500, or approved equal.

**203-4.1.2 PVC TO DUCTILE IRON TRANSITION**

Transitions between PVC and ductile iron shall be made by inserting a PVC pipe spigot into a ductile iron pipe bell. The PVC bevel on the spigot shall be cut off, leaving no more than a 1/2-inch taper. A City inspector shall be present to witness this process.

**203-4.2 DUCTILE IRON**

Ductile iron pipe shall be manufactured in accordance with AWWA C151. Pipe wall thickness shall be determined in accordance with AWWA C150, using working pressure of 200 psi.

All ductile iron water pipe and fittings shall have a standard thickness cement lining, applied in accordance with the requirements of AWWA C104. The weight, class or nominal thickness, spigot insertion depth, and casting period shall be shown on each pipe. The manufacturer's mark, the year in which the pipe was produced, and the letters "D.I." or "DUCTILE" shall be cast or stamped on the pipe.

Pipe shall be encased with polyethylene bags conforming to AWWA C105. Polyethylene-encased pipe shall be bedded and backfilled with sand to 12 inches above the crown of pipe.

At the direction of the City Engineer, the Contractor shall repair damages to the polyethylene encasement as described within AWWA C105 or shall replace all damaged polyethylene film sections.

Cathodic protection shall be designed by a qualified corrosion protection engineer.

DIP cuts shall be coated with an approved bituminous material.

Minimum length of pipe for installation shall be 2 feet.

**203-4.2.1 DUCTILE IRON PIPE JOINTS**

Joints shall be push-on or mechanical type with rubber gaskets unless otherwise specified. All ductile iron pipe joints shall be manufactured in accordance with the requirements of AWWA C111. The lubricant and its application shall be as recommended by the pipe manufacturer and shall not adversely affect the potable qualities of the water to be transported. Spray-on lubricants shall not be permitted.

Pipe restraint shall be achieved through the use of thrust blocks. Use of other restraint systems shall be approved by the City Engineer on a case-by-case basis and shall be as follows. Restrained joints for ductile iron pipe and ductile iron fittings shall be externally restrained mechanical joints (such as EBAA Megalug or approved equal), manufacturer's push-on restrained joints (such as Field Lock Gaskets (3 inches through 12 inches diameter only) American FlexRing, TR Flex by U.S. Pipe, or approved equal), or mechanical rodding.

All fittings, glands, etc shall be made in USA.



**203-4.3 PIPE FITTINGS**

All bends, tees, crosses, and other fittings for use with either ductile iron or PVC pipe shall be ductile iron. Flanged fittings shall be manufactured in accordance with AWWA C110. Mechanical joint fittings shall be manufactured in accordance with AWWA C153. All fittings except tapping sleeves shall either be factory fusion bonded epoxy lined and coated in accordance with AWWA C116 or double cement-lined and coated with an asphaltic seal coat in accordance with AWWA C104. Fittings shall have push-on, mechanical joints or flanged ends. Fittings shall be wrapped and sealed in accordance with these Construction Standards. All fittings shall be made in USA.

Fittings and accessories for push-on or mechanical type joints shall conform to AWWA C153. All cross and tee fittings shall have flanged ends.

The Contractor may use a ductile iron mechanical joint flange adapter designed for AWWA C900 pipe with connecting PVC Pressure Pipe to flanged fittings or flanged valves. Pipe ends must be cut smooth and square with no bevel. The joint shall be restrained to the PVC pipe using an approved restraint method.

Fittings shall be rated for a minimum 250 psi working pressure.

All bolts, nuts, and washers installed below grade shall be Type 304 stainless steel. Teflon anti-seize compound shall be used on all bolt and tie rod threads.

**203-4.4 CORROSION RESISTANT FASTENINGS**

All nuts, bolts and washers for underground valves, fittings and appurtenances except T-bolts shall be Type 304 stainless steel. Teflon anti-seize compound shall be used on all bolt and tie rod threads.

**203-4.5 LOCATING WIRE**

A continuous number 10 insulated locating wire shall be attached to non-metallic mains, service lines and appurtenances per the Standard Plans and the following:

1. Locating wire shall be continuous between mainline valve boxes and fire hydrants. It shall be attached to the top of the pipe with 10-mil vinyl tape every 5 feet.
2. Locating wires through valve boxes shall be placed outside of riser, but inside the box. Locating wire shall loop within the valve box with 18 inches of slack wire.
3. Locating wire in manholes and vaults shall be attached inside the facility within one foot of the rim.
4. Wire splices shall be located above ground and inside of valve boxes and made per Standard Plan 101-3.

5. Insulation color shall be white for water, green for sewer, or purple for reclaimed water.

### **203-4.6 MARKING TAPE**

A 12-inch wide, blue plastic non-detectable water pipe marking tape, marked "Buried Water Main Below," shall be placed in all main line and large diameter (4" and larger) service line trenches, 18 to 24 inches above the pipe.

Where a water main and recycled water main intersect, the plastic marking tape shall also be attached to the top of the pipe with nylon tie-wrap banded around the warning tape and the pipe every five feet on center. The warning tape shall extend to the nearest valves located on each side of said intersection.

Mains in unpaved areas shall be marked every 150 lineal feet with a blue composite utility marker having a decal stating: "Caution Water Pipeline." Appurtenances (valves, ARVs, test stations, etc.) and angle points shall also be marked. Mains in landscaped areas shall be delineated with a brass marker set in an 8-inch concrete cylinder 4 inches above finished grade. The brass marker shall state "City of Davis Water Main."

Approved manufacturers and materials include: Calpico Inc. (Tracer Tape-Non-Detectable 12" width), Reef Industries Inc., Terra Tape Extra Stretch 450 Material, or approved equal.

### **203-5 VALVES**

All valves shall be gate type, resilient seat, unless otherwise specified in the Special Provisions or the Project Plans. All bolts used in the body of the valve or an integral part of the valve shall be stainless steel, except T-bolts. Teflon anti-seize compound shall be used on all bolt threads.

Restraint shall be provided on both sides of all mid-block valves (those valves not flanged to a tee or cross). In addition, short sections of pipe shall not be allowed adjacent to mid-block valves; a full length of pipe shall be connected to each side of each mid-block valve.

#### **203-5.1 BUTTERFLY VALVES**

Butterfly Valves shall be used only when specifically approved by the City Engineer.

Butterfly Valves shall be manufactured in accordance with the requirements of AWWA C504, latest revision. All valves shall open left (counterclockwise) with a 2" square cast iron operating nut. All valves shall be coated on the inside and the outside surfaces with a factory applied fusion bonded epoxy. When installed in the street, the operating nut shall be installed toward the centerline of the street.

All bolts used in the body of the valve or an integral part of the valve shall be stainless steel, except T-bolts.



## **203-5.2 GATE VALVES**

Gate valves shall be installed on all water mains, services, or fire hydrant leaders, four inches in inside diameter or larger.

Gate valves shall be manufactured in accordance with the requirements of AWWA C509 or AWWA C515, for resilient-seated gate valves. All valves shall be non-rising stem (NRS), open left (counterclockwise) and have a standard 2" square cast iron operating nut. All valves shall be coated on the inside and the outside surfaces with a factory applied fusion bonded epoxy.

All bolts used in the body of the valve or an integral part of the valve shall be stainless steel, except for T-bolts.

### **203-5.2.1 RESILIENT SEATED TAPPING VALVES**

The valve shall be manufactured in accordance with the requirements of AWWA C509 and include the following details: All inside ferrous surfaces of the valve are to be protected by a factory applied fusion bonded epoxy coating. The tapping valves shall have a raised pilot on one end of the valve to assure proper alignment.

### **203-5.2.2 STAINLESS STEEL TAPPING SLEEVES**

All tapping sleeves shall be 304 stainless steel with flange gasket made of SBR (silicon based rubber), glued onto the face of the flange. Nuts and bolts shall be 5/8" NC (national coarse) threads, 304 stainless steel with Teflon coated threads.

## **203-5.3 VALVE EXTENSION**

If distance from top of valve to finish grade is more than 48 inches, extension of valve riser shall be required to meet a minimum distance of 48 inches.

## **203-6 FIRE HYDRANTS**

Fire hydrants shall be "steamer," traffic type, dry barrel and supplied with factory applied bright yellow paint. They shall conform to the provisions of AWWA C502. The internal elements shall be all bronze.

See Standard Plan #101-1, "Fire Hydrant," for other installation details.

### **203-6.1 MAIN VALVE AND BODY**

The fire hydrants shall have a valve opening of 4-1/2" diameter. The valve shall open left (counterclockwise) and shall have a standard 1-1/2" pentagon operating nut.

The bury shall be 4' in length and shall connect to the lateral using a mechanical joint. The drain hole shall be tapped and plugged with a threaded brass plug.

**203-6.2 OUTLET CONNECTIONS**

The outlets shall consist of one each 4-1/2" in diameter pumper connection and two each 2-1/2" diameter hose connections. The cap nuts shall be the same size and shape as the operating nut. All outlet connection threads shall conform to National Standard hose coupling specifications. Chains shall be provided to attach the outlet caps to the hydrant body.

**203-6.3 APPROVED MANUFACTURERS MODELS**

Fire hydrants shall be one of the following approved models:

| APPROVED FIRE HYDRANTS |                 |
|------------------------|-----------------|
| Manufacturer           | Model           |
| American-Darling       | B-84-B-5        |
| Mueller                | Centurion A-423 |
| Kennedy                | Guardian K81D   |

**203-6.4 PAVEMENT MARKERS**

Pavement markers for fire hydrants shall be blue two-way reflectorized, conforming to the requirements of Section 85, "Pavement Markers," of the State Specifications. Adhesive shall be Rapid Set Type.

**203-6.5 PAINT**

All new fire hydrants shall be supplied with a factory applied bright yellow paint. When a fire hydrant needs to be repainted, the paint shall be Gloss Enamel, Break Through 70-46 low VOC "Safety Yellow", as manufactured by Vanex, Inc., or approved equal.

**203-7 WATER VALVE BOXES**

All valve boxes in streets and other traffic areas shall be designed to H-20 loading conditions and shall be of precast concrete with a cast iron face and cast iron traffic lid marked "WATER." Water valve boxes shall be "Brooks" #3RT, "Christy" #G5, "Bes" #G-5, or approved equal.

**203-8 WATER SERVICES**

Water services, fittings and valves shall conform to the requirements of AWWA C800, and as described below. Services shall be continuous from the main line to the service box.

All service fittings shall be certified as suitable for contact with drinking water by an ANSI accredited organization in accordance with ANSI/NSF Standard 61, Drinking Water Systems Components – Health Effects.

### 203-8.1 SIZES AND PIPE TYPES

The minimum size of water service shall be 1" in diameter. The minimum size of water service for a single family dwelling unit with fire sprinklers shall be 1-1/2" in diameter. The minimum size of common service serving more than one single family dwelling unit shall be 2" in diameter. Larger size services may be required by the City Engineer based on the intended type of user and the number of dwelling units or other users.

Two and one-half inches in diameter, 3" in diameter and 3-1/2" in diameter services are not allowed. When the demand constraints require a service larger than 2" in diameter and smaller than 4" in diameter, then a 4" in diameter service will be the minimum required size.

All services 4" in diameter and larger shall be PVC water pipe as specified in Section 203-4.

All underground metal services shall be protected from corrosion by wrapping or sleeving in eight (8) mil polyethylene.

#### 203-8.1.1 COPPER SERVICES

Copper water services shall be Type K seamless, annealed copper water tubing. All copper tubing shall conform to ASTM B88.

Copper shall be grade UNS-C12200. For diameters ranging from 3/4" to 1", use Type K Roll Soft Copper. For diameters ranging from 1.5" to 2", use Type K Soft 20' Sticks.

Approved manufacturers include: Cambridge-Lee, Mueller Industries, or approved equal.

### 203-8.2 SADDLES

Saddles shall be installed on water mains for service connections between 1" in diameter and 2" in diameter, inclusive. Service connections 4" or larger shall consist of a tee, gate valve (R/S type) and other appropriate fittings.

Saddles for PVC pipe shall be all bronze with Iron Pipe threads.

| PVC PRESSURE PIPE SADDLES |              |          |
|---------------------------|--------------|----------|
| Pipe Size                 | Manufacturer | Part No. |
| 4" – 12"                  | Jones        | J-996    |
| 4"                        | Mueller      | H-13490  |
| 6"                        | Mueller      | H-13491  |
| 8"                        | Mueller      | H-13492  |
| 10"                       | Mueller      | H-13493  |
| 12"                       | Mueller      | H-13494  |



Saddles for ductile iron pipe shall be a full circumference stainless steel clamp with an integral stainless steel service outlet, stainless steel bolts, and a full pipe circumference neoprene gasket as shown in Standard Plan 101-5.

**203-8.3 BRAZING**

Brazing compound (solder) for use with copper water services shall be SILVALOY-15 BRAZING ROD (80 percent Copper, 15 percent Silver, five percent Phosphor), as manufactured by Wolverine Joining Technologies, or approved equal. It shall have not more than 0.2 percent (by weight) of lead.

**203-8.4 BACKFLOW PREVENTION**

A backflow prevention assembly shall be provided on each water service, when required by the provisions of the Davis Municipal Code, 1971, as amended. The required type of backflow preventer shall be provided in accordance with the requirements of said Ordinance and in accordance with the Rules and Regulations adopted pursuant thereto. A copy of the Rules and Regulations can be obtained at the Office of the Public Works Department.

When a backflow device is required to be installed, after the installation and prior to the approval and acceptance by the Public Works Department, an inspection must be performed by a City of Davis Certified Backflow Tester.

**203-8.5 CORPORATION STOPS**

Corporation Stops shall be ball valve type for use in potable water systems. They shall consist of a bronze body, bronze tee-head and stem, spherical fluorocarbon coated brass ball with molded Buna-N rubber seats, double Buna-N o-rings on stem, bronze ring to lock stem to body, and integral ends for fastening to pipe. The valve shall be watertight at all pressures, shall be easy turning, non-binding, and shall have minimal pressure loss at operating pressures and flow.

| <b>APPROVED CORPORATION STOPS</b> |   |                                  |   |
|-----------------------------------|---|----------------------------------|---|
| <b>Manufacturer</b>               | <b>1" Class<br/>on Ductile Iron Mains</b> | <b>1" Class<br/>on PVC Mains</b> | <b>1-1/2" and 2" Class<br/>on All Mains</b> |
| McDonald                          | 74701BT                                   | 74704BT                          | 74704BT                                     |
| Ford                              | FB1000-4-Q                                | FB1100-4-Q                       | FB1100-6-Q<br>FB1100-7-Q                    |
| Jones                             | J1937SG                                   | J1935SG                          | J1935SG                                     |
| Mueller                           | B-25008-1                                 | B-25028-1                        | B-25028-12<br>B-25028-2                     |

Direct service taps will not be allowed; taps 2-inches and smaller shall use a saddle. All 1-1/2" and 2" corporation stops shall be Iron Pipe thread by compression.



**203-8.6 ANGLE METER STOPS**

Angle Meter Stops shall be full port ball valve type for use in potable water systems. They shall consist of a bronze body, bronze lockable tee-head and stem, spherical fluorocarbon coated brass ball with molded Buna-N rubber seats, double Buna-N o-rings on stem, bronze ring to lock stem to body, and integral ends for fastening to pipe. The valve shall be watertight at all pressures, shall be easy turning, non-binding, and shall have minimal pressure loss at operating pressure and flow. The angle between the pipe connection and the meter connection shall be 90°. See Standard Plan 101-6 for approved makes and model numbers.

The 1" stops shall be compression on the pipe side and meter coupling on the meter side, or if alignment between couplings is straight, IPT (iron pipe thread) may be used. The 1-1/2" and 2" stops shall be female iron pipe thread on the pipe side and bolted flange on the meter side. A male iron pipe thread by compression joint adapter shall be provided for use on the service side of the 1-1/2" and 2" stops. The use of connections on the pipe side, other than compression joint, requires advance approval of the City Engineer.

Meter adapters and connectors as manufactured by the manufacturer of the angle meter stop shall be used when necessary to connect meters, angle stops and pipes of dissimilar sizes.

**203-8.7 WATER METERS**

All Water Meters for 3/4", 1", and 1-1/2" diameter services shall conform to the requirements of AWWA C700, for cold water displacement type water meters. Meter type for 2" and larger water meters will be determined by the City Engineer and may be displacement, turbine or compound. All meters shall be designed and constructed for measuring potable water, similar to the chemical makeup of water typically supplied through the City of Davis system.

All meters supplied to the City shall accurately record and display  $100 \pm 1.5$  percent of the actual flow.

**203-8.7.1 CONSTRUCTION**

All materials used in the meter construction shall be designed to resist the aggressive properties of Davis water. The meter maincase and cover plate (top or bottom) shall be constructed of bronze. The measuring chamber, piston and/or rotor shall be constructed of or lined with corrosion resistant thermoplastic material. Bolt holes shall be integrally cast with the maincase. Flange make up bolts, nuts and washers, casing bolts and miscellaneous trim shall be stainless steel.

**203-8.7.2 REGISTER**

The meter register shall be a Sensus Metering Systems Touch Read Pit Lid (TR/PL) model or approved equal. It shall be a hermetically sealed, tamperproof unit. It shall be permanently sealed against the intrusion of dirt and moisture. There shall be no penetrations of the exterior enclosure of the unit. The sealed register unit shall be provided with a manufacturer's guarantee of 10 years for the register and 25 years for the main case.

The gear mechanism shall accurately reduce the movement of the magnetic drive unit into the appropriate units of measure. The dial shall display water flow in units of cubic feet or multiples thereof. The sweep shall display in cubic feet per revolution or multiples thereof and shall be evenly divided into 10 increments.

### **203-8.7.3 MAGNETIC DRIVE**

All meters shall use a magnetic drive mechanism to transfer the action of the measuring piston or rotor into the register. The drive magnet shall be attached to the measuring piston or rotor. The driven magnet shall be inside of the sealed register. The only moving parts exposed to water shall be the measuring piston or rotor and the drive magnet.

### **203-8.7.4 STRAIGHTENING VANES**

Straightening vanes shall be provided on all turbine type meters. They shall be placed upstream of the rotor and shall eliminate or minimize the turbulence caused by piping arrangements. An adjusting vane shall also be provided for calibration purposes.

### **203-8.7.5 APPROVED MANUFACTURERS MODELS**

Displacement type water meters shall be as manufactured by Sensus Metering Systems or approved equal. Turbine type water meters shall be Series "W" Turbo Meters, as manufactured by Sensus Metering Systems or approved equal. Compound meters shall be Sensus SRH or approved equal.

### **203-8.8 BOXES FOR WATER METERS**

Boxes for Water Meters shall be reinforced concrete or plastic, as specified herein and on Standard Plan 101-6. Boxes which will be located in an area where vehicles will travel (e.g. driveways) shall be reinforced concrete.

### **203-8.9 WATER METER LABELS**

Labels shall be provided for water meters when more than one meter is installed to serve one parcel. Label materials shall be stainless steel, brass or other non-corrodible metal. "Building," "Landscape," or other appropriate wording shall be stamped or engraved in 1/4" high letters. The label shall be attached to the meter or piping with plastic ties commonly used for bundling electrical wires.

### **203-9 BLOWOFF VALVES**

End of main blowoffs shall be constructed at the end of all temporary dead end runs.

Valves used on waterline blowoffs per Standard Plan 101-4 shall be ball valve type, 2" size or inside diameter, and shall be one of the following:

| <b>BLOWOFF VALVES</b> |              |
|-----------------------|--------------|
| <b>Manufacturer</b>   | <b>Model</b> |
| Ford                  | B11-777      |
| Jones                 | J-1900       |

Eccentric reducer shall be installed such that 2" FIPT is located along the invert of the pipeline. Eccentric Reducer shall be Tyler Union or approved equal.

## **203-10 MAINTENANCE HOLES**

### **203-10.1 STANDARD MAINTENANCE HOLES (SANITARY AND STORM DRAIN)**

Except as otherwise required by the contract documents, all maintenance hole sections (barrels, cones, flat-tops, etc.) shall be precast reinforced concrete sections conforming to ASTM C478. All flat-top maintenance holes shall also be designed to withstand the imposed loading due to an AASHTO H20-S16 highway load. All other details shall conform to Standard Drawing No. 201-2, "Maintenance Hole Details."

### **203-10.2 LINED SANITARY SEWER MAINTENANCE HOLES**

When required by the City Engineer, sanitary sewer maintenance holes shall be constructed of materials impervious to hydrogen sulfide attack.



**SECTION 204  
MISCELLANEOUS METAL AND CASTINGS**

**204-1 METAL RAILINGS AND BARRIERS**

Metal railings and barriers shall conform to the requirements of Section 83 entitled, "Railings and Barriers" of the State Specifications.

**204-2 CHAIN LINK FENCE**

Chain link fence shall conform to the requirements of Section 80, "Fences" of the State Specifications.

**204-3 MAINTENANCE HOLE LIDS AND CASTINGS**

Maintenance hole lids and castings shall conform to City of Davis Standard Plan 201-2, "Maintenance Hole Details."

**204-4 MONUMENT LIDS AND CASTINGS**

Monument lids and castings shall conform to City of Davis Standard Plan 301-5, "Monument Box."



## **SECTION 205 STRIPING AND TRAFFIC SIGNING MATERIALS**

### **205-1 TRAFFIC PAINT AND RELATED MATERIALS**

Unless otherwise specified herein, all materials shall conform to the provisions of the various Sections of the State Specifications.

### **205-2 TRAFFIC PAINT**

#### **205-2.1 GENERAL**

Paint shall be homogeneous, free of contaminants, and of a consistency suitable for the use for which it is specified. The pigment shall be finely ground and properly dispersed in the vehicle according to the requirements of the paint. This dispersion shall be of such nature that the pigment does not settle appreciably, does not cake or thicken in the container, or become granular or curdled.

Paint and paint materials shall be delivered to the job site in new, unopened, air-tight containers, appropriately identified with the manufacturer's name, date of manufacture, type of paint or paint material, State Specification number, and lot or batch number. The containers and labeling shall meet all applicable U.S. Department of Transportation and Interstate Commerce Commission regulations. Concerning the contents, each container shall be labeled with such warnings or precautions as are required by State and Federal laws and regulations.

Precautions in the handling and the application of paints shall be in accordance with all applicable occupational safety and health standards, rules, regulations and orders established by the State of California.

Paints shall be furnished formulated ready for application and no thinning will be allowed. Paints shall be water borne only, solvent borne paints are not allowed.

#### **205-2.2 WHITE, YELLOW, AND BLACK PAINT**

White, yellow, and black paint shall conform to the provisions of State Specification No. PTWB-01, Water Borne.

#### **205-2.3 GLASS BEADS**

Glass beads shall conform to the provisions of State Specification No. 8010-004, Type II.

#### **205-2.4 PAVEMENT MESSAGES**

Stencils used for pavement messages shall be furnished by the City of Davis. All stencils shall be cleaned and returned in good condition.

**205-3 TRAFFIC SIGNS**

**205-3.1 GENERAL**

All traffic signs specified by a letter and number code combination shall conform to the Traffic Manual, State Department of Transportation. The design details of the various signs shall conform to the California Manual on Uniform Traffic Control Devices.

Where more than one size of sign is available, the Contractor shall verify the size with the City Engineer, prior to ordering.

All speed limit signs (R2) shall be 30 inches in height and 24 inches in width.

**205-3.2 METAL POSTS**

All metal pipe shall be minimum two inches nominal size, galvanized iron, Schedule 40, conforming to the provisions of ASTM A53.

**205-3.3 WOOD POSTS**

All wood posts shall be minimum four inches by four inches, nominal size, and shall be construction grade redwood, all-heart.

**205-3.4 MISCELLANEOUS FASTENING HARDWARE**

All miscellaneous fastening hardware and fittings shall be standard commercial quality, hot-dip galvanized after fabrication. Straps and saddle brackets for mounting signs on electroliers and traffic signal standards shall be stainless steel.

## SECTION 206 STREETLIGHT MATERIALS

### 206-1 GENERAL

#### 206-1.1 REGULATIONS AND CODES

All electrical equipment shall conform to the standards of the National Electrical Manufacturers Association (NEMA), the Underwriters' Laboratories, Inc. (UL), or the Electronic Industries Association (EIA), wherever applicable. In addition to the requirements of the Plans, these Specifications, and the Special Provisions, all materials and workmanship shall conform to the requirements of the National Electrical Code, hereinafter referred to as the Code; California Administrative Code, Title 8, Subchapter 5, Electrical Safety Orders; Rules and Overhead Electrical Line Construction, General Order No. 95 and Rules for Construction of Underground Electrical Supply and Communication Systems, General Order No. 128, of the Public Utilities Commission; Standards of the American Society for Testing and Materials (ASTM); American National Standards Institute (ANSI), and any local ordinances which may apply.

All separate electrical components shall be UL approved. Major control assemblies shall also be UL approved as required by the Project Specifications.

#### 206-1.2 DEFINITIONS

**STANDARD STREETLIGHT** shall mean a tapered steel pole and an arm extending from the pole, to which the luminaire is mounted.

**POST MOUNTED OR POST TOP STREETLIGHT** shall mean a tapered steel pole with the luminaire mounted on top of the pole.

**ELECTROLIER OR STREETLIGHT** shall mean the entire pole, mounting arm, luminaire, wiring, foundation and miscellaneous appurtenances, complete in place.

**LUMINAIRE** shall mean the lighting fixture, supplied as a complete unit, which is attached to the streetlight pole, consisting of a housing, reflector, refractor, integral ballast, terminal strip and mounting device. The distribution type shall be as shown on the Plans.

#### 206-1.3 STANDARD PLANS

The following Standard Plans show additional details of required materials and approved manufacturer's products:



| STANDARD PLANS |   |
|----------------|---|
| Standard Plan  | Title   |
| 301-11         | Service Box Installation and Location Details for Street Lights |
| 301-12         | Streetlight Luminaires  |
| 301-13         | Standard Streetlight  |
| 301-14         | Post Top Streetlight  |

**206-2 HIGH PRESSURE SODIUM LUMINAIRES**

All streetlight luminaires shall be high pressure sodium of the sizes and types indicated on the Plans and as provided in these Specifications. The luminaires shall be 120 volt, AC, and mayor may not have photo-electrical receptacle.

All standard fixture luminaires of 70 watt size may have a reactor type ballast. All standard fixture luminaires of 100 watt size or larger and all sizes of post top mounted luminaires shall have a regulator type ballast.

All standard fixtures shall be General Electric M250R2, or approved equal. All standard light fixtures (luminaires, lens, shield, etc.) shall be full-cutoff. All post top fixtures shall be General Electric PM17 Series with Lexan refractor, or approved equal.

Photo-electric controls, when required, shall be General Electric 402G660, or approved equal.

**206-3 POLES**

All poles shall be tapered steel, fabricated from weldable grade hot rolled commercial quality carbon steel and hot-dip galvanized after fabrication per ASTM A123. The thickness shall be United States standard 11 gauge or 10 gauge, depending on material strength. Each pole shall be one-piece construction, cylindrical in cross-section, with a uniform taper from base to top.

The poles shall be supplied with a shop fabricated and welded anchor base plate. The baseplate shall have shop drilled holes for the anchor bolts. The anchor bolt holes shall provide for a plus or minus bolt adjustment of 1/2".

All poles shall have a shop fabricated handhole. The minimum size of opening for 'standard streetlight poles shall be 4" by 6-1/2". The minimum size of opening for post top streetlight poles shall be 2" by 4". The handhole opening shall be reinforced with a shop fabricated and welded steel lip. The handhole shall be provided with a removable raintight cover. The pole shall be provided with a grounding terminal, which shall be accessible from the handhole.

The standard streetlight poles shall have an arm to which the luminaire shall be attached. The luminaire arm attachment device shall be such that gravity will hold the arm in place, prior to permanently fastening with an appropriately sized bolt.



The pole manufacturer shall supply all anchor bolts, anchor bolt covers, anchor base cover, pole top cap, grounding terminal, conductor support device, and any other miscellaneous, mounting or fastening hardware.

Each pole shall be hot-dip galvanized after completion of all welding.

#### **206-4 CONDUIT**

All conduit and fittings shall be Underwriters' Laboratory (UL) listed and shall be one of the following:

##### **206-4.1 METAL CONDUIT**

Metal conduit shall be rigid steel tubing, and shall be hot-dip galvanized after fabrication. It shall not have any rough spots, blisters, scale, rust, or chipped or damaged galvanized coating. Each complete length shall bear the manufacturer's name and UL label.

##### **206-4.2 PLASTIC CONDUIT**

Plastic conduit and fittings shall be rigid polyvinyl chloride (PVC) pipe and shall be Schedule 40. Each complete length shall bear the manufacturer's name and UL label. The type of PVC cement shall conform to the manufacturer's recommendations.

#### **206-5 WIRING (CONDUCTORS)**

All wires shall be copper and shall have a moisture and heat resistant type of thermoplastic insulation (Type THW or THWN). All wires #8 American Wire gauge (AWG) and larger shall be stranded. Bonding (ground) wires may be uninsulated and shall be stranded when they are #8 AWG or larger. The City Engineer will approve all wiring materials prior to their incorporation into the work.

The minimum size for wires installed in conduits and within the light pole up to the in line fuse shall be #8 AWG. The minimum size for wires installed from the in line fuse to the luminaire shall be #12 AWG.

All conductors shall have clear, distinctive and permanent markings on the outer surface throughout the entire length, which indicate the manufacturer's name or trademark, insulation type letter designation, conductor size, and voltage rating. Conductor insulation shall be a solid color.

Ground rods shall be a minimum one-half inch in diameter and eight feet in length. Ground rod material shall be copper -clad steel.

**206-6 PULL BOXES**

All pull boxes, pull box extensions, and pull box covers, shall be precast reinforced concrete conforming to the State Specification 86-2.06, "Pull Boxes," #3-1/2 pull box. Boxes may be larger in size depending on the application.

Box covers shall be provided with two 3/8-inch brass hold down bolts with brass washers and nuts. Nuts shall be recessed below surface of the cover. The cover shall be marked "Streetlights." Where pull boxes are to be placed in areas subject to traffic loads, a steel cover of suitable design to withstand traffic loads shall be provided instead of the concrete cover.

Approved boxes are Christy N9 and Brooks #36.



# **PART THREE**

## **CONSTRUCTION METHODS**

### **SECTION 300**

#### **REMOVALS, EXCAVATION AND EARTHWORK**

#### **300-1 CLEARING AND GRUBBING**

##### **300-1.1 GENERAL**

This work shall consist of removing all natural and artificial objectionable material from the right-of-way, construction areas, road approaches and material sites within the right-of-way. Clearing and grubbing shall be performed in advance of grading operations and in accordance with the requirements herein specified, subject to erosion control requirements. Demolition of buildings and structures, other than foundations or slabs, shall be as specified in the Special Provisions or on the plans.

##### **300-1.2 CLEARING AND GRUBBING OPERATION**

Unless otherwise specified, the entire area of the project, to the widths specified below, shall be cleared and grubbed.

The area above the natural ground surface shall be cleared of all vegetable growth, such as trees, logs, upturned stumps, roots of downed trees, brush, grass, weeds, and all other objectionable material, within the following limits:

1. For streets, road and highway construction areas, including structures, frontage roads or streets, ramps, approaches, ditches and channels, and all other accessory roads and connections to be constructed, the clearing and grubbing shall extend to the outside excavation and embankment slope lines, except that where slopes are to be rounded, the areas shall extend to the outside limits of slope rounding.
2. Within the limits of clearing, all stumps, large roots, buried logs, and all other objectionable material shall be removed three feet below the existing ground surface or six feet below finished ground, whichever is deeper.

Trees and plants that are not to be removed shall be fully protected from injury by the Contractor at his expense.

##### **300-1.3 REMOVAL AND DISPOSAL OF MATERIALS**

All materials removed shall be disposed of outside of the right-of-way. The roadway and adjacent areas shall be left with a neat and finished appearance.

The removal of existing improvements shall conform to the following requirements:



1. BITUMINOUS PAVEMENT shall be removed to clean straight lines. Saw cutting shall be required to a minimum depth of one inch.
2. CONCRETE PAVEMENT shall be removed to neatly sawed edges. Saw cuts shall be made to a minimum depth of one and one-half inches. If a saw cut in concrete pavement falls within three feet of a construction joint, cold joint, expansion joint, or edge, the concrete shall be removed to the joint edge.
3. REMOVAL AND DISPOSAL OF BURIED MAN-MADE OBJECTS: If a buried man-made object encountered in excavation is to be removed, and its removal and disposal is not included in another item of work, such removal and disposal will be paid for at the Contract item price for the type of excavation in which such object is encountered. However, if the presence of the object is not indicated on the Plans, or in the Special Provisions, and its presence could not have been ascertained by visual inspection, the removal and disposal of such object will be paid for as extra work, as provided in Section 4-3.4, "Extra Work, instead of at the applicable Contract item price, if the Contractor so requests in writing. Such request shall be made prior to removal.

### **300-1.4 WATER WELL ABANDONMENT AND DESTRUCTION**

All water wells to be abandoned shall be destroyed in accordance with Bulletin 74-81, "Water Well Standards: State of California," of the State Department of Water Resources, and in accordance with the requirements of any permit required therefore. The work shall be performed by a water well drilling contractor licensed to perform such work. The proposed methods and procedures shall be approved by the City Engineer prior to commencement of work.

## **300-2 ROADWAY EXCAVATION**

### **300-2.1 GENERAL**

Roadway excavation shall consist of all excavation involved in the grading and construction of the roadway except structure excavation, trench excavation, and any other excavation separately designated.

### **300-2.2 UNSUITABLE MATERIAL**

Material that is unsuitable for the planned use shall be excavated and disposed of as directed by the City Engineer.

Unsuitable material is defined as material the City Engineer determines to be:

1. Of such unstable nature as to be incapable of being compacted to specified density using ordinary methods at optimum moisture content; or
2. Too wet to be properly compacted and circumstances prevent suitable in-place drying prior to incorporation into the work; or

3. Otherwise unsuitable for the planned use.

The presence of excessive moisture in a material is not, by itself, sufficient cause for determining that the material is unsuitable.

When unsuitable material is removed and disposed of, the resulting space shall be filled with material suitable for the planned use. Such suitable material shall be placed and compacted in layers as hereinafter specified for earth fill construction.

### **300-2.3 SLOPES**

Excavation slopes shall be finished in conformance with the lines and grades shown on the plans. All debris and loose material shall be removed. When completed, the average plane of the slopes shall conform to the slopes indicated on the plans. No point on the completed slopes shall vary from the designated plane by more than six inches, measured at right angles to the slope. In no case shall any portion of the slope encroach on the roadbed.

Embankment slopes shall be finished in conformance with the lines and grades shown on the plans. When completed, the average plane of the slopes shall conform to the slopes indicated on the plans. No point on the completed slopes shall vary from the designated plane by more than six inches, measured at right angles to the slope.

## **300-3 EARTH FILL CONSTRUCTION**

### **300-3.1 GENERAL**

Earth fill construction shall consist of constructing embankments, including the preparation of the areas upon which they are to be placed, buttress fills, dikes, the placing and compacting of approved material within areas where unsuitable material has been removed, and the placing and compacting of material in holes, pits and other depressions.

The native ground shall be cleared and scarified to a minimum depth of six inches, prior to placing any fill material. This scarified ground shall then be thoroughly wetted to optimum moisture content, mixed and compacted to the required density. When fills are to be placed over existing surface improvements which are to remain in place, such clearing and scarifying will not be required. Whenever a fill is constructed upon an existing structure or pavement, the pavement shall be broken by stomping in a grid pattern of five feet each way.

Rocks, broken concrete, or other solid materials, which are larger than four inches in greatest dimension, shall not be placed in fill areas.

All materials used for backfill must be free from roots, rubbish, decayed vegetable or other organic matter.



### **300-3.2      **COMPACTION REQUIREMENTS****

All embankment and fill material shall be placed in successive horizontal layers of not more than eight inches in depth of loose material. Each layer shall be spread uniformly, wetted to optimum moisture content, and compacted to the required density. The Contractor shall use equipment, which in the opinion of the City Engineer, is capable of producing the required compaction.

The upper twenty four inches of all areas under street pavement, shall be compacted so as to achieve a relative compaction of not less than 95 percent.

All embankment and fill material, in the absence of any other requirements, shall be compacted so as to achieve a relative compaction of not less than 90 percent.

### **300-3.3      **COMPACTION TESTING****

Determination of relative compaction shall be performed in accordance with the provisions of ASTM D1557. The field density of soil shall be determined by any method which will accurately and consistently indicate the density and moisture content of the soil.

The words “relative compaction” or “relative density” shall mean the ratio of the field dry density to the laboratory dry density, expressed as a percentage.

## **300-4           **STRUCTURE EXCAVATION AND BACKFILL****

### **300-4.1       **GENERAL****

Structure excavation shall consist of the removal of material for the construction of foundations for bridges, retaining walls, head walls for culverts, or other structures. It shall also include other excavation designated on the Plans, in these Specifications, or in the Special Provisions, as structure excavation.

Structure backfill shall consist of furnishing material meeting these Specifications and placing and compacting it around structures. It shall be placed to the lines designated on the Plans, or in the Specifications, or as directed by the City Engineer.

Structure excavation and structure backfill shall include the furnishing of all materials and equipment, the construction and installation of all cofferdams and other facilities, which may be necessary to perform the excavations and place and compact the backfill, and the subsequent removal of such facilities, except where they are required or permitted by the Plans or Specifications to remain in place.

### **300-4.2       **FOUNDATION MATERIAL TREATMENT****

When footing concrete or masonry is to rest on an excavated surface other than rock, care shall be taken not to disturb the bottom of the excavation. Final removal of the foundation material to grade shall not be made until just before the concrete or masonry is placed. Except when overexcavation is directed by the City Engineer, excavation below grade shall be replaced at the Contractor’s expense. It shall be placed at the same time and with the same class of concrete specified for the structure.

**300-4.3 INSPECTION**

The City Engineer will inspect and approve all excavations prior to starting the next phase of work. The Contractor shall give notice to the City Engineer upon completion of the excavation.

**300-4.4 STRUCTURE BACKFILL**

Material used for structure backfill shall conform to the provisions of Section 200-5, "Select Material." Structure backfill shall not be placed until the structure footings or other portions of the structure or facility have been inspected by the City Engineer and approved for backfill placement. No backfill material shall be deposited against the back of concrete abutments, concrete retaining walls, or the outside walls of cast-in-place concrete culverts until the concrete has developed a compressive strength of not less than 3,000 psi.

Suitable tests shall be performed prior to placing structure backfill to verify compressive strength of the concrete, as required by the City Engineer.

Structure backfill shall be placed in horizontal, uniform layers not exceeding eight inches in thickness before compaction. It shall be brought up uniformly on all sides of the structure or facility. Each layer of backfill shall be compacted to a relative compaction of not less than 95 percent.

Consolidation of structure backfill by ponding and jetting shall not be permitted. Material for use as structure backfill shall be placed and compacted in layers not exceeding one foot in thickness. The work shall be performed without damage to the structure or softening of the embankment and in such a manner that excess water will not be impounded. Vibratory or other compaction equipment shall be used when necessary to obtain the required compaction.

**300-4.5 MATERIAL SUBSTITUTIONS**

A slurry cement backfill may be substituted for structure backfill, when requested by the Contractor in writing, and approved by the City Engineer.

Material used for slurry cement backfill shall conform to the provisions of Section 200-8, "Slurry Cement Backfill."



## **SECTION 301 SUBGRADE PREPARATION AND PLACEMENT OF BASE MATERIALS**

### **301-1 SUBGRADE PREPARATION**

This Section shall govern the preparation of natural, filled, or excavated roadbed material prior to the placement of subbase or base material. All independent material testing and inspection called for by the City shall be furnished and paid for by the developer or contractor.

#### **301-1.1 CONSTRUCTION TIMING**

The roadbed subgrade may be completely tested and checked prior to placement of the contiguous concrete structures, such as curb, gutter, and sidewalk. The Contractor may also place as much of the Road Base material as is essential for completion of the contiguous structure. The Road Base material will not be tested for final acceptance prior to placement of the contiguous structures.

#### **301-1.2 CONSTRUCTION STAKING FOR SUBGRADE INSPECTION**

All Construction Stakes for the use of the Contractor and the City Engineer shall set by or under the direction of a duly licensed Engineer or Surveyor. Construction stakes shall be provided for the use of the Inspector in verifying subgrade construction.

Stakes to be used for subgrade inspection and construction shall be set at intervals not to exceed 50 feet, and at all changes in grade, beginning of curves, end of curves, all property corners, and at such additional locations as deemed necessary by the City Engineer. A cut/fill and offset distance shall be indicated on each stake for the plan elevation of the back edge of walk, lip of gutter, 1/4 point when the pavement is wider than 31 feet, and the centerline of the street.

The Engineer or Surveyor setting the stakes shall furnish three copies of a written record (cut sheets) of the staking to the City Engineer. These cut sheets shall indicate the plan station of the stake, stake elevation, plan elevation(s) for which there is a cut/fill and offset and all cut/fill and offset distances marked on each stake.

#### **301-1.3 SUBGRADE PREPARATION**

When the roadbed has been constructed to the required grade and cross-section and is in a smooth and even condition, it will be ready for preparation of subgrade.

The roadbed shall be scarified to a depth of at least six inches. The loosened material shall then be worked to a finely divided condition. The moisture content shall be brought to optimum by the addition of water, by the addition and blending of dry suitable material or by the drying of existing material. The material shall then be compacted by approved equipment to the specified relative compaction.

**301-1.4      COMPACTION**

The existing native earth, after removal of trash, vegetation, roots, and other unstable material shall be excavated to rough subgrade. The top six inches of subgrade material shall be ripped, scarified, and re-compacted to a relative compaction of 95 percent. The test method, location and number of tests shall be determined by the City Engineer. In addition to the compaction test, the grade shall be rolled with a three axle water truck carrying 3,000 gallons of water.

No appreciable indentation shall be made by the tires and no “pumping” shall occur in the subgrade. Any spots in the subgrade which show appreciable settlement or “pumping” shall be removed, dried out, re-compacted and retested until satisfactory. If the existing material cannot be made to pass the above described inspection, it shall be removed and suitable material placed, compacted, and tested. Laboratory fees for retesting shall be paid by the Contractor.

**301-1.5      TOLERANCES**

The finished subgrade shall not vary more than 0.04 feet from the specified grade and cross-section. Variations within the above specified tolerances shall be compensating so that the average grade and cross-section are equal to that which is specified. Defective areas shall be corrected, including removal and replacement of material at the Contractor’s expense. Any additional re-testing required will be at the Contractor’s expense.

**301-1.6      INSPECTION**

The City Engineer will inspect and test all compacted subgrade and must approve it prior to placing aggregate subbase or aggregate base. Any aggregate base or subbase placed prior to approval of subgrade shall be removed at the expense of the Contractor, and the affected section compacted, tested and approved by the City Engineer.

The City Engineer shall have the discretion to require the Contractor to have an Engineer or Surveyor provide written evidence of the as-built subgrade elevations. Any as-built grade information shall be provided at the sole expense of the Contractor.

**301-2           AGGREGATE SUBBASE AND AGGREGATE BASE****301-2.1       SPREADING**

Imported aggregate bases shall be delivered to the roadbed as uniform mixtures and each layer shall be spread in one operation. Segregation shall be avoided and the base shall be free from pockets of coarse or fine material.

Aggregate bases shall be deposited on the roadbed at a uniform quantity per linear foot, which quantity will provide the required compacted thickness within the tolerances specified herein without resorting to spotting, picking up or otherwise shifting the aggregate base material. At the time aggregate base is spread, it shall have a moisture content sufficient to obtain the required compaction. Such moisture shall be uniformly distributed throughout the material.



Where the required thickness is 0.50 foot or less, the base material may be spread and compacted in one layer. Where the required thickness is more than 0.50 foot, the base material shall be spread and compacted in two or more layers of approximately equal thickness. The maximum compacted thickness of any one layer shall not exceed 0.50 foot. Each layer shall be spread and compacted in a similar manner.

### **301-2.2      COMPACTION AND TOLERANCES**

The relative compaction of each layer of base material shall not be less than 95 %.

The surface of the completed aggregate base shall not vary more than 0.04 foot from the specified grade and cross-section. Variations within the above specified tolerances shall be compensating so that the average grade and cross-section are equal to that which is specified. Final checking and testing of the Aggregate Base or Aggregate Subbase for acceptance will not be performed until the adjacent curb and gutter has been satisfactorily completed.

Aggregate bases that do not conform to the above requirements shall be reshaped or reworked, watered and re-compacted to conform to the specified requirements.

### **301-2.3      PROTECTION OF AGGREGATE BASE**

Untreated base once inspected and approved must be protected from raveling and segregation by traffic. Areas once approved, but which are torn up by traffic must be re-compacted and retested prior to surfacing.

The Contractor shall be responsible for protecting the Aggregate Base or Subbase from the detrimental effects of adverse weather conditions, such as rain. Prior to commencement of work, after a work shut down due to weather, the City Engineer will verify whether or not previously completed work is still acceptable. Any work deemed to be no longer acceptable shall be reworked to the satisfaction of the City Engineer.

The Contractor may apply a penetration treatment at his own expense, to protect the untreated base, when approved by the City Engineer.



## **SECTION 302 ROADWAY SURFACING**

### **302-1 ASPHALT CONCRETE PAVEMENT**

#### **302-1.1 GENERAL**

Asphaltic concrete pavement shall consist of one or more courses of a mixture of paving asphalt and graded aggregate as specified, placed upon a prepared roadbed or base, or over existing pavement. The courses shall be of the mixture type and the dimensions shown on the plans or project specifications.

#### **302-1.2 DISTRIBUTION AND SPREADING**

At the time of delivery to the site of work, the temperature of the mixture shall not be lower than 260°F nor higher than 320°F, the lower limit to be approached in warm weather and the higher limit in cold weather. The temperature of the asphalt concrete shall be not less than 250°F immediately following placement by the paving machine. All initial breakdown rolling shall be accomplished before the temperature drops below 200°F.

Asphaltic concrete shall not be placed when the atmospheric temperature is below 50°F. Asphalt concrete shall not be placed when the underlying layer or surface is frozen, or when, in the opinion of the City Engineer, weather conditions will prevent the proper handling, finishing, or compaction of mixtures.

The asphalt concrete shall be evenly spread upon the subgrade or base to such a depth that, after rolling, it will be of the specified cross-section and grade of the course being constructed.

The thickness of the asphalt concrete shown on the plans, or as specified shall be considered the minimum thickness to be applied at any point.

The depositing, distributing, and spreading of the asphalt concrete shall be accomplished in a single, continuous operation by means of a self-propelled mechanical spreading and finishing machine designed especially for that purpose. It shall be equipped with a vibrating or tamper bar screed capable of being accurately regulated and adjusted to distribute a layer of the material to a definite pre-determined thickness. The machine shall be in good mechanical working condition.

In those instances when the City Engineer determines that a paving machine would be impracticable, asphalt concrete may be spread by tractor, blade, spreader box or hand. The method shall be approved by the City Engineer.

Where asphalt concrete is placed as an overlay on existing surfaces, the edges of the applied surface adjacent to existing concrete gutters must be raked back toward the center of the street in such a way as to provide a taper approximately 18 inches wide, satisfactory to the City Engineer.

Unless otherwise noted on the plans or in the Special Provisions, the maximum course placed shall be three inches compacted.

### **302-1.3 JOINTS**

Joints between successive runs shall be vertical and at right angles to the line of the improvement. Care shall be exercised in connection with the construction of all joints to insure that the surface of the pavement is true to grade and cross-section.

When the asphalt concrete is placed in more than one lift, the edge joints shall be offset a minimum of six inches in each successive course.

### **302-1.4 TACK COAT**

A tack coat shall be applied to any surface that is to be paved with asphalt concrete (except unprimed aggregate base or compacted native earth subgrade) including all vertical surfaces of existing pavement, curbs, gutters, and construction joints in the surfacing against which additional material is to be placed, and to other surfaces designated by the City Engineer.

Where asphalt concrete is to be placed as an overlay blanket on top of existing asphaltic surfaces, the Contractor shall prepare the surface as herein specified. The Contractor shall remove weeds and undesirable matter in cracks in the existing pavement. The street shall be swept thoroughly to remove all dirt and debris. The Contractor must notify the City Engineer at least three working days prior to beginning work in order to coordinate removal of trash and clippings.

Asphalt concrete shall be placed after the asphaltic emulsion (tack coat) has cured. If the tack coat has been damaged, additional tack coat shall be applied to those areas in advance of placing asphalt concrete or asphalt concrete base, as directed by the City Engineer. Tack coat shall conform to the provisions of Section 202-2, "Emulsified Asphalt," and shall be applied at a rate of 0.07 to 0.10 gallon per square yard.

### **302-1.5 PLACING ASPHALT**

The surface course (final lift) of asphalt concrete shall not be placed on any roadbed until all utility construction beneath the roadbed has been completed, tested, and chlorinated for sanitation, as applicable, and final utility connections have been made.

Each layer (lift) of asphalt concrete shall be a minimum of 0.12-foot compacted thickness and a maximum up to 0.24-foot compacted thickness. Sections 0.25-foot or thicker shall be placed in equal lifts.

Finished asphalt concrete surface shall be 1/8-inch (0.01-foot) above finished Portland Cement Concrete surfaces at points of contact (e.g. lip of gutter, manhole and valve box encasements, and monument box encasements). The exception to this is curb ramps which shall conform to Standard Plan 301-3.

#### **302-1.5.1 ROLLING**

Asphalt concrete shall be thoroughly compacted by rolling. The number of rollers used with each paving operation shall not be less than specified below.



| ROLLERS REQUIRED     |                                    |                                      |
|----------------------|------------------------------------|--------------------------------------|
| Tons Placed Per Hour | Compacted Thickness 1-1/2" or less | Compacted Thickness More Than 1-1/2" |
| Less Than 100        | 1                                  | 1                                    |
| 100 to 200           | 2                                  | 2                                    |
| 201 to 300           | 3                                  | 2                                    |
| More Than 300        | 4                                  | 3                                    |

Self-propelled compacting rollers shall meet the following criteria:

1. Three-axle tandems, two-axle tandems and three-wheeled rollers used for breakdown rolling shall be of such weight that the compression load on the drive is at least 325 pounds per inch wheel width.
2. Vibratory rollers used for breakdown or intermediate rolling shall have a compactive effort of not less than a dynamic force of 21,000 pounds.
3. Two-axle tandem rollers used for intermediate and finish rolling shall weigh not less than eight tons.
4. Pneumatic-tired rollers used for intermediate rolling shall be the oscillating type having a width of not less than four feet and equipped with pneumatic tires of equal size and diameter, having treads satisfactory to the City Engineer. Wobble-wheel rollers will not be permitted. The tires shall be so spaced that the gap between adjacent tires will be covered by the tread of the following tire. The tires shall be inflated to 90 pounds per square inch.
5. A two-axle tandem roller, weighing at least five tons may be used when the areas to be paved are not to be subjected to vehicular traffic and when the asphalt is placed in these areas at a rate less than 100 tons per hour.
6. Other rollers may be used subject to prior approval by the City Engineer.

As soon as the layer of asphalt concrete has been placed, it shall be thoroughly compacted by rolling. Rolling shall be commenced along the lower edge of the area to be rolled and continued until the edge is thoroughly compacted, after which the roller shall be gradually advanced to the crown point, both sides being rolled in like manner. Rolling shall be continued until the pavement layer has become thoroughly compacted throughout and is true to grade and cross-section.

All rollers must be maintained in good mechanical condition, and those that cannot be driven along a straight path or operated without jerking, shall not be used. No leakage of petroleum products from any roller shall be allowed to come in contact with pavement being constructed, nor shall any roller be permitted to stand motionless on any portion of the work. The surfaces of all roller wheels shall be treated with sufficient water to prevent the pickup of bituminous materials, but under no circumstances shall the quantity of water used be detrimental to the surface of the pavement being rolled.



**302-1.5.2 ADJUSTMENTS**

Manholes, valve boxes, monument, boxes, etc. shall be brought to grade in accordance with City of Davis Standard Plans after final pavement lift has been placed. All adjustments of iron shall be made using new iron, boxes, etc., unless approved by the City Engineer. All manhole frames, lids or gates, valve boxes, monument boxes, and any other style of box or lid shall be reused where possible. Where required, new equipment shall be supplied by the Contractor at no expense to the City.

**302-1.5.3 ACCEPTANCE SAMPLING AND TESTING OF ASPHALTIC CONCRETE**

Prior to the use of materials, the Contractor shall submit to the City Engineer values from the tests required in Section 39 of the State Specifications.

Values from such tests shall meet the requirements in Section 39-2.02 of the State Specifications.

The City Engineer shall approve core locations for sampling to accomplish post-installation tests. Cores shall be a minimum of four inches (4") in diameter. The City reserves the right to require additional cores in the event that insufficient data was obtained from the original cores. At the direction of the City Engineer, the Contractor shall core and verify the asphalt concrete section.

During construction, sufficient testing shall be arranged to ensure that the following requirements are attained. Certified copies of all results shall be delivered to the City Engineer within 48 hours or work shall be suspended.

- Asphalt Content (California Test 310) or similar method as approved by the City Engineer

**302-1.5.4 DENSITY AND SMOOTHNESS**

Upon completion, the pavement shall be true to grade and cross-section. When a ten foot long straightedge is laid on the furnished surface parallel to the centerline of the roadway, the surface shall not vary from the edge of the straightedge more than one-eighth inch, except at intersections or a change of grade. Any areas that are not within this tolerance shall be brought to grade immediately following the initial rolling.

The completed surfacing shall be thoroughly compacted, smooth, and free from ruts, humps, depressions, or irregularities. Any ridges, indentations or other objectionable marks left in the surface of the asphalt concrete by blading or other equipment shall be eliminated by rolling or other means. The use of any equipment that leaves ridges, indentations, or other objectionable marks in the asphalt concrete shall be discontinued, and acceptable equipment shall be furnished by the Contractor.

The compaction after rolling shall be 95 percent of the density obtained with the California Kneading Compactor per California Test Method #304. The field density of compacted asphalt concrete shall be determined by:

1. A properly calibrated nuclear asphalt testing device in the field, or

2. ASTM D1188 when slabs or cores are taken for laboratory testing. Zinc stearate may be substituted for paraffin.

In case of dispute, method (b), California Test #304, shall be used.

### **302-1.7 FOG SEAL**

All paving, except bikepaths, shall receive a fog seal on the top course as soon after paving as is practical. It shall be the Contractor's responsibility to protect new paving from dirt and other objectionable material prior to fog sealing. If the pavement does become dirty prior to sealing, the Contractor shall clean it to the satisfaction of the City Engineer, prior to sealing. The Contractor shall take care to protect gutters, curbs, sidewalks, etc. during the fog sealing operation.

Fog seal shall conform to the provisions of Section 202-2, "Emulsified Asphalt," and shall be applied at a rate of 0.07 to 0.10 gallon per square yard.

### **302-1.8 BIKEPATH SEAL COAT**

All bikepath paving shall receive a seal coat on the top course as soon after paving as is practical. The seal coat material shall be as specified in Section 202-2, "Emulsified Asphalt." Fog seal will not be allowed. Seal coat shall be applied in two coatings. The second coat shall not be applied until the first coat has cured sufficiently in accordance with manufacturer's recommendations.

#### **302-1.8.1 WEATHER AND TEMPERATURE**

The seal coat shall be applied only when the air temperature is at least 50°F and rising. Seal coat shall not be applied during or immediately after rainfall.

#### **302-1.8.2 SURFACE CLEANING**

Prior to application, the pavement surface shall be thoroughly cleaned of all dirt, sand, and other foreign material using appropriate methods. All weeds and other vegetation shall be removed. All cracks shall be thoroughly cleaned of any foreign matter. Cracks wider than one-eighth inch shall be filled with a suitable crack filler.

#### **302-1.8.3 MIXING**

The sealer shall be mixed to a uniform free-flowing consistency. Water may be added, not to exceed 20 percent by volume, to obtain a semi-fluid consistency.

#### **302-1.8.4 APPLICATION PROCEDURE**

In exceptionally hot weather, the surface shall be dampened with water, prior to application of the first coat of sealer. All excess water shall be removed so as to leave the surface only slightly damp.



The sealer shall be applied in continuous parallel lines. It shall be spread using rubber faced squeegees and/or mechanized spreading equipment. The second coat may be applied as soon as the first coat is dry to touch and will not scuff under normal walking. The finish surface shall be fully cured prior to opening the bikepath to traffic.

### **302-1.8.5 RATE OF APPLICATION**

The minimum rate of application shall be 30 gallons per 1,000 square feet (0.27 gallons per square yard), applied in two coats. The finish surface shall be smooth, uniform and free of ridges, bumps or coarse texture. The Contractor shall supply scale tags to the City showing material and quantity of gallons used on the project.

## **302-2 SLURRY SEAL**

### **302-2.1 GENERAL**

Immediately prior to applying slurry seal, the street surface shall be cleaned of all loose material, silt, vegetation, and other objectionable material.

The Contractor shall protect existing concrete curb and gutters, maintenance hole covers, monuments, valves and cleanout covers and keep them clean and free of slurry seal mixture. They shall be protected by placing a covering of Kraft paper or equivalent prior to the slurry application. A film of solvent or diesel fuel is not acceptable. The Contractor shall be responsible for cleaning or replacing such utilities if they are not adequately protected from the slurry seal.

The Contractor shall make all arrangements for the temporary storage of materials. A written release shall be obtained from the property owner providing the facilities for such temporary storage. The release shall absolve and release the City of all responsibility resulting from the use of said storage site. A written copy of this release shall be delivered to the City Engineer.

### **302-2.2 MIXING EQUIPMENT**

The slurry seal shall be mixed and spread by a machine specifically designed and manufactured for this purpose. The machine shall be maintained in a good mechanical working condition for the duration of the Contract.

The Contractor shall provide evidence of calibration of all measuring devices, when requested by the City Engineer.

The machine shall be equipped to deliver accurate volumetric proportions of emulsion, water, and aggregate to the mixer. The machine shall be equipped with a pugmill mixer, capable of thoroughly blending all ingredients. The emulsion shall be delivered into the mixer by means of a positive displacement pump. The aggregate feeding device shall be connected directly to the drive for the emulsion pump. The machine shall pre-wet the aggregate immediately prior to mixing it with emulsion.



The mixing machine shall be equipped with a water pressure system and fog-type spray bar, adequate for complete fogging of the surface preceding spreading equipment. The minimum application rate shall be 0.05 gallon per square yard.

### **302-2.3 SPREADING EQUIPMENT**

The slurry mixture shall be uniformly spread by means of a controlled spreader box capable of spreading a traffic lane width. The spreader box shall have strips of flexible rubber belting or similar material on each side and in contact with the pavement to prevent loss of slurry from the box. The box shall have baffles, or other suitable means, to ensure uniform application on super-elevated sections and shoulder slopes.

The spreader box shall have a rear flexible strike-off blade which shall make close contact with the pavement. It shall be adjustable to match the various crown shapes so as to apply a uniform coating of slurry seal.

In areas inaccessible to the controlled spreader box, slurry mixture may be spread by other approved methods.

### **302-2.4 PROPORIONING**

Asphaltic emulsion, as defined in Section 202-2, shall be added at a rate of 15 to 25 percent, by weight, of dry aggregate. If necessary for workability, a retarding agent may be used, provided that it does not affect the slurry seal. The quantities of water and retarder added, if any, shall be adjusted to insure proper workability. The amounts shall be adjusted such that bleeding, raveling, separating, or other distress will not occur when uncontrolled traffic is permitted on the slurry seal. Uncontrolled traffic will be permitted to return to the sealed street three hours after placement.

### **302-2.5 PLACEMENT**

The slurry seal shall not be placed when, in the opinion of the City Engineer, weather conditions will prevent the proper completion of the work. The slurry seal shall not be placed when the atmospheric temperature is below 65°F.

The slurry shall be applied at a rate of 8 to 12 pounds of dry aggregate per square yard. Before placing the slurry seal, the pavement surface shall be cleaned by sweeping, flushing or other means necessary to remove all loose particles of paving, all dirt and all other extraneous material.

Hand tools shall be available in order to remove spillage. Ridges or bumps in the finished surface will not be permitted.

The mixture shall be uniform and homogeneous after spreading on the road and shall not show separation of the emulsion and aggregate after setting.

Adequate means shall be provided to protect the slurry seal from damage by traffic until such time that the mixture has cured sufficiently.

## **SECTION 303 PORTLAND CEMENT CONCRETE CONSTRUCTION**

### **303-1 CONCRETE CURB, GUTTER, SIDEWALK AND DRIVEWAY CONSTRUCTION**

#### **303-1.1 GENERAL**

The construction of curb, gutter, sidewalks, and driveways shall conform to the applicable Standard Plans. Unless otherwise specified, all curb, gutter, and sidewalk shall be placed monolithically.

Concrete shall conform to Section 201, "Concrete and Related Materials," and shall be Class A (six sack mix, 3,000 psi minimum). Concrete for all sidewalk and adjacent curb and gutter, whether or not placed monolithically, shall contain polypropylene fibers at a rate of 1.5 pounds per cubic yard of concrete.

#### **303-1.2 MIXING AND DELIVERY OF CONCRETE**

Mixing of concrete shall conform to the provisions of Section 90-6, "Mixing and Transporting," of the State Specifications, except as modified herein.

Concrete shall be delivered to the jobsite in transit mix trucks for batches equal to or exceeding one cubic yard in size. Concrete shall be delivered in transit mix trucks or may be mixed in portable mechanical mixers for quantities between one cubic yard and 1/3 cubic yard. Concrete shall be mixed by one of the above methods or shall be mixed onsite in accordance with Section 90-6.05, "Hand Mixing," of the State Specifications, for batches less than 1/3 cubic yard. The City reserves the right to require concrete cylinders for all methods of mixing concrete.

The concrete shall be mixed continuously after batching and shall be thoroughly mixed prior to placement. Adequate provision shall be made to minimize delays in the delivery and placement of the concrete. A delay of over 90 minutes between batching and placing concrete in the forms shall be considered as reasonable cause for rejection of the work. Concrete so rejected shall be removed from the forms, disposed of and replaced with new concrete, all at the Contractor's expense.

Each batch of transit-mixed concrete delivered to the job site shall be accompanied by a Weighmaster's Certificate showing the volume of concrete, the weight of each ingredient, in pounds, and the date and time of batching. A copy of each Certificate shall be presented to the City Engineer.

The amount of water to be added and the regulation of water control equipment shall be subject to the approval of the City Engineer.

#### **303-1.3 ADMIXTURES**

The use of admixtures, except as specified herein, shall require approval of the City Engineer prior to their use. The Contractor shall submit a written request for the City Engineer's consideration. The request shall contain information about the proposed mix design and reasons for the use of the



admixture. All admixtures shall conform to the provisions of Section 90-4, "Admixtures," of the State Specifications.

The Contractor may use an air-entraining admixture to facilitate the use of any construction procedure or equipment. Air-entraining Admixtures shall conform to the requirements of ASTM Designation C260. The entrained air content, when tested in accordance with California Test Method 504, shall not be less than three percent nor more than five and one-half percent.

### **303-1.4 POLYPROPYLENE FIBERS IN CONCRETE**

All curb, gutter, and sidewalk and extruded median curb construction shall use concrete containing polypropylene fibers. The ticket for each load shall state the quantity of fibers added to the load.

### **303-1.5 SUBGRADE PREPARATION**

Subgrade shall be prepared in accordance with Section 301, "Subgrade Preparation and Placement of Base Materials." Upon completion and approval of the subgrade and after the forms have been placed, a two inch thick layer of 3/4" aggregate base (A.B.) shall be placed. The A.B. shall be wetted and compacted to the satisfaction of the City Engineer.

### **303-1.6 FORMS**

Lumber used for forms shall have a true, smooth upper edge, shall be surfaced on the side to which concrete will be placed, and shall not be warped. Form lumber shall be not less than one and one-half inches in surfaced thickness. Benders or thin planks, half-inch minimum thickness, may be used on curves, grade changes, or at curb returns, if rigidly placed.

All forms shall be clean and shall be lightly coated with a form release oil which will prevent concrete from adhering to the forms.

All forms shall be carefully set to proper alignment and grade. Forms shall not vary from horizontal alignment by more than 0.05 feet nor from vertical grade by more than 0.02 feet.

Forms shall be held rigidly in place by the use of steel or wooden stakes set a maximum of five feet apart. Clamps, spreaders and braces shall be used as required to ensure rigidity. A dirt windrow shall be placed against the forms to stabilize them from bulging. Forms shall have smooth, even lines in both the horizontal and vertical planes.

Forms on the face of vertical curbs shall remain in place for over two hours, but less than six hours after the concrete has been placed. All other forms shall remain in place for at least 12 hours after concrete placement.

### **303-1.7 SLIP FORM EQUIPMENT**

Slip form equipment shall be provided with traveling side and top forms of suitable dimensions, shapes, and strength to support the concrete for a sufficient length of time during placement to



produce the required cross-section. The equipment shall spread, consolidate and screed the freshly placed concrete in such a manner as to provide a dense and homogeneous product.

The slip form equipment shall have automatic sensor controls which operate from an offset control line. The line and grade of the slip form equipment shall be automatically controlled.

### **303-1.8 CONSTRUCTION JOINTS**

A construction joint shall be placed at the end of curb returns and where concrete placed using slip form equipment joins with concrete placed using other methods. A construction joint shall also be used when fresh concrete joins with concrete that has been in place for 90 minutes or longer. The joint shall extend for the full depth through the curb, gutter and sidewalk at each location. The joints shall be at right angles to the face of curb.

A full depth expansion joint is an acceptable construction joint. Expansion joint material shall conform to Section 201-3, "Expansion Joint Filler."

An expansion joint shall be used when so required by the Plans or Specifications.

### **303-1.9 DEEP TOOL JOINTS**

Deep tool joints shall be placed at intervals of twelve feet in all curb, gutter and sidewalk construction. The joint shall extend for the full width of the curb, gutter and sidewalk at each location. The joints shall be constructed at right angles to the face of curb.

The joints shall be constructed a minimum depth of 25 percent of the thickness of the concrete, or minimum of one inch in depth, whichever is greater. The width of such joints shall not be less than one-eighth inch or more than one-fourth inch. Joints shall be made using an appropriate deep jointing tool or shall be made using removable strip forms.

Deep tool joints at back of curb or back of roll shall be a minimum of one and one-half inches deep.

### **303-1.10 PLACING OF CONCRETE AND FINISHING**

No concrete shall be placed or finished in the rain. It shall be the Contractor's responsibility to schedule the work accordingly.

Concrete shall be placed in such a manner as to prevent segregation of the aggregate and prevent the formation of voids or rock pockets. Freshly poured concrete shall be spaded and tamped or vibrated until thoroughly compacted. If for any reason, including the end of a day's work, work is terminated, a vertical, square-ended expansion joint shall be made. If a delay of 30 minutes or more occurs between batches, the new concrete shall be worked in to the old to ensure a uniform joint.

Particular care shall be taken to ensure that the final cross-section conforms to the Standard Plans. Prior to final finishing, all gutter slopes shall be checked by flowing a small quantity of water in the gutter. This check shall be made in the presence of the City Engineer. Any high spots or depressions

detected during this check shall be corrected during finishing so that water does not stand on the finished section.

All concrete surfaces shall be finished with steel trowels to the satisfaction of the City Engineer. Finishing shall be performed when the concrete is sufficiently plastic. After trowelling, the surface shall be given a light broom finish. All exposed edges shall be rounded and scoremarks placed as required by the City Engineer.

### **303-1.11 MARKINGS FOR SERVICES**

Water and sewer service locations shall be stamped on the top of vertical curb or the upper part of the roll on rolled curb. "S or "W" marks, as appropriate, shall be three inches high and one-fourth inch deep. Location of the marking shall be accurate within one-half foot.

### **303-1.12 CURING OF CONCRETE**

Immediately after the concrete has been finished, a curing compound shall be evenly applied to all exposed surfaces. Application shall conform to the requirements of Section 90-7.01B, "Curing Compound Method" of the State Specifications. The compound shall be applied so that it forms a uniform, water-impervious film, free from pinholes or other imperfections and shall not crack, peel, or disintegrate.

### **303-1.13 REPAIRS AND REPLACEMENT OF CONCRETE**

Existing concrete shall be sawcut to existing scoremarks or expansion joints prior to removal. Minimum depth of sawcuts shall be one and one-half inches or 25 percent, of the concrete thickness, whichever is greater. The edges remaining after removal shall be square, uniform, and with no chips or spalling. Replaced portions of concrete shall be finished to match existing surfaces.

Minor depressions or high spots may be repaired by application of epoxy or grinding, respectively, if prior approval is given by the City Engineer.

### **303-1.14 EXTRUDED BARRIER CURB**

Extruded concrete curb shall be anchored to existing pavement by an adhesive. The existing surface of the pavement shall be thoroughly cleaned prior to the application of the adhesive. The pavement shall be cleaned either by wire brushing or by blast cleaning, and as directed by the City Engineer. The cleaned surface shall be free from dust, moisture, loose material, and oil.

## **303-2 CONCRETE STRUCTURES**

Concrete structures shall conform to the provisions of Section 51, "Concrete Structures," and Section 90, "Portland Cement Concrete," of the State Specifications.



## **SECTION 304 UNDERGROUND PIPELINE CONSTRUCTION**

### **304-1 DEFINITIONS**

#### **304-1.1 TRENCH DEFINITION**

For the purposes of these Specifications, a trench is defined as an excavation in which the total depth is greater than the width of the bottom of the excavation. All other types of excavation and earthwork operations shall comply with the provisions of Section 300, "Removals, Excavation and Earthwork."

#### **304-1.2 APPURTENANT EXCAVATION**

Excavations for appurtenant structures including, but not limited to, maintenance holes, pipelines, transition structures, junction structures, vaults, valve boxes, catch basins, thrust blocks and boring pits shall, for the purposes of these Specifications, be deemed to be in the category of trench excavation.

#### **304-1.3 ADDITIONAL DEFINITIONS**

For the purposes of these Specifications, the following definitions shall apply:

**BACKFILL** means either initial backfill or final backfill

**BEDDING** means all material supporting the pipe from the bottom of the excavation to the bottom of the pipe or conduit. Bedding shall be a minimum of four (4) inches in depth for all pipe materials.

**FINAL BACKFILL** means all material placed between the initial backfill and to the bottom of the subgrade in paved or gravel surfaced areas or to the top of the finished grade in unsurfaced areas.

**IMPROVEMENT AREA** means any area within the City's right-of-way.

**INITIAL BACKFILL** means all material placed above the bedding to 12 inches above the top of the pipe.

**SPECIAL IMPROVEMENT AREA** means any area identified as a Special Improvement Area on the Plans or in the Special Provisions for which all requirements for an Improvement Area shall apply.

### **304-2 GENERAL REQUIREMENTS**

Excavation for all underground pipelines and conduits shall be by open trench, unless otherwise specified or shown on the plans. Excavation by any other method requires the prior approval of the City Engineer.

Trenching shall be accomplished by approved trenching machinery, capable of maintaining the designed grade. Methods used in excavation shall not cause damage to surrounding property or



damage pavement and other existing improvements that are to remain. Outriggers for excavation and other heavy equipment shall be fitted with street pads to prevent pavement damage.

All trenches shall be excavated vertically wherever possible, but in no case shall the walls deviate from vertical between the bottom of the trench and approximately one foot above the top of the pipe. Additional requirements for trenching are shown on the various City Standard Plans included in Part 4 of these Specifications or may be included in the project Plans or Special Provisions.

Attention is directed to the provisions of Section 7-9, "Preservation of Property." Permission to use any particular method of excavating and backfilling, including specific equipment shall not be construed as guaranteeing or implying that the use of such equipment will be appropriate for the situation. The Contractor shall conduct backfill and compaction operations such that existing improvements are saved from damage, and such that the adjacent ground does not shift or settle so as to cause damage to existing improvements, whether or not said improvements are a part of the work.

### **304-3 SAFETY**

#### **304-3.1 GENERAL**

Attention is directed to the provisions of Section 5-2.1, "Trench Excavation Safety Plans," and Section 7-1.10, "Trench Safety."

Prior to the excavation of a trench five feet in depth or greater, and into which a person will be required to descend, the Contractor shall first obtain a permit from the State Division of Industrial Safety. Upon request, the Contractor shall provide the City Engineer with a copy of the permit. In the event that the permit expires, is revoked, or is otherwise invalidated, the Contractor shall notify the City Engineer immediately, in writing.

#### **304-3.2 SHORING AND BRACING**

The minimum requirement for the manner of shoring and bracing excavations shall be as set forth in the Rules, Orders, and Regulations of the Division of Industrial Safety of the State of California.

Contractors may be required, at the discretion of the City Engineer, to provide drawings or calculations by a registered engineer five (5) working days prior to beginning construction for specially designed bracing and shoring of an excavation where standard pre-manufactured bracing or shoring cannot be used.

Contractors shall submit a copy of their current Annual Excavation Permit issued by the State of California Division of Industrial Safety (Cal-OSHA) with the Contractor's Trench Safety Plan prior to the start of construction.

After the pipeline has been installed and sufficiently backfilled to protect the pipe, all shoring, bracing, and sheeting shall be removed. All voids left by the removal of such bracing shall be carefully filled with material used for backfill compacted in place.

**304-3.3 ACCESS TO TRENCHES**

Safe and suitable ladders shall be provided for all trenches four feet or greater in depth. Ladders shall project three (3) feet above the top of the trench excavation and shall be secured in place. One ladder shall be provided for each 50 feet of open trench, or fraction thereof and shall be located so that workers in the trench need not move more than 25 feet to a ladder.

**304-4 HORIZONTAL AND VERTICAL ALIGNMENT**

All pipe lines shall be laid true to plan line and grade, within the tolerances specified for the various types of facility. Laser equipment shall be used to provide horizontal and vertical control. Approval for any other method of maintaining control shall be obtained from the City Engineer prior to start of construction.

The laser equipment used shall be of a type compatible for the use intended and shall be used only by properly trained workers. The laser equipment shall be in good working condition, and shall be properly adjusted and calibrated.

Control markers used for setup of the laser equipment shall consist of good sound construction stakes. Control markers shall be nominal "two-by-two" (2"x2"), six inches long, wood stakes set in firm, stable ground. The stakes shall be driven flush with the ground surface. Alternate methods of providing control markers, which are substantially the equivalent to the above, may be used depending on ground conditions.

Construction stakes shall also be provided at intervals not to exceed 50 feet on straight runs. On curved runs, both horizontal and vertical, stakes shall also be provided at intervals not to exceed 25 feet. Each stake location shall consist of a hub, driven flush with the ground surface, and a long lath, appropriately marked and flagged. A nail and shiner and painted messages shall be used on pavement surfaces. Such staking shall provide the station and offset to the sewer main as well as the cut to the nearest one-tenth foot (0.10').

**304-5 EXCAVATION**

Placement of spoil materials on the paved street shall not be allowed.

**304-5.1 MAXIMUM LENGTH OF OPEN TRENCH**

The maximum length of open trench, where prefabricated pipe or other structure are to be placed, shall be 200 feet, or the distance necessary to accommodate the amount of pipe installed in a single day, whichever is greater, unless otherwise permitted by the City Engineer. The length of open trench includes open excavation, pipe laying and appurtenant construction, and backfill which has not been temporarily resurfaced.

The maximum length of open trench for cast-in-place concrete pipe shall be that length for 2-1/2 days work (trench in which pipe was placed during the previous 24 hours plus the trench required for the next day's work plus additional trench one half the length of the trench required for the next day's work).



All trenches or excavations within a sidewalk area or driveway shall be covered with steel plates. The use of plywood for open trench or excavation cover shall not be allowed within or adjacent to City right-of-way.

The remainder of the trench shall be backfilled and compacted, and when in streets, opened to traffic as soon as possible.

Failure by the Contractor to comply with the above limitations may result in an order to halt the work until such time as compliance has been achieved.

### **304-5.2 TRENCH WIDTH**

Trenches shall be excavated to a width that will provide adequate working space and will permit the proper placement of bedding and initial backfill. The maximum width of trench shall be as shown on the Plans, as specified in the Special Provisions, or as shown on Standard Plan 201-1.

Additional width may be required to permit placement of shoring, bracing, and appurtenances in accordance with trench safety requirements. In the event that, due to adverse soil or other conditions, a vertical wall cannot be maintained to approximately one foot above the top of pipe, or if the trench width exceeds the maximum width as specified above, special bedding or backfill methods, a higher strength pipe, or any other additional work as required or approved by the City Engineer to adequately install and protect the pipe equal to the original design, shall be employed at no additional cost to the City.

### **304-5.3 OVEREXCAVATION**

Whenever, in the opinion of the City Engineer, the bottom of the trench is soft, spongy, unstable, rocky, or otherwise unsuitable as a foundation for pipe bedding, the unsuitable material shall be removed to a minimum depth of six (6) inches or to a depth designated by the City Engineer.

If material more than twelve (12) inches below the trench bottom is ordered removed by the City Engineer, the excavation below that point and the imported material required to backfill the trench to that elevation will be paid for as extra work as provided in Section 4-3.4 unless otherwise specified in the Special Provisions.

If any trench is excavated below the bottom grade as shown on the plans, it shall be refilled to grade with the bedding material appropriate to the system under construction, and compacted to a relative compaction of 90 percent. If such overexcavation is due to the neglect or error of the Contractor, all labor and material shall be at the Contractor's expense.

## **304-6 BACKFILL AND COMPACTION**

### **304-6.1 GENERAL**

Bedding for the various types of pipe and conduit shall be installed as required in these Specifications and as shown on the appropriate City Standard Plans.



The Contractor shall proceed with backfilling operations as soon as possible after pipe installation, except as otherwise required. Care shall be exercised so that the pipe will not be damaged or displaced during backfilling and compacting operations.

Backfill shall not be dropped directly upon pipe. To prevent longitudinal movement of the pipe, dumping backfill material into the trench and then spreading will not be permitted until material has been placed and compacted to a level 1-ft over the pipe.

Except for drain rock materials being placed in overexcavated wet areas, backfill shall not be placed until after all water is removed from the excavation.

Any portion of the trench that exceeds six feet in width shall be considered earth fill and shall be backfilled in conformance with the provisions of Section 300-3, "Earth Fill Construction."

### **304-6.2 BEDDING**

Bedding shall provide uniform and continuous support along the barrel of the pipe. Blocking of the pipe is not permitted.

Bell holes shall be excavated per the manufacturer's recommendations. The minimum depth of bedding material shall be placed under the bell. Care shall be taken to ensure that the bell hole is no larger than necessary to accomplish proper joint assembly.

### **304-6.3 INITIAL BACKFILL**

Extreme care shall be taken when consolidating the backfill around the pipe. For pipe 12 inches in diameter and smaller, no more than one-half of the pipe shall be covered prior to shovel slicing the haunches of the pipe. For pipe greater than 12 inches in diameter, no more than 6 inches shall be covered prior to shovel slicing. Sufficient care shall be taken to prevent movement of the pipe and damage to the polyethylene encasement during shovel slicing. Shovel slicing shall be witnessed by the City inspector.

Compaction equipment shall not make direct contact with the pipe.

Initial backfill shall be of the same material that was placed for the bedding. Initial backfill shall be compacted under the haunches of the pipe.

When groundwater is encountered or where the pipe is to be installed below historic groundwater levels, the trench shall be kept dry until the bedding material is placed and compacted, pipe placed, initial backfill is placed and final backfilling of the trench or excavated area is at least fifty percent (50%) complete. A geotextile fabric barrier shall be placed around the initial backfill and between the initial backfill and final backfill.

### **304-6.4 FINAL BACKFILL**

Final backfilling shall take place after the initial backfill has been inspected and accepted.

Trenches less than or equal to six inches in width (i.e. narrow trenches) shall be backfilled and compacted in accordance with Standard Plan 201-1, "Trench Details."

For trenching within City streets, all of the backfill material above the initial backfill to subgrade shall conform to the requirements for Class 2 Aggregate Base. The backfill shall be compacted so as to achieve a minimum relative compaction of 95 percent. Upon approval of the City Engineer, slurry cement backfill in accordance with Section 200-8 may be substituted as backfill. No backfill, equipment, or other loads may be placed atop slurry cement backfill until it has attained sufficient strength in accordance with ASTM D6024.

For trenches that are not within City streets, native material providing that the native material is free of rocks, rubbish, debris, and other unsuitable material. The backfill shall be compacted so as to achieve a minimum relative compaction of 90 percent, and the top lift shall be thoroughly wheel-rolled with equipment to the satisfaction of the City Engineer. When the required compaction cannot be achieved using native material, aggregate base material shall be required at no additional expense to the City.

Where not otherwise required, the final backfill material shall be finely divided so that no rocks or clods shall exceed two and one-half inches in greatest dimension. Native material, broken concrete or asphalt concrete obtained from excavation on the project will be permitted, subject to the maximum particle size requirement. In the event that broken concrete or A.C. is included in the backfill, it shall be adequately mixed with other material so as to eliminate voids. Organic material or other deleterious substances shall not be included in the backfill.

### **304-6.5      COMPACTION**

All backfill shall be mechanically compacted. Permission to use specific compaction equipment shall not be construed as guaranteeing or implying that the use of such equipment will achieve the required compaction results or will not result in damage to adjacent structures, existing improvements, surrounding ground or improvements being installed. The Contractor shall be completely responsible for obtaining the required compaction. The Contractor is required for notifying the City Engineer when compaction testing is to be completed.

The maximum lift thickness allowed will be determined by the method used to compact and densify the backfill, but shall never exceed 1 foot. After the placing of backfill has been started, the Contractor shall proceed with compaction as soon as practicable.

All trench backfill shall be tested for compaction after every two (2) vertical feet of backfill. Trench backfill that is not tested shall be considered as backfill that has failed compaction. All backfill that has failed compaction test shall be removed and the trench backfill recompacted.

The Contractor shall be responsible for all costs to retest any previously failed compaction tests along with any additional staff time.



**304-6.5.1 BACKFILL COMPACTION BY MECHANICAL METHODS**

Backfill shall be mechanically compacted by means of tamping rollers, sheepsfoot rollers, or other mechanical tampers. All such equipment shall be of a size and type satisfactory to the City Engineer.

Permission to use specific compaction equipment shall not be construed as guaranteeing or implying that the use of such equipment will achieve the required compaction results or will not result in damage to adjacent structures, existing improvements, surrounding ground or improvements being installed. The Contractor shall be completely responsible for obtaining the required compaction. The Contractor is required to notify the City Engineer when compaction testing is to be completed.

Impact-type pavement breakers (stompers) will not be permitted over any pipe material unless there is a minimum of five feet of cover over said pipe.

Material for mechanically compacted backfill shall be placed in horizontal lifts which, prior to compaction, shall not exceed the depths specified below for the type of equipment used:

- a) Impact, free-fall or “stomping” equipment; shall not be used as a means of compaction;
- b) Self-propelled vibratory equipment, including vibratory smooth-wheel rollers and vibratory pneumatic-tired rollers; maximum lift depth of two feet;
- c) Portable engine driven jumping-type compactors and backhoe boom-mounted vibratory type compactors; maximum lift depth of one and one-half (1½’) feet;
- d) Self-propelled rolling equipment, including vibratory and static sheepsfoot, grid, static smooth-wheel, static pneumatic-tired, and segmented wheeled; maximum depth of one foot; and
- e) Hand directed pneumatic tampers and portable vibratory plates; maximum lift depth of four inches (0.33 feet).

Each layer shall be evenly spread, moistened (or dried if necessary), and then compacted so as to attain a minimum relative compaction of 95 percent.

All trench backfill shall be tested for compaction after every two-(2) vertical feet of backfill. Trench backfill that is not tested shall be considered as backfill that has failed compaction. All backfill that has failed compaction test shall be removed and the trench backfill recompacted.

The Contractor shall be responsible for all costs to retest any previously failed compaction tests along with any additional staff time.

**304-6.5.2 BACKFILL COMPACTION BY WATER-JETTING**

Compaction by jetting or excess moisture conditioning will not be permitted except by written permission of the City Engineer.

The purpose of jetting shall be to accomplish consolidation and compaction of the backfill material by using water. All air pockets and voids shall be removed during the jetting operations. Jetting will



also include removal of excess water from the backfilled trench. Any liquid substance, chemical or other additive, other than water, shall not be added to the water or used on the backfill material during jetting operations.

Jetting will only be allowed when the backfill material is a suitable granular, free draining soil. The adjacent soils shall also be free draining such that the water rapidly drains out of the trench backfill. If the adjacent soils are not free draining (i.e., predominantly clays and silts), then the Contractor shall provide a means of rapidly removing the water from the trench. This may be accomplished by providing weep holes in the bottom of maintenance holes and using a pump to evacuate the water. The weep holes shall be filled with grout after completion of backfill operations.

Jetting shall be accomplished by the use of a steel pipe at least two inches in diameter. The pipe shall be long enough to reach to the bottom of the trench. A hose shall be attached which carries a continuous supply of water under pressure.

The Contractor shall apply water in a manner, quantity and rate sufficient to thoroughly saturate the thickness of the lift being jetted. In no case shall the lift thickness exceed five feet of loose material. The jetting pipe shall be shoved down into the trench at four foot maximum intervals along the trench. The trench shall be jetted until, after five minutes, water shall show on the surface.

When the required compaction or consolidation cannot be attained by jetting alone, the Contractor shall employ additional methods to achieve the required results.

### **304-7            TEMPORARY AND PERMANENT RESURFACING**

Initial cut in street pavement shall be equal to the width of the trench with the option of being jack hammered or saw cut. Drop hammer shall not be used to cut pavement. Final cut in street pavement shall be 12" wider than the trench width (6" each side) and shall be saw cut in neat, parallel lines.

Temporary resurfacing shall be placed and maintained wherever excavation is made through existing pavement. The temporary resurfacing shall be maintained in such a way as to provide for the safety and convenience of the public.

Temporary resurfacing shall be placed as soon as the condition of the backfill is considered by the City Engineer to be suitable to receive such resurfacing. It shall remain in place until the City Engineer determines that the condition of the backfill is suitable for permanent resurfacing.

When ordered by the City Engineer, the Contractor shall immediately proceed to place any temporary resurfacing. Upon the Contractor's failure to comply in a timely manner with such an order, the City Engineer may cause such work to be performed by other forces. Payment for such work performed by other forces will be deducted from money which may become due to the Contractor, or the City Engineer will require that payment for such costs be paid to the City prior to final acceptance of the Contract.

Final paving above the trench section shall be placed within 14 days of its backfill and compaction. Extension may be granted by the City Engineer due to weather conditions. In the event paving is not done within 14 days, the City will consider this as incomplete work and will take necessary action in accordance with the prevailing City ordinances and policies.

Temporary surfacing shall be removed before placement of final surface. Final surfacing shall be placed on undisturbed, previously inspected and compacted aggregate base or approved slurry cement backfill. Re-compaction shall be required for any disturbed base or surface. Edges of permanent patches shall be crack sealed with rubberized crack sealer (Crafco or approved equal) in accordance with manufacturer instructions prior to acceptance.

All temporary and permanent resurfacing shall conform to the applicable City of Davis Standard Plans.

## **SECTION 305 WATER SYSTEMS**

### **305-1 TRENCH EXCAVATION AND BACKFILL**

All trench excavation and backfill shall be performed in accordance with the provisions of Section 304, "Underground Pipeline Construction."

### **305-2 HANDLING OF MATERIALS**

All pipe and appurtenances shall be handled as per manufacturer's recommendations. Material identified as not meeting specifications shall be removed from the work site immediately.

All pipes, valves, fittings, and appurtenances shall be lowered into the trench in such a manner as to prevent any damage, particularly to the lining and coating. If such damage should occur, the coating shall be repaired to the satisfaction of the City Engineer. When required by the City Engineer, approved slings shall be used to lower the pipe. Under no circumstances shall pipe or accessories be dropped into the trench.

Pipe loaded on trucks or stacked one upon another shall be supported on wooden blocking. Pipe handled on skidways shall not be skidded or rolled against pipe already on the ground.

### **305-3 LINE AND GRADE**

Line and grade shall be maintained in accordance with the provisions of Section 304-4, "Horizontal and Vertical Alignment."

Water mains shall not vary from plan grade by more than 0.2 feet, nor from plan alignment by more than 0.2 feet.

### **305-4 TRENCH BOTTOM**

Before individual sections of pipe are lowered into the trench, bell-holes shall be hand dug for the pipe joints.

When the pipe material or field conditions require bedding, the trench shall be over-excavated in accordance with the Standard Plans and approved bedding material shall be placed and appropriately compacted.

If the bottom of the excavation is found to consist of rock, or any hard pan material that by reason of its hardness cannot be excavated to give a uniform bearing surface, said rock and other material shall be removed to at least four inches (4") below the bottom of the pipe and be refilled to grade. This shall be performed at the Contractor's expense for all labor and material, with clean sand thoroughly tamped into place.



### **305-5 PIPE LAYING**

Any earth or other rubbish which may have lodged inside any sections of pipe, valves or fittings, must be carefully wiped out so that the sections are clean as they are laid.

All open sections of pipes or fittings in the trench shall be capped, plugged or sacked and tied in an acceptable manner if left unattended for any period of time including at the end of each day. Buckets, pieces of wood or rags are not acceptable methods of plugging or capping.

Each pipe section must be given a solid uniform bearing in the bottom of the trench. Blocking or placing pipe on mounds of soil will not be permitted. Bell holes must be dug so that none of the pipe weight will rest on the bell. Bell holes must not be longer than necessary to accommodate the bell and necessary working space.

When necessary to use a short length of pipe between fittings or valves, the minimum length of pipe shall be 32" or as approved by the City Engineer. Whenever it is found necessary to cut pipe, said cut shall be made with an approved pipe cutter. The use of hammer and chisel for pipe cutting will not be permitted.

In addition, ductile iron water pipe shall be installed in accordance with AWWA M41 and PVC water pipe shall be installed in accordance with AWWA C605 and M23 except as modified herein.

#### **305-5.1 PVC PIPE INSTALLATION**

PVC pipe shall be installed in accordance with AWWA C 605 and M23 except as provided as follows:

The trench shall be excavated to a minimum of four inches below the bottom of the pipe until foundation soils are found to be firm and non-yielding. The trench will then be backfilled with sand conforming to Section 200-6. The bedding shall be graded so that the barrel of the pipe rests uniformly on the bedding throughout its entire length. Bell holes shall be hand excavated.

After the pipe has been laid and checked for proper grade, additional sand will be placed under the haunches of the pipe and to the level of the spring-line of the pipe.

- Pipe and gaskets shall be kept clean and protected against sunlight and heat damage.
- Pipe showing signs of physical damage or excessive ultraviolet exposure will be rejected and shall be immediately removed from the job site.
- The pipe shall be installed with the manufacturing label showing on the top.
- A ¼-inch gap shall remain between the end of the pipe and full insertion depth. The reference mark or stab line on the spigot end must be flush with the bell end and visible for inspection.
- Pipe ends shall be cut square, deburred, beveled, and cleaned.

- The beveled end of the pipe shall be cut off before placement into a mechanical joint.
- Minimum length of pipe for installation shall be 5 feet.
- The weight of metallic fittings and valves shall not be carried by the PVC pipe. For pipe sizes 4" through 12", the weight of such appurtenances shall be supported either by redwood blocks, precast concrete slab or blocks, or by a cast-in-place concrete cradle.

### **305-6 JOINT ASSEMBLY**

All push-on type joints shall be assembled by cleaning the groove, installing the gasket in the correct direction and making sure that the gasket is fully seated. Then all soil shall be removed from the socket and the recommended lubricant applied. Lubricant shall be non-toxic and NSF-approved. The lubricant shall be supplied in sterile containers and work conditions shall be such that the container is kept as clean as possible.

If the plain end of the pipe section was field cut, then the cut edges shall be beveled so that gasket is not damaged or dislodged during assembly. Deflections in the completed main shall only be made after each joint is assembled. In no case shall the deflection exceed the maximum as set forth by the manufacturer for the type of pipe used.

For mechanical type joints, the outside of the spigot and the inside of the pipe bell shall be thoroughly cleaned of foreign matter. The gland and gasket shall then be slipped on the spigot end of the pipe. The gasket shall be pressed evenly into the bell only after the spigot is seated in the bell. The gland shall be brought up evenly by tightening alternately the nuts spaced 180 degrees apart.

On flanged joints, the bolts shall meet the requirements of AWWA C207. The bolts shall be uniformly tightened.

### **305-7 POLYETHYLENE ENCASEMENT**

All ductile iron pipe shall be encased in loose polyethylene wrap in accordance with the provisions of AWWA C105.

### **305-8 VALVES AND HYDRANTS**

Valves and hydrants shall be set in a vertical position. Fire hydrant installation shall conform to the City of Davis Standard Plan No. 101-1, "Fire Hydrant."

The Contractor shall install the blue, two-way reflectorized pavement marker after completion of paving operations. Except as modified herein, placement shall conform to the requirements of Section 85, "Pavement Markers," of the State Specifications. The marker shall be placed one foot off of street centerline, toward the fire hydrant. When the hydrant is on a corner, a marker shall be placed on each street.



**305-9 THRUST BLOCKS**

Thrust blocks shall be poured against undisturbed soil. They shall be poured so bolts on mechanical joint and flange fittings shall be exposed. The minimum size and location of thrust blocks shall conform to City of Davis Standard Plan No. 101-2, "Thrust Block Bearing Area."

**305-10 INSTALLATION OF SERVICES**

Water services, including water meters, shall be installed in accordance with applicable City of Davis Standard Plans. Where services are to be installed in existing improved streets, the service shall be bored unless otherwise indicated in the Special Provisions.

The water service line shall be considered part of the main for the purpose of hydrostatic testing.

**305-10.1 SERVICE TAPS**

The water main shall be tapped at a position perpendicular to the axis of the main and from 0 to 45 degrees above the horizontal at a location as nearly opposite of the meter location as possible.

Service taps on water mains shall be spaced a minimum of two feet apart. Where water services connect to both sides of the water main, connections shall be alternated. Service taps shall not be made within two feet of the back of the bell or from the spigot insertion line.

The main shall be tapped with an approved type combination drilling and tapping machine equipped with a (Mueller) thread tap. The drill and tap shall be properly lubricated during the drilling and tapping process to ensure true, clean-cut threads. No direct tapped connections will be allowed on PVC or ductile iron pipe.

PVC water mains shall be tapped with a shell cutter only; hole saws shall not be used. Shell cutter shall be suitable for thick-walled PVC pipe. Shell cutter shall have a minimum of two slots and shall retain the coupon. Cutter shall direct the shavings into the throat of the shell cutter.

Saddles shall be installed on all service connections on PVC and ductile iron water mains per Section 203-8.2.

**305-10.2 SERVICE SADDLE INSTALLATION**

All services shall be attached to PVC and ductile iron water mains with saddles. Where saddles are to be installed, the tap opening shall have a diameter equivalent to the size of service to be installed.

Service saddles shall be wrapped and sealed in 8-mil minimum thickness polyethylene and backfilled with sand. Use pipe wrap tape to secure and seal the polyethylene wrap.

**305-10.3 CORPORATION STOP INSTALLATION**

Prior to threading the corporation stop into the main, the threads of the stop shall be thoroughly coated with an approved type thread lubricant.



During the threading operation, care should be taken not to thread excessively. After corporation stops are installed, 1/4" of threads on the stops shall be left exposed above the surface of the water main.

The corporation stop shall be turned to a final position which will prevent any leakage or weeping and which will allow operation of the operating key from the top, unless otherwise directed by the City Engineer.

#### **305-10.4 SERVICE LINE INSTALLATION**

The copper or polyethylene service tubing shall be installed as shown on Standard Plan 10 1-5.

Copper tubing will be rejected if it is kinked, flattened, or otherwise damaged, whether before, during or after installation.

Metallic service lines shall be encased in 8-mil minimum thickness poly tubing and backfilled with sand. Use pipe wrap tape to secure and seal the polyethylene wrap.

Metallic service lines shall also require anode installation per Standard Plan 101-12. Anodes shall be installed in a vertical position and shall be saturated with 20 gallons of water prior to backfilling.

When boring is used, the diameter of the drill to be used shall be no larger than is necessary to provide sufficient clearance for the copper tubing, without causing damage to the structural section of the street. Prior to inserting the copper tubing, the end shall be plugged in a manner that will prevent any material from entering the pipe.

Between the water main and the angle meter stop, an "S" type curve shall be introduced into the tubing in order to provide flexibility between the service and the water main. Whenever a splice is made on 1-1/2" and 2" diameter copper services, it shall be made with an approved compression connector or made with an approved brazing compound. Splicing of 1" diameter copper services will not be allowed.

When the angle meter stop has been connected, the operating key shall be upright and the axis through the stop shall be perpendicular to the top edge of the sidewalk.

No water shall be drawn through a service prior to installation of the water meter and testing of the backflow assembly.

The curb in front of residential water services shall be stamped with a "W."

#### **305-10.5 WATER METER INSTALLATION**

Water meters shall be installed in accordance with the details shown in the Standard Plans. Contractor shall install a meter box with a water meter.

Special care shall be exercised to insure proper compaction shall be made under and around the meter box so the meter remains level.

When multiple meters are installed to serve one parcel, labels shall be attached to the meter per Section 203-8.9.

### **305-10.6 TIE-IN LARGE DIAMETER WATER MAINS OR SERVICE MAINS**

All tie-ins shall be accomplished by cutting the existing main and using tees or crosses. Solid body, ductile iron sleeves shall be used to reconnect the main. Any shut-downs of the existing mains shall be as directed by the City Engineer.

Hot taps will be acceptable only if permitted by the City Engineer.

### **305-11 BLOWOFFS**

Dead-end lines, permanent and temporary, shall have a blow-off constructed per City of Davis Standard Drawing No. 101-4, Blowoff Installation, and marked with a Carsonite marker.

### **305-12 DISINFECTION AND FLUSHING**

Disinfection inspections shall begin only after passing the pressure test.

The Contractor shall not connect any new water main installation to the existing City mains, before making arrangements with the City Engineer for the testing and disinfection of the new installation. Disinfection shall be accomplished by the Contractor. The method by which such disinfection is accomplished shall be subject to the approval of the City Engineer. The procedures used for disinfection and flushing shall conform to the requirements of the AWWA C651, except where modified herein. Water from the existing distribution system or other source of supply shall be controlled so as to flow slowly into the newly laid pipe line during the application. The temporary connection to the existing system shall be isolated by installation of an approved and tested Reduced Pressure Principal (RP) backflow assembly. The method by which the chlorine is introduced into the system shall be the responsibility of the Contractor.

Sufficient chlorine shall be added to achieve 100 ppm after 3 hours of contact (slug method).

Following chlorination, all treated water shall be thoroughly flushed from the water main. All water mains shall be adequately flushed to the satisfaction of the City Engineer. Upon completion of flushing, water sample(s) will be drawn for bacteriological examination. Two consecutive sets of samples shall be taken at least 24 hours apart. Should the initial treatment fail to produce satisfactory disinfection of the piping and the pipelines as determined by the bacteriological tests, the chlorination procedure shall be repeated at the Contractor's expense until acceptable results are obtained. The initial sample cannot be taken on a Friday unless authorized by the City Engineer. The final connection to the existing City water system shall be performed within five working days of receipt of notice of satisfactory bacteriological testing.

### **305-13 PRESSURE TEST AND LEAK TEST**

Initial backfill and all reaction blocking shall be installed prior to making a hydrostatic test.



The Contractor shall leave all joints, corporation stops, curb stops and other fittings uncovered until testing has been completed.

Water for testing may be obtained at existing fire hydrants at no cost to the Contractor for water used. However, a Fire Hydrant Encroachment Permit must be obtained from the Public Works Department and the appropriate fee paid prior to such use. Backflow prevention devices shall be used at all times to isolate the new construction from the existing City water system. City will assume no responsibility for the water tightness of any water valves during the test.

The Contractor shall satisfactorily ascertain that the system is ready for hydrostatic and leakage testing prior to performance of such tests. The tests shall be performed as directed and as witnessed by the City Engineer, tested as follows:

1. Each valved section of pipe shall be slowly filled with water. An approved test pump shall be connected to the pipe in a manner satisfactory to the City Engineer. Before applying the specified test pressure, all air shall be expelled from the pipe. If hydrants or blowoffs are not available at high points, taps at points of highest elevation shall be made before the test and brass plugs inserted after completion of the test.
2. The pipe shall be subjected to a hydrostatic test pressure of not less than 150 psi.
3. All pipe, fittings, valves, hydrants and joints will be carefully examined during the test. Any cracked or defective pipe, fitting, valve, hydrant or joint discovered as a consequence of this pressure test shall be removed and replaced with sound material and the test shall be repeated until satisfactory results are obtained, as determined by the City Engineer.
4. In conjunction with the foregoing test, a leakage test shall be conducted at 150 psi. as per AWWA C600 or AWWA C605 as appropriate for the pipe material. The maximum permissible leakage during the 2 hour test shall be determined by the appropriate formula:

a. Formula for ductile iron pipe:

$$Q = \frac{L * D * \sqrt{P}}{133,200}$$

where Q = allowable leakage (gallons per hour, gph)  
 L = length of test pipe (ft)  
 D = nominal diameter (in)  
 P = test pressure (150 psi)

| Allowable leakage, gallons per hour per 1,000 feet |     |     |     |     |     |     |
|--|-----|-----|-----|-----|-----|-----|
| Diameter   | 4"  | 6"  | 8"  | 10" | 12" | 14" |
| Gallons per Hour                                   | 0.4 | 0.6 | 0.7 | 0.9 | 1.1 | 1.3 |



b. Formula for PVC pipe:

$$Q = \frac{L * D * \sqrt{P}}{148,000}$$

where Q = allowable leakage (gallons per hour, gph)  
 L = length of test pipe (ft)  
 D = nominal diameter (in)  
 P = test pressure (150 psi)

| Allowable leakage, gallons per hour per 1,000 feet |     |     |     |     |     |     |
|--|-----|-----|-----|-----|-----|-----|
| Diameter   | 4"  | 6"  | 8"  | 10" | 12" | 14" |
| Gallons per Hour                                   | 0.3 | 0.5 | 0.7 | 0.8 | 1.0 | 1.2 |

**305-14 CONNECTIONS**

Shut downs of and connections to existing City mains shall only be made in the presence and under the supervision of the City Engineer. The developer or contractor shall pay the appropriate fees prior to being connected.

Where shut downs affect water users on the existing mains, the Contractor shall schedule his shut downs to cause as little inconvenience to the users as possible. Shut down times shall be subject to prior approval by the City Engineer. The Contractor shall notify all affected users in writing at least 24 hours in advance of service interruption. The Contractor shall also request the City Engineer to notify the City Water Division personnel at least 24 hours in advance to schedule valve closing for service interruption.

Manipulation of existing valves shall only be done by or under the direction of City Water Division personnel.

**305-15 INSTALLATION OF VALVE BOXES**

Installation of valve boxes shall conform to the City of Davis Standard Drawing No. 101-3, Water Valve Box.

**305-16 ABANDONMENT OF SERVICES**

An Encroachment Permit shall be obtained by the Contractor from the Public Works Department prior to commencing work to abandon an existing water service. The work to abandon the service shall be performed in the following order:

1. Locate and expose the valve and/or corporation stop at the water main (usually in the street). Turn the valve and/or corporation stop to the closed position and secure it. Disconnect service from the valve, cap service and solder in place.
2. Locate and expose the service side end of the service to be abandoned. Remove a minimum 2' in length segment of service line to the back edge of sidewalk, curb or paved bikepath. Cut, cap and plug both ends of the service. After inspection, encase in concrete the end of the service under the back edge of the sidewalk, curb or bikepath.
3. Notify the City Engineer at least 24 hours in advance of backfill placement for inspection.
4. Backfill, compact and replace any concrete or pavement in accordance with other sections of these Specifications.

### **305-17 REPAIRING INSTALLED IMPROVEMENTS**

All PVC and DIP water mains shall be repaired per the following procedures:

- Damaged or failed pipe sections shall be removed and replaced with new pipe in the presence of the City Engineer. Replacement can be accomplished by the use of City approved ductile iron mechanical joint repair sleeves. Pipe restraints will be required.
- After the repair has been completed, the excavation shall be backfilled and compacted to grade as specified. The repairs shall then be retested per these Standards.
- At the direction of the City, the Contractor shall repair damage to the polyethylene encasement as described within AWWA C105 or shall replace all damaged polyethylene film sections.

## **SECTION 306 SEWER SYSTEMS**

### **306-1 TRENCH EXCAVATION AND BACKFILL**

All trench excavation and backfill shall be performed in accordance with the provisions of Section 304, "Underground Pipeline Construction."

### **306-2 GENERAL**

Unless otherwise specified in the Plans or Special Provisions, all pipe used for sanitary sewer lines shall be extra-strength vitrified clay pipe.

Except as noted in these Specifications, the Plans and Special Provisions, the installation of clay pipe lines shall conform to the provisions of ASTM C12.

### **306-3 LINE AND GRADE**

Line and grade shall be maintained in accordance with the provisions of Section 304-4, "Horizontal and Vertical Alignment." Sewer pipe lines shall be laid true to plan line and grade.

If field conditions exist such that the pipe may not be laid to the specified grade, the approved plans will require revisions prior to proceeding with construction.

### **306-4 BEDDING**

The trench shall be excavated to a minimum of four inches below the bottom of the pipe until foundation soils are found to be firm and non-yielding. The trench will then be backfilled with crushed rock (1/2 inch size maximum) conforming to Section 200-3. The bedding shall be graded so that the barrel of the pipe rests uniformly on the bedding throughout its entire length. Bell holes shall be hand excavated.

After the pipe has been laid and checked for proper grade, additional crushed rock will be placed under the haunches of the pipe and to the level of the spring-line of the pipe.

### **306-5 PIPE LAYING**

Pipe will be carefully inspected in the field before and after laying. Spigot ends shall be examined with particular care as the area most vulnerable to damage from handling. Pipe and other materials shall not be stored on rocks or gravel or other hard material which might damage the pipe. If any cause for rejection is discovered in a pipe, it shall be removed. Any corrective work shall be approved by the City Engineer and shall be performed at no cost to the City.

Care shall be taken when lowering pipe into the trench to protect the pipe from damage. Chains or cables are not permitted.



The interior of pipes shall be kept clean of foreign material before sections of pipe are installed and shall be protected to prevent entry of foreign materials after installation. Groundwater shall not be allowed to enter the pipe.

When connections are to be made to any existing pipe, conduit, or other appurtenances, the actual elevation or position of which cannot be determined without excavation, the Contractor shall excavate for, and expose, the existing pipe or conduit before laying any pipe or conduit. The City Engineer shall be given the opportunity to inspect the existing pipe or conduit before connection is made. Any adjustments in line or grade which may be necessary to accomplish the intent of the plans shall be made.

Pipe shall be laid continuously, without grade break, upgrade from structure to structure, with bell end upgrade.

Immediately prior to joining, the bell surface shall be wiped clean and an approved lubricant applied to both the bell and the spigot.

Suitable excavation shall be made to receive the bell end of the pipe, the joint shall not bear upon the subgrade and the bottom segment of the barrel shall be uniformly supported by direct contact with firm bedding.

Where cutting is necessary, pipe shall be cut neatly and true, with an approved cutting tool. If a piece of pipe has been cut, the Contractor shall clearly mark the usable end to show the proper amount of installation distance. Field cuts and connections shall be in accordance with the pipe manufacturer's published instructions.

Pipe shall be laid true to line and grade. Any pipe which is not in true alignment or shows any undue settlement after laying shall be taken up and laid again at the Contractor's expense.

After the joints have been made, the pipe shall not be disturbed in any manner. When a movable trench box is used, the installed pipe shall be secured to prevent it from moving when the box is moved.

At the close of the work each day, or whenever the work ceases for any reason, the end of the pipe shall be securely closed with water tight plugs or other approved means to prevent entry of foreign material or creep of the gasket joints.

Pipe joints shall be installed where lines enter and leave maintenance holes.

All pipe lines shall be approved by the City Engineer prior to placing any backfill. If backfill is placed prior to inspection, pipe shall be exposed to allow for inspection at the Contractor's expense.

The Contractor shall take all precautions necessary to prevent the "uplift" or floating of the line prior to the completion of the backfilling operation.

Sewer pipe on straight-through manholes shall be laid continuously through the manhole. Lateral lines entering the main sewer shall butt tightly against the main sewer. Pipes which are stubbed off for manhole construction or for connection by others shall be plugged or closed off with temporary

plugs. Where pipe is connected to manholes or concrete structures without using a flexible connector, connections shall be made so that the standard pipe joint is located not more than two (2') feet from the outside edge of the structure unless otherwise shown.

### **306-5.1 MARKING**

A 12-inch wide metallic backfill tape with the warning "Buried Sewer Main" shall be placed in the trench lines of all mains and services, within 12 to 24 inches of the subgrade.

Mains in unpaved areas shall be marked every 125 lineal feet with a green composite utility marker with a decal stating "Caution Buried Sewer Pipeline." Appurtenances (such as manholes, valves, ARVs, test stations, etc.) and angle points shall also be marked. Mains in landscaped areas shall be delineated with a brass marker set in an 8- inch diameter concrete cylinder.

Approved manufacturers and materials include: Calpico Inc. (Tracer Tape-Non-Detectable 12" width), Reef Industries Inc., Terra Tape Extra Stretch 450 Material, or approved equal.

### **306-6 JOINTING OF PIPE**

Pipe sections shall be closely jointed to form a smooth flowline.

Pipe joint contact surfaces shall be cleaned immediately prior to jointing. Joint lubricants and joining methods shall be performed according to the pipe manufacturer's recommendations.

For polyurethane compression joints, the spigot end shall be positioned and pressed into the bell until the pipe lengths snap together and lock to form a water-tight seal.

Jointing of plain-end pipe using rubber sleeve compression couplings with shear rings shall be made by pressing the pipe into the coupling until it butts against the stop ring or tabs. The stainless steel compressing bands shall be torqued to 70 inch-pounds minimum and shall provide uniform tension. The use of compression couplings is subject to the specific approval of the City Engineer, prior to installation.

### **306-7 SEWER SERVICES**

Installation of sewer services shall conform to the applicable Standard Plans.

### **306-8 FLUSHER BRANCHES**

Installation of flusher branches shall conform to Standard Plan No. 201-3.

### **306-9 MAINTENANCE HOLES**

Material for maintenance holes shall conform to the provisions of Section 203-10, "Maintenance Holes." Construction and placement of maintenance holes shall conform to City Standard Plan No. 201-2, "Maintenance Hole Details." Drop maintenance holes shall be used only when specifically



approved by the City Engineer. Precast maintenance hole sections shall be set level and vertical and in proper alignment with adjacent sections.

### **306-10 REPAIRS**

Necessary repairs to a sewer line shall be made by cutting out the damaged section with an approved cutting tool. The damaged section shall be replaced with like material. The ends of all pipe sections shall be cut straight and clean. Repair couplings shall be used at each connection and shall be thoroughly tightened. Reasonable care shall be exercised during repairs so as not to disturb the bedding. In any case, the repaired section shall be properly bedded prior to backfilling.

Where an excavation is made in excess of one foot below the damaged section, the repair shall be made in conformance to Standard Plan No. 201-8, "Side Sewer Repair."

All repairs shall be tested in accordance with Section 306-13 prior to acceptance.

### **306-11 INSTALLATION OF SEWER TAPS**

City forces will perform all taps on existing live City mains. The Contractor shall pay for such work on a time and materials basis. The Contractor will perform all excavation, shoring, backfilling, traffic control, and other associated work. The Contractor shall obtain the appropriate permit for a utility connection from the City, prior to performing any work.

Sewer taps shall conform to Standard Plan No. 201-5, "Sewer Line Taps."

### **306-12 CLEANING AND FLUSHING**

Prior to acceptance, sewer lines shall be hydraulically cleaned to remove debris and detect obstructions.

A high velocity hydraulic cleaner shall be used to clean all pipe segments.

Prior to starting the cleaning operation, a fine mesh wire screen shall be placed at the extreme downstream maintenance hole to prevent debris from entering the existing City sewer system. In addition, standard pipe line debris trap shall be placed at the maintenance hole immediately downstream of the portion of line to be cleaned.

The cleaning nozzle shall be introduced into the sewer at the downstream maintenance hole. All debris from the cleaning operation shall be removed by the Contractor.

Where the nozzle will not pass through the sewer, the nozzle will be retrieved, the obstruction removed, and the process will be repeated.

### **306-13 TESTING AND ACCEPTANCE**

All testing required by this section will be performed and paid for by the Contractor. Testing of services shall be conducted after installation of joint trench utility crossings.



**306-13.1 AIR PRESSURE TEST**

All sewers shall be air tested according to ASTM C828. Air testing shall take place upon completion of subgrade preparation and/or not before completion of all concrete work, or as directed by the City Engineer. The line will be cleaned and flushed in accordance with Section 306-12 prior to air testing.

Air testing equipment shall be set up so that test gauges are at ground level during the air test. The test gauge shall read and measure from 0 psi to 10 psi (full range) and be in good working order. The minimum test time, for a 1.0 psi pressure drop from 3.5 to 2.5 psi, for 100 feet of pipe is as follows:

| MINIMUM AIR TEST TIMES |                           |
|------------------------|---------------------------|
| Nominal Pipe Size      | Time (Minutes / 100 feet) |
| 4"                     | 0.3                       |
| 6"                     | 0.7                       |
| 8"                     | 1.2                       |
| 10"                    | 1.5                       |
| 12"                    | 1.8                       |
| 15"                    | 2.1                       |
| 18"                    | 2.4                       |

See the Test Method for other diameters and Test Procedures.

**306-13.2 CLOSED CIRCUIT TELEVISION INSPECTION**

After successful completion of the air test, all sanitary sewer mains will be inspected with closed-circuit television equipment. The logs shall be reviewed and approved by the City prior to final acceptance.

Defective work shall be repaired by the Contractor in a method approved by the City prior to final acceptance.

Defective work includes:

1. Breaks in the pipe;
2. Joints offset more than three-eighths inch or one percent of the inside diameter, whichever is greater;
3. Standing water or sags exceeding one-half inch in depth;

| Pipe Diameter | Allowable Depth After Construction | Allowable Depth at Warranty Inspection |
|---------------|------------------------------------|--|
| 6"            | 1/2"                               | 3/4"                                   |
| 8"            | 1/2"                               | 3/4"                                   |
| 10"           | 1/2"                               | 3/4"                                   |
| 12"           | 3/4"                               | 1"                                     |
| 15"           | 3/4"                               | 1"                                     |
| 18"           | 3/4"                               | 1"                                     |

- 4. Damaged pipe.

All repairs of defective work shall be made at no cost to the City.

Subsequent inspections due to repair of defective work discovered during the initial CCTV inspection, will be paid for by the Contractor.

**306-14 ABANDONMENT OF SERVICES**

An Encroachment Permit shall be obtained by the Contractor from the Public Works Department prior to commencing work to abandon an existing sewer service. The work to abandon the service shall be performed in the following order:

1. Locate and remove the City cleanout, including the wye. Remove a minimum 2 feet in length segment of service line to the back edge of sidewalk, curb or paved bikepath.
2. Plug both ends of the service. After inspection, encase in concrete the end of the service under the back edge of the sidewalk, curb or bikepath.
3. Notify the City Engineer at least 24 hours in advance of backfill placement for inspection.
4. Backfill, compact and replace any concrete or pavement in accordance with other sections of these Specifications.

## **SECTION 307 STORM DRAINAGE SYSTEMS**

### **307-1 TRENCH EXCAVATION AND BACKFILL**

All trench excavation and backfill shall be performed in accordance with the provisions of Section 304, "Underground Pipeline Construction."

### **307-2 PRECAST MANUFACTURED PIPE**

#### **307-2.1 LINE AND GRADE**

Line and grade shall be maintained in accordance with the provisions of Section 304-4, "Horizontal and Vertical Alignment." Storm drainage lines shall not vary from plan grade by more than 0.03 feet, nor from plan alignment by more than 0.2 feet.

#### **307-2.2 PLACEMENT**

The bottom of the trench shall be graded in such a manner that the pipe barrel bears uniformly on solid material throughout its entire length.

Pipe will be carefully inspected in the field before and after laying. If any cause for rejection is discovered in a pipe, it shall be removed. Any corrective work shall be approved by the City Engineer and shall be at no cost to the City. Any pipe which is not in true alignment or shows any undue settlement after laying shall be taken up and laid again at the Contractors expense.

When connections are to be made to any existing pipe, conduit, or other appurtenances, the actual elevation or position of which cannot be determined without excavation, the Contractor shall excavate, and expose the existing pipe or conduit before connection is made. Any adjustments in line or grade which may be necessary to accomplish the intent of the Plans shall be made.

Pipe shall be laid upgrade with the bell or collar ends of the pipe upgrade, unless otherwise authorized by the City Engineer.

Where field cutting of pipe is necessary, pipe shall be cut neatly and true.

Subsequent inspections due to repair of defective work discovered during the initial CCTV inspection will be paid for by the Contractor.

After joints have been made, the pipe shall not be disturbed in any manner.

At the close of work each day, or whenever the work ceases for any reason, the end of the pipe shall be securely closed, unless otherwise permitted by the City Engineer.

All pipelines shall be approved by the City Engineer prior to placing any backfill.



The interior of the pipe shall be kept free of all dirt, excess mortar, or other foreign material as the pipe laying progresses, and shall be left clean at the completion of the work.

### **307-2.3 JOINTS, CONCRETE TONGUE AND GROOVE PIPE**

Concrete tongue and groove pipe shall be jointed using one of the two following methods.

#### **307-2.3.1 MORTAR JOINTS**

Cement mortar shall conform to Section 201-5. Cement mortar shall be used within thirty (30) minutes after water has been added. The groove of the downstream pipe shall be thoroughly cleaned and then wetted with a wet brush to ensure a proper bond. A layer of mortar shall be uniformly applied to the lower half of the groove. A small excavation shall be made below the joint and filled with mortar. The tongue end of the pipe being laid shall be thoroughly cleaned and then wetted. While the pipe is in a horizontal position, a layer of mortar shall be applied uniformly to the upper half of the tongue.

The tongue shall be inserted into the groove until the mortar is squeezed out on the interior and exterior surfaces. The interior of the joint shall be brushed smooth and the exterior of the joint shall be completely filled. A band of mortar extending completely around the joint and connecting with the mortar previously placed below the joint shall be carefully applied and smoothed. The completed exterior of the completed joint shall immediately be protected from air and sunlight with an initial covering of canvas, burlap, plastic, heavy paper, or a curing compound conforming to Section 201-4. Any permeable covering shall be kept moist for at least 48 hours.

For pipe 27 inches in diameter and larger, the interior of the joints shall be filled with mortar from inside the pipe. Within 12 hours from the time the pipe was placed. In order to prevent the mortar from setting up too rapidly, the ends of the pipe shall be covered to prevent the flow of air through the pipe while the mortar is plastic.

#### **307-2.3.2 JOINTS USING JOINT SEALANT**

Rubber-based joint sealant shall conform to the provisions of Section 202-3, "Joint Sealant for Concrete Pipe." The sealant shall be applied in conformance with the manufacturer's recommendations. The joint surfaces shall be clean and dry prior to application. Heat shall be applied as necessary to dry wet surfaces. The recommended joint primer adhesive shall be used on all horizontal installations of pipe. For pipe 27 inches in diameter or larger, two coils of sealant shall be used. After the pipe is positioned, the pipe ends shall be brought together to squeeze the sealant until it forms a watertight seal.

### **307-2.4 JOINTS, CONCRETE BELL AND SPIGOT PIPE**

Concrete bell and spigot pipe shall be jointed using rubber gasket joints conforming to the provisions of ASTM C443. The gaskets shall be flexible and able to withstand expansion, contraction and settlement.

All rubber gaskets shall be stored in as cool a place as practicable, preferably at 70°F. or less. In no case shall the rubber gaskets be exposed to the direct rays of the sun for more than 72 hours.

Rubber gaskets, of the type requiring lubrication, shall be lubricated with the lubricant recommended and supplied by the manufacturer of the pipe.

The sections of pipe shall be laid such that the inside surfaces form a smooth and regular surface. The maximum allowable offset of each joint shall be three-eighths inch.

Each joint shall contain a solid gasket which shall be the sole element providing water-tightness of the joint. Each joint shall be watertight and flexible.

During laying and jointing operations, mating surfaces of each joint shall be thoroughly cleaned, lubricated and properly assembled, in accordance with the manufacturer's recommendations, and in accordance with good construction practice. Feeler gauges shall be used to check the gasket location after assembly of the joint, when required by the City Engineer.

### **307-2.5 JOINTS, ASBESTOS-CEMENT PIPE**

A small excavation shall be made at the joint so that the collar of the pipe does not bear on the bottom of the trench. The gasket and gasket seat inside the collar shall be wiped clean before the gasket is inserted. A thin film of lubricant shall be applied to the gasket and the outside of the pipe end to be inserted into the collar. Lubricant other than that furnished with the pipe shall not be used unless prior approval has been given by the City Engineer.

The ends of the pipe shall then be forced into the collar to complete the joint.

## **307-3 CAST-IN-PLACE NON-REINFORCED CONCRETE PIPE (CIPP)**

### **307-3.1 GENERAL**

Cast-in-place, non-reinforced concrete pipe is conduit made of Portland cement concrete cast in a monolithic pour in a properly prepared trench, using equipment specifically designed for such construction. The equipment the Contractor proposes to use shall be approved by the City Engineer. The Contractor may be required to furnish evidence of successful operation on prior work.

All CIPP shall be designed by the Project Engineer to resist all loading conditions. The details of the CIPP design will be shown on the approved Improvement Plans. The minimum allowable thicknesses shall be as follows:



| CIPP MINIMUM WALL THICKNESS |                        |
|-----------------------------|------------------------|
| Internal Diameter           | Minimum Wall Thickness |
| 24" to 30"                  | 3"                     |
| 36"                         | 3-1/2"                 |
| 42"                         | 4"                     |
| 48"                         | 5"                     |
| 54"                         | 5-1/2"                 |
| 60"                         | 6"                     |
| 66"                         | 6-1/2"                 |
| 72"                         | 7"                     |
| 84"                         | 8"                     |
| 96"                         | 9"                     |
| 108"                        | 10"                    |
| 120"                        | 12"                    |

CIPP shall be constructed only:

1. In the presence of the City Engineer, and
2. In ground capable of standing unsupported from the bottom of the trench to the top of the pipe without sloughing, or,
3. In fill when it can be demonstrated to the satisfaction of the City Engineer that the fill will adequately support the pipe.

If the City Engineer determines that soil conditions are unsuitable for constructing CIPP, or that sloughing of the trench may occur to the extent that earth or other objectionable material could be included in the concrete, the Contractor shall install reinforced concrete pipe or an acceptable alternate as directed by the City Engineer. All costs for this substitution shall be borne by the Contractor.

Unacceptable portions of CIPP shall be replaced or repaired to the satisfaction of the City Engineer at no additional cost to the City.

The Contractor shall provide adequate means of providing fresh air delivery to the inside of the pipe. This shall be for the use of workers during construction and for the use of the City Engineer during inspection. The methods and quantities of fresh air delivery shall be suitable for the purpose and shall conform to applicable requirements of local, state and federal rules, regulations, laws and ordinances.

**307-3.2 MATERIALS**

Concrete shall conform to the requirements of Section 203-2.3, "Concrete for Cast-In-Place Pipe."



### **307-3.3 EXCAVATION**

Trenches shall be excavated on the alignment and to the grades shown on the Plans. The subgrade shall be fine graded to the tolerances specified in Section 307-3.6.5. No concrete shall be placed unless the trench is within the specified grade and alignment tolerances.

The trench shall be wide enough to accommodate the equipment and provide the required wall thickness of the pipe. The bottom of the trench shall be shaped to serve as the outside form for the pipe. The trench must provide full, firm and uniform support over the bottom 210° of the pipe, which is referred to as the “trench form.”

Where isolated rock or other unsuitable material is encountered within the trench form, it shall be removed. If the rock is too large to be removed by hand, all portions of the rock within six inches of the lower 90° of the trench form shall be removed. The void shall be filled with concrete placed in a monolithic pour with the pipe or backfilled with compacted soil.

At the time of concrete placement, all soils to be in contact with CIPP shall be moist, but shall not contain standing, seeping or flowing water. Provisions shall be made to de-water the trench so that flowing or standing water is eliminated. At no additional cost to the City, the Contractor may place a layer of one inch crushed rock, six inches thick at the trench invert to assist in water control.

### **307-3.4 PLACEMENT**

Prior to placing any pipe, the Contractor shall secure the City Engineer’s written approval of the excavated trench.

#### **307-3.4.1 GENERAL**

Pipe shall be constructed with equipment specially designed for constructing cast-in-place concrete pipe. The Contractor shall furnish evidence of successful operation of the proposed equipment on other work. Equipment not suitable to produce the quality of work required for the pipeline will not be permitted to operate on the Work.

Concrete placement shall be in accordance with Section 303, except as provided herein. The flow line grade and alignment of the finished pipe shall conform to the tolerances stated in Section 307-3.6.5. All forms shall be cleaned of laitance and old concrete before being used on the job and in between placement operations.

The concrete shall be placed around the full circumference of the pipe in one operation by means of fixed forms and traveling forms. The internal fixed forms shall be of sufficient strength to withstand the vibrating or tamping of concrete. Workers shall not walk or stand on the placed concrete. The concrete shall be vibrated, tamped or worked with suitable devices until the concrete has been consolidated and completely fills the forms.

Where junction structures are to be constructed, the concrete shall be placed continuously through the structure locations, in accordance with the City Standard Plan No. 201-2, “Maintenance Hole Details.”

**307-3.4.2 CONSTRUCTION JOINTS**

A construction joint shall be constructed when placement is stopped for such time that initial set is likely to occur. The fresh concrete shall be cut off so that the end of the pipe is square. Dowels, consisting of No. 4 reinforcing bar, 24 inches in length, shall be inserted into the fresh concrete. They shall be inserted 12 inches into the fresh concrete at intervals not to exceed 18 inches.

A concrete collar shall be placed in a monolithic pour around the old concrete upon resumption of placement operations. This collar shall be formed by excavating around the old concrete. The minimum dimensions shall be six inches thick and twelve inches in length, or one and one-half times as thick as the wall thickness and four times as long as the wall thickness, whichever is greater. The old concrete shall be cleaned of surface laitance and aggregate shall be exposed.

Precast manufactured pipe shall be joined to CIPP using a reinforced concrete collar conforming to the details of City Standard Plan No. 401-2, "Concrete Collar for Joining RCP and CIPP."

**307-3.4.3 FORM REMOVAL**

Internal fixed forms shall remain in place until the concrete is self-supporting, after which they may be loosened but shall not be removed until at least six hours after placement. As soon as possible thereafter, the forms shall be removed to facilitate inspection and prompt repair.

**307-3.4.4 FINISHING**

The interior of the pipe shall be at least as smooth as a wood-float finish except for the form lap ridges permitted in Section 307-3.6.4.

**307-3.4.5 CURING**

Immediately after concrete placement, the exposed top portion of the pipe shall be cured by placing a polyethylene film at least .0015-inch (1.5 mil) thick so as to completely cover the top surface, or such other method as approved by the City Engineer.

In order to minimize the concrete shrinkage, all openings in the pipe shall be covered for at least five days immediately after placement, except at locations where work on the pipe is required, and only during the period that such work is actually in progress.

**307-3.4.6 REPAIRING**

After the internal fixed forms have been removed, the inside of the pipe shall be inspected. All rock pockets, blisters, voids or similar defects shall be repaired immediately in a manner approved by the City Engineer.

After placement of the backfill, the Contractor and the City Engineer shall reinspect the inside of the pipe. Cracks less than 0.01 inch in width shall be painted with a cement paste. Transverse cracks 0.01 inch or more in width, and longitudinal cracks 0.01 inch or more in width and less than 12 inches in length shall be repaired. The method of repair and the material used shall be approved by the City Engineer.



Longitudinal cracks exceeding 0.01 inch in width and 12 inches or greater in length shall be cause for rejection of the cracked pipe. If such cracks occur intermittently in more than 25 percent of the length of any reach of pipe, the entire reach is subject to rejection. Reaches subject to rejection shall either be removed and replaced or shall be strengthened in a manner approved by the City Engineer at the expense of the Contractor.

### **307-3.5 BACKFILL**

Placement of backfill shall conform to the requirements of Section 304, "Underground Pipeline Construction," and the City Standard Plan No. 201-1, "Trench Details." The equipment and methods used in placing backfill shall not damage or overload the pipe.

Backfilling operations will not be permitted until the concrete attains at least the strength specified on the Plans or in the Special Provisions. The Contractor may elect to place backfill prior to the City Engineer's 28-day strength tests, provided it can be shown to the satisfaction of the City Engineer, that the required strength has been attained.

### **307-3.6 DIMENSIONS AND TOLERANCES**

#### **307-3.6.1 MINIMUM SIZE CIPP**

The minimum size of CIPP shall be 24 inches, inside diameter.

#### **307-3.6.2 DIAMETER**

The actual internal diameter at any point shall not be less than specified on the Plans. If the diameter is found to be less than that specified, the work shall be stopped and the necessary adjustments made. The City Engineer may require the pipe to be removed and replaced with pipe of the correct diameter. All such adjustments or replacements shall be at the expense of the Contractor.

#### **307-3.6.3 WALL THICKNESS**

The wall thickness at any point shall not be less than specified. Failure to meet the thickness requirements shall be cause for rejection. The grade and alignment shall be controlled so that the wall thickness of the pipe is symmetrical.

#### **307-3.6.4 OFFSETS AND INDENTATIONS**

Transverse and longitudinal form offsets and form strut bearing plate indentation shall not exceed three-eighths inch for pipe with specified internal diameter of 72 inches or less, and one-half inch for pipe with specified internal diameter greater than 72 inches.

Offsets or indentations in excess of these limits shall be repaired as directed by the City Engineer.



**307-3.6.5 LINE AND GRADE**

Line and grade shall be maintained in accordance with the provisions of Section 304-4, "Horizontal and Vertical Alignment."

Departure from and return to established grade shall not exceed one-eighth inch per linear foot ( $\pm$ one percent slope) and maximum departure shall not exceed one-half inch (0.04 foot). Maximum departure from established alignment shall not exceed two and one-half inches (0.2 foot) on tangents and four inches (0.3 foot) on curves. Departure from and return to established alignment shall not exceed one-fourth inch per lineal foot (1 degree angular).

If the departure exceeds the maximum allowed, the work shall be stopped and the Contractor shall make the necessary adjustments. The City Engineer may require the affected portions of the conduit to be removed and replaced at the proper grade and alignment.

**307-3.6.6 LINES ADJACENT TO EXISTING WATER LINES**

There shall be a minimum of six inches of vertical clearance between storm drain lines and water lines. If this clearance requirement is unobtainable, the City Engineer may reduce the clearance requirement to a minimum of two inches. In this event a manufactured nonmetallic "saddle" type spacer shall be used between the storm drain and the water line.

**307-3.7 TEST REQUIREMENTS****307-3.7.1 SEQUENCE OF SAMPLING AND TESTING**

All sampling and testing shall be performed by the City Engineer. The initial testing and sampling during placement operations shall be performed at no cost to the Contractor. The Contractor shall be responsible for the cost of all additional testing which is required as a result of unsatisfactory initial test results.

During the concrete placing operation, slump tests shall be performed, concrete cylinder specimens shall be molded for strength determination, and the thickness of placed material shall be measured. If the concrete does not meet the required 28-day strength, cores shall be obtained from the completed pipe. Cores shall be used to determine thickness and compressive strength. If the strength of these cores fails to meet the design requirements, the affected sections of pipe shall be rejected and replaced at no cost to the City.

The City Engineer will determine the number and location of core samples and related tests. The location shall be identified by station, and where applicable, the angle from vertical measured clockwise facing up-station.

**307-3.7.2 SLUMP TESTS**

Slump tests will be required for each set of test cylinders and shall be performed in accordance with ASTM C 143.

### **307-3.7.3 CONCRETE CYLINDERS**

Concrete cylinders shall be molded and cured in accordance with ASTM C31 and tested in accordance with ASTM C39, except as modified herein. Cylinder molds and caps shall be provided by the concrete supplier.

The City Engineer shall prepare and test a sufficient number of concrete cylinders to verify the strength of the concrete mix. Cylinders shall be prepared and tested in multiples of three each. The first cylinder of each set shall be tested to determine seven day strength, and the second tested to determine 28-day strength. If the second cylinder test fails the strength requirement, then the third cylinder shall be tested at 45 days after concrete placement.

Backfill shall not be placed until so approved by the City Engineer.

Copies of all test data and reports shall be provided to the Contractor.

### **307-3.7.4 THICKNESS**

The City Engineer will determine the appropriate method for measuring the in place wall thickness of the pipe. The methods used may include, but not be limited to, probing through wet concrete, probing through drilled holes, or excavating holes using a shovel.

After measurement, the Contractor shall patch all holes.

### **307-3.7.5 CONCRETE CORES**

The City Engineer reserves the right to require the Contractor to perform all coring operations. Cores, where required, shall be obtained from the pipe and tested in accordance with ASTM C42. The cores shall have a length-to-diameter ratio of not less than one. The diameter of cores shall be at least three times the maximum size of the aggregate used in the concrete, except where the wall thickness is such that the length-to-diameter ratio will be less than one, in which case the core diameter may be reduced to 2.5 times the maximum aggregate size used. There shall be at least four cores taken for each 200 linear feet, or fraction thereof, of pipe represented by any cylinder that fails the required tests. Cores shall be taken at the following points at stations selected by the City Engineer: One through the crown, one through the invert, and two in the lower half of the pipe 450 from the vertical. The City Engineer may require additional cores at any location. The Contractor shall patch all core holes in such a manner that the patch will be permanent, will not leak, and will have a smooth finish flush with the interior surface of the conduit. All costs of coring, testing and patching core holes shall be paid by the Contractor.

## **307-4 STREET UNDERDRAINS**

### **307-4.1 TIMING OF CONSTRUCTION**

Street underdrains shall not be installed until all other underground utility construction is complete. It shall be installed after the street subgrade in the vicinity of the underdrain has satisfactorily passed testing for compaction and grade.



**307-4.2 LOCATION**

Street underdrains shall be installed on the uphill side of all drop inlets when so required by the City Engineer. Low points (sags) will require an underdrain extending from both sides of the drop inlet. The minimum distance for Street underdrains shall be 100 feet extending upstream from all drop inlets. The underdrains shall be installed on both sides of the street. The underdrains shall be sloped toward the drop inlet at the same slope as the flowline of the gutter.

The underdrain shall be installed in accordance with the details of Standard Plan #401-3. It shall be placed substantially under the lip of gutter line. Minor deviations from this location will be approved in the field by the City Engineer. Any substantial deviation from this location requires special approval of the City Engineer.

**307-4.3 EXCAVATION**

The trench shall be excavated neat and true to line and grade, with vertical trench walls. All trench spoils shall be incorporated in the unfinished portions of the street subgrade or removed from the street right-of-way. Any overexcavation or variation in trench dimensions shall be accommodated by backfilling the subject area with drain rock.

**307-4.4 FABRIC PLACEMENT**

After completion of excavation, geotextile fabric shall be placed in the trench. Nonwoven geotextile fabric shall be Mirafi 150N, Propex Geotex 501, or approved equal. The width of the fabric shall be sufficient to encompass the drain rock without parallel seams or splices. Splices perpendicular to the trench shall be made with a minimum of 12 inches of overlap. The fabric overlap at the top of the drain rock shall be at least six inches.

**307-4.5 DRAIN ROCK AND PIPE PLACEMENT**

The pipe shall be bedded on one inch of drain rock. The pipe shall be placed in the trench with the perforations down. The remainder of the trench shall be backfilled with drain rock and the fabric folded over the top. The drain rock shall be compacted by suitable methods.

The top of the fabric shall be no more than two inches below the subgrade, provided that the remainder of the trench is backfilled with drain rock to the level of the finish subgrade.

**307-4.6 DROP INLET CONNECTION**

The pipe shall connect to the drop inlet. Connections to storm drain pipes will not be allowed. The hole in the wall of the drop inlet shall be made by a method that produces a clean and neat entrance with minimal cracking and spalling of the concrete. The hole shall not exceed six inches in least dimension. The annular space between the pipe and hole shall be filled with non-shrink grout. The pipe shall protrude at least one inch into the basin.



**307-4.7 END OF LINE CLEANOUT**

A cleanout shall be installed at the end of each run of street underdrain. The cleanout at the end of the line shall be installed in the pavement area immediately adjacent to the lip of gutter. In order to accommodate the cleanout box, one 45° (1/8 bend) fitting shall be used to horizontally and vertically angle the pipe toward the box.

## **SECTION 308 TRAFFIC STRIPING, DELINEATION AND SIGNS**

### **308-1 TRAFFIC STRIPING AND MESSAGES**

This work shall consist of painting traffic stripes, painting traffic messages and markings, including applying glass beads, and applying pavement markers.

#### **308-1.1 PAVEMENT OVERLAY WORK**

Prior to any pavement overlay work, the Contractor shall prepare a detailed record (i.e., plan or list) of all existing striping, pavement markers and pavement messages. This record shall reference suitable physical features, such that the existing traffic delineation can be recreated upon completion of overlay operations. Copies of this record shall be reviewed and approved by the City Engineer prior to commencement of overlaying.

Upon completion of the overlay operations, the Contractor shall reproduce the striping to its original layout

#### **308-1.2 NEW WORK**

The Contractor shall accurately layout all traffic delineation from the approved plans. The City Engineer will review and approve the layout prior to commencement of placement operations. Alternate methods of layout may be used by the Contractor, subject to the approval by the City Engineer, for streets that are not open to general traffic.

Where new streets are open to general traffic prior to completion of final striping, then temporary delineation and traffic control shall be provided. In these cases, alternate methods of layout will not be approved.

#### **308-1.3 TEMPORARY DELINEATION**

Attention is directed to the provisions of Section 7-7, "Public Safety." The Contractor shall provide temporary delineation and traffic control, unless the subject streets are closed to general traffic.

Temporary delineation and traffic control shall be in place at the conclusion of each working day. Strips of reflective tape, at least eight inches in length, shall be provided at intervals not to exceed fifty feet, for all centerlines, lane lines and bike lanes. Continuous stop bar shall be provided at all stop signs.

#### **308-1.4 REMOVAL OF EXISTING STRIPING AND PAVEMENT MARKERS**

Whenever the plans require alteration of striping on an existing street, all existing striping and pavement markers shall be removed using striping grinders, sandblasting or other appropriate methods in the case of pavement markers. Care shall be exercised to minimize damage to the existing

pavement when a pavement overlay will not accompany the new striping or pavement markers installation. Existing pavement markers shall be removed using appropriate methods prior to any pavement overlay work.

The entire area where striping has been ground shall receive a seal coat in accordance with Section 202-2, "Emulsified Asphalt."

### **308-1.5 PERMANENT STRIPING AND MARKING**

#### **308-1.5.1 GENERAL**

Painting shall be performed only when weather conditions are favorable and suitable for such application. Traffic paint shall be applied to dry surfaces.

Painting shall not be performed when the atmospheric temperature is below 50°F; when freshly painted surfaces may become damaged by rain, fog or condensation; or when it can be anticipated that the atmospheric temperature will drop below 50°F during the drying period.

The Contractor shall clean surfaces to be painted as deemed appropriate. All loose dirt and other deleterious materials shall be removed. All existing pavement markers in overlay areas shall be removed and disposed in an appropriate manner.

#### **308-1.5.2 EQUIPMENT**

Mechanical means shall be used to paint traffic stripes and pavement markings and to apply the glass beads for traffic stripes.

All equipment used in the application of traffic stripes and pavement markings shall produce stripes and pavement markings of uniform quality that conform to the specified requirements.

Stencils and hand spray equipment shall be used to paint pavement markings. Stencils shall conform to the specified dimensions. The Contractor shall borrow the City's stencils for all pavement legends. Borrowed stencils shall be returned in substantially the same condition as when initially borrowed.

Mechanical mixers shall be used to mix paint. Prior to applying, the paint shall be mixed a sufficient length of time to thoroughly mix the pigment and vehicle together, and shall be kept thoroughly agitated during its application.

#### **308-1.5.3 LAYOUT**

Layout shall be performed prior to permanent painting and shall consist of "cat-tracking" the surface. Cat-tracking shall consist of placing spots of paint not more than three inches in width and not more than five feet apart along the line established. Paint for cat-tracks shall be the same as that used for the traffic stripe for which it is placed.

All layout work shall be approved by the City Engineer prior to permanent painting.



### **308-1.5.4 APPLICATION**

Each coat of paint for any traffic stripe, including glass beads where required, shall be applied in one pass of the striping machine, regardless of the number, widths, and patterns of individual stripes involved. Glass spheres shall be incorporated in traffic stripes immediately after application of the paint.

The paint and glass beads shall be applied so as to produce a uniform wet film thickness of 15 mils (equal to one gallon of paint per 107 square feet). The glass beads shall be applied at a rate of 5 pounds per gallon of paint.

The completed stripes shall have complete uniform coverage and well defined edges. The stripe shall not deviate more than 1/4" in width.

Drips, overspray or improper markings shall be immediately removed from the pavement surface by blast cleaning or methods approved by the City Engineer, at the Contractor's expense.

Paint shall not be heated to a temperature greater than 160°F. A 3"-wide black stripe shall be painted between the two outside 4"-wide yellow stripes of a double traffic stripe.

### **308-1.5.5 CLEANUP**

The Contractor shall not clean the painting equipment such that any leftover paint or cleaning fluids run onto any portion of the public roadway and adjacent dirt areas. The Contractor shall cleanup and remove any spillage or dripping due to equipment cleaning. All cleaning and disposal of appurtenant liquids and solids shall be performed in accordance with all applicable rules, regulations, laws and ordinances.

## **308-2 TRAFFIC SIGNS**

### **308-2.1 STANDARD PLANS**

All traffic sign installations shall conform to Standard Plan No. 30 1-9, "Traffic Signing Details."

### **308-2.2 POST INSTALLATION**

Posts shall be placed in holes excavated in the ground. Holes shall be excavated 3" deeper than the required depth for the bottom of the posts as shown on the Plans. The space around posts shall be backfilled to finished ground with Class "C" concrete. The concrete shall be consolidated by spading with a shovel. Material excavated from the hole shall be disposed of in an appropriate manner.

Posts shall not be spliced, except as allowed at ground level per the Standard Plans. Posts shall be installed plumb.

### **308-2.3 SIGN PANEL INSTALLATION**

Sign panels shall be installed using the appropriate brackets, fasteners and tools as supplied by the sign manufacturer. Mounting hardware supplied by the sign manufacturer will be the only type

allowed. Any chipping or bending of sign panels shall be considered as sufficient cause to require replacement of panels at the Contractor's expense.

Signs shall not be attached directly to sign posts or other poles by drilling a hole through said post or pole. All signs shall be attached by using appropriate clamp-on U-brackets or straps. Parking regulatory signs which are 12" in width and 18" in height shall be attached to the post using a post top L-bracket. Where appropriate, street name signs shall be mounted to electrolier poles using a wing bracket which is strapped to the pole.

All sign panels shall be vertical and plumb after attachment to the post. Sign panels shall be oriented so as to be most visible to oncoming traffic, as directed by the City Engineer.

## **SECTION 309 STREETLIGHT INSTALLATION**

### **309-1 GENERAL**

Streetlight work shall consist of furnishing, installing, modifying, and removing one or more streetlighting systems, including provisions for future systems, in the public right-of-way, as shown on the Plans, as provided in these Specifications, and the Special Provisions. All systems shall be complete and in operating condition prior to acceptance of the Contract.

Material shall conform to the provisions of Section 206, "Streetlight Materials." All incidental parts which are not shown on the Plans, or specified herein or in the Special Provisions, and which are necessary to complete or modify the existing system, shall be furnished and installed as though such parts were shown on the Plans or specified herein.

### **309-2 REGULATIONS AND CODES**

All work shall be performed in accordance with the listing in Section 206-1.1, "Regulations and Codes."

The project owner (whether the City or a private developer) shall obtain a building permit, including payment of fees, for any new metered electrical services. The project owner shall obtain the PG&E short circuit rating for submittal with the building permit application.

### **309-3 SHOP DRAWING SUBMITTALS**

The Contractor shall submit to the City Engineer, for review and approval, a list of equipment and materials proposed for installation, as specified in the Plans and Specifications. This list shall be submitted and reviewed in accordance with the provisions of Section 5-2, "Plans and Shop Drawings."

When electrical work is of standard manufacture and constructed according to the Plans, the submission of detailed drawings and diagrams is not required.

Prior to acceptance, the Contractor shall furnish copies of the manufacturer's instruction sheets, parts lists, warranties and guarantees, for all materials used in the work.

### **309-4 PROTECTION OF PROPERTY**

#### **309-4.1 GENERAL**

The Contractor shall comply with the provisions of Section 7-9, "Preservation of Property."



### **309-4.2 EXISTING LIGHTING SYSTEMS**

The Contractor shall notify the City Engineer at least two working days prior to performing any work on existing systems.

Lighting system shutdowns shall not interfere with the regular lighting schedule, unless otherwise permitted by the City Engineer.

The Contractor shall ascertain the exact location and depth of existing conduits, pull boxes and other electrical facilities before using any tools or equipment that may damage such facilities or interfere with any electrical system.

Where roadways are to remain open to traffic and existing lighting systems are to be modified, the lighting systems shall remain in operation and the final connection to the modified circuit shall be made so that the modified circuit will be in operation by nightfall of the same day.

### **309-4.3 REMOVING AND REPLACING IMPROVEMENTS**

Improvements such as sidewalks, curbs, gutters, Portland cement concrete and asphalt concrete pavement, underlying material, lawns and plants, and any other improvements removed, broken or damaged by the Contractor's operations, shall be replaced or reconstructed with the same kind of material as found on the work or with materials of equal quality. Such improvements shall be left in a serviceable condition.

Whenever a part of a square or slab of existing concrete sidewalk, curb, gutter, or driveway is broken or damaged, the entire square or section of slab shall be removed and the concrete reconstructed.

The outline of all areas to be removed in Portland cement concrete sidewalks and driveways and in pavements shall be sawcut to a minimum depth of 0.17 foot prior to removing the sidewalk, driveways and pavement material. Cuts shall be neat and true along score lines, with no damage outside the removal area.

### **309-4.4 SALVAGED ELECTRICAL EQUIPMENT**

Existing equipment removed and not reused shall remain the property of the City. Salvaged equipment shall be delivered to the City's Corporation Yard (1717 Fifth Street) unless otherwise specified in the Plans and Specifications.

## **309-5 UNDERGROUND CONDUIT INSTALLATION**

### **309-5.1 GENERAL**

All underground conduit construction shall conform to the provisions of Section 304, "Underground Pipeline Construction," and the requirements of this Section.

## **309-5.2 EXCAVATION**

### **309-5.2.1 GENERAL**

The trenches shall not be excavated wider than necessary for the proper installation of the electrical appurtenances and foundations. Excavation shall not be performed until immediately before installation of conduit and other appurtenances. Where excavation is in existing streets, the excavated material shall be cleaned up and disposed of properly, immediately following the excavation operation.

The excavation work shall be performed so as to avoid any unnecessary damage to streets, sidewalks, landscaping, or other existing improvements.

### **309-5.2.2 ROCK-WHEEL TRENCHING**

The Contractor may use a Rock-wheel trencher in existing paved streets. Trenches shall be excavated by a machine that will produce smooth edge cuts in the pavement and will move at a speed in excess of four feet per minute while cutting pavement. The trenching machine shall be shielded to prevent loose material from being thrown away from the machine. Loose material deposited on the pavement behind the cutting machine shall be immediately removed from the pavement and the pavement cleaned to allow the passage of traffic. The cutting machine and cleanup operation shall be located within the lane closed to traffic. The lane shall be reopened as soon as the work has moved sufficiently to clean and reopen it. Backfill shall commence immediately after conduits have been installed and approved by the City Engineer. Streets shall be open to traffic at the end of each day's work. Temporary street resurfacing material shall be placed over the surface of the trench area daily.

## **309-5.3 CONDUIT INSTALLATION**

Conduit shall be installed for all conductors, except where conductors are inside poles. All conduit shall be installed underground, shall not be smaller than one inch nominal diameter, and shall be of the sizes shown on the Plans or as provided in the Special Provisions. At the Contractor's option and expense, conduit of a larger size than that shown or specified may be used, provided that the larger size is used for the entire length of the run from outlet to outlet. Reducing couplings will not be permitted. New conduit shall not pass through streetlight foundations.

Underground conduit placed within road right-of-way areas (roadway) shall be 30 inches deep, measured from the top of conduit to the pavement surface. Conduits crossing under existing roadways must be jacked or drilled unless otherwise approved by the City Engineer. Conduits placed in roadways under construction shall be in trenches with a maximum width of six inches.

All conduit installation in new roadways shall be performed prior to completion of subgrade. Conduit placed parallel with roadways shall be approximately one foot behind the sidewalk.

PVC conduit placed outside the roadway shall have a minimum cover of 24 inches. Metal conduit placed outside the roadway shall have a minimum cover of eighteen inches.

In all conduit systems, installation shall permit the wire to be drawn into the conduit without injury. In any case, bends in conduit shall not be less than six times the inside diameter of the conduit.



The ends of all metal conduits shall be well reamed to remove burrs and rough edges. Field cuts shall be made square and true so that the ends will butt or come together for the full circumference thereof. Slip joints or running threads will not be permitted for coupling conduit. When a standard coupling cannot be used, an approved threaded union coupling shall be used. The threads on all metal conduit shall be well painted with a good quality lead or rust preventive paint before couplings are jointed. All couplings shall be tightened until the ends of the conduits are brought together. A good grounding connection shall be made throughout the entire length of the conduit run. Where coating on conduit has been injured in handling or installing, damaged areas shall be thoroughly painted with an approved rust preventive paint.

Where PVC conduit is used in lieu of rigid galvanized conduit, ends of conduit must be clean and free of burrs before gluing them together.

Conduit terminating in standards or pedestals shall extend a minimum of three inches above the top of finished concrete foundation, and shall be sloped toward the hand hole. Conduit entering concrete pull boxes shall terminate two inches inside the wall of the box and not less than three inches above the bottom and shall be sloped to facilitate pulling of the cable. Conduit entering through the bottom of a pull box shall be located near the end walls to leave the major portion of the box clear. At all outlets, conduit shall enter from the direction of the run. All conduit ends shall be provided with an approved bonding type bushing, except for PVC conduit.

#### **309-5.4 PULL BOX INSTALLATION**

Pull boxes shall be installed at the locations as shown on the plans, as specified herein, and as directed by the City Engineer.

The distance between pull boxes or between streetlights and pull boxes shall not exceed 200 feet. Additional pull boxes shall be installed, at the above spacing, when a conduit run exceeds 200 feet. A Pull Box shall be installed immediately adjacent to the Pacific Gas and Electric service point for each conduit run.

The Contractor may install, at the Contractor's expense, such additional pull boxes that may facilitate the work.

Pull boxes shall be installed so that the covers are level with the top of the curb, pavement, sidewalk, or level with the surrounding ground when there is no established grade. Excavations for the installation of pull boxes shall be at least 18 inches below the bottom of the pull boxes and at least six inches larger on all sides of the pull boxes. This area outside the pull box shall be filled with pea gravel for drainage.

#### **309-5.5 BACKFILL**

##### **309-5.5.1 STREET AREAS**

All backfill material and methods within the street right-of-way shall conform to the provisions of Section 304-6, "Backfill and Compaction." Said Section contains specific requirements for backfill within three feet of the finished subgrade, as well as other general requirements.



**309-5.5.2 NON-STREET AREAS**

All excavations not within the street right-of-way may be backfilled with native material. This native backfill shall be earthen, varying in size from clays to gravels, without any stones or lumps larger than two and one-half inches in greatest dimension. The backfill shall be thoroughly compacted by an approved method.

Conduit shall not be covered until inspected and approved by the City Engineer or until the City Engineer has measured the location of junction boxes and conduit.

Trenches shall be backfilled up to the elevation of the top of sidewalk or adjacent finish grade and shall be leveled and smoothed.

**309-5.5.3 NARROW TRENCHES IN EXISTING STREETS**

Excavations in existing pavement which are less than six inches in width shall be backfilled with slurry cement conforming to the provisions of Section 200-8, "Slurry Cement Backfill." Slurry cement backfill shall be placed to within one inch of the existing pavement. Following slurry backfill and until permanent asphalt surfacing is in place, the trench shall be protected by barricades, plates or cutback, as approved by the City Engineer. Prior to final resurfacing, the edges of the pavement shall be coated with paint binder. The permanent pavement shall be placed one-eighth inch above the existing pavement with asphalt concrete, State of California mix design as follows:

| ASPHALT CONCRETE MIX DESIGN |                   |
|-----------------------------|-------------------|
| Aggregate Grading           | Type B, 1/4" Max. |
| Asphalt Binder              | AR-4000           |
| Asphalt Content             | 5.8% to 6.2%      |

Permanent paving shall be completed within 72 hours after initial backfill has taken place. If a neat trim pavement edge has been maintained, no saw cut or extra pavement removal is required.

Where trenches are wider than six inches but less than 18 inches due to the needs of the construction activity or sloughing of the trench or other similar occurrence, the slurry method of backfill as described above for trenches less than six inches wide may be used. The pavement shall be patched in accordance with Standard Drawing No. 201-1, "Trench Details," including the saw cut and additional pavement removal.

**309-6 STREETLIGHT INSTALLATION**

**309-6.1 LOCATION**

Unless otherwise shown on the Plans or required in the Special Provisions, streetlight foundations shall be placed adjoining the back edge of sidewalk. The bolt pattern shall be laid out so that the mast arm is perpendicular to the street centerline, unless otherwise shown on the Plans, or directed by the City Engineer.

### 309-6.2 STANDARD PLANS

All construction and materials shall conform, where appropriate to the following City Standard Plans:

| STANDARD PLANS |                             |
|----------------|-----------------------------|
| Plan No.       | Title                       |
| 301-11         | Location Details for Lights |
| 301-12         | Streetlight Luminaires      |
| 301-13         | Standard Streetlight        |
| 301-14         | Post Top Streetlight        |
| 301-15         | Streetlight Numbers         |

### 309-6.3 FOUNDATIONS

Concrete for use in foundations shall conform to the provisions of Section 20 1-1, "Portland Cement Concrete." All miscellaneous mounting materials, including nuts, bolts, and washers, shall be galvanized in accordance with the provisions of ASTM A153.

Existing conduits, as well as new conduits, shall not penetrate the streetlight foundation. Where such penetration is unavoidable, the City Engineer shall require that the streetlight location be adjusted (moved), or shall require such additional measures as deemed necessary to protect the conduits. Each such penetration requires specific approval on a case-by-case basis.

Foundation bolts and conduit to be set into the concrete shall be suspended and held in place by a template securely fastened to the foundation forms. Foundations shall be poured in 2 lifts, the first lift to extend up to within approximately 6" of the top of finished concrete. The first lift will serve to hold the bolts in place. Nuts, with washers above and below the streetlight base, will be placed on the bolts and poles set upon these nuts. Reinforced (rebar "cages") cast-in-drilled-hole concrete foundations shall cure at least 7 calendar days prior to erecting poles. For lesser foundations, 3 calendar days shall be the minimum.

### 309-6.4 POLES

Poles shall be erected and set in a vertical position. Poles shall be erected after the first lift of concrete has cured as required. All nuts shall be tightened to a snug fit prior to placing the second lift of concrete.

Poles with mast arms shall be erected so that the arm is perpendicular to the street centerline, unless otherwise shown on the Plans, or directed by the City Engineer. The second lift of concrete shall be placed and finished after the pole has been erected.



**309-6.5 LUMINAIRE**

The luminaire for standard streetlights shall be installed on the mast arm in accordance with the manufacturer's recommendation. It shall be installed and adjusted to obtain the required distribution pattern.

The luminaires for post top streetlights shall be installed in accordance with the manufacturer's recommendations. It shall be installed in a true vertical position in the proper orientation to produce the required distribution pattern.

All luminaires shall be installed so as to produce weather-tight connections. The luminaire shall be wired in accordance with the requirements of Section 309-7, "Electrical Wiring."

**309-7 ELECTRICAL WIRING****309-7.1 CONDUITS**

All conductors (wires) shall be installed in conduit. Conduit shall be installed in accordance with the provisions of Section 309-5, "Underground Conduit Installation."

Only one conduit and one set of conductors shall be used to connect to the PG&E service point. The ground or bonding conductor shall terminate in the City pull box immediately adjacent to the PG&E service point.

**309-7.2 CONDUCTOR INSTALLATION**

No conductors shall be drawn into any conduit until the installation run of conduit is complete and inspected. Conduit within a concrete foundation shall have no wires drawn through it until the concrete has set for at least 24 hours. Conductors shall be installed without injury to the insulation. All conductors shall be drawn into the conduit at the same time. The pull-in wire or rope used for drawing conductors into conduit shall not be attached to the copper conductor alone. A cable grip shall be used and applied in such a manner to place tension on both conductor and insulation. A UL listed inert lubricant shall be used.

Cables shall be continuous from luminaire to luminaire, if practicable without splices. Splices, if any, shall be made in pull boxes and the base of light standards.

**309-7.3 CONDUCTOR SUPPORT**

Conductor support shall be provided in all light poles where the distance from the post base to the luminaire exceeds 25' in height. The conductor support shall be attached to the inside wall of the pole or mast arm. It shall be a clamping device constructed of or employing insulating wedges or other suitable insulating support. Where clamping of insulation does not adequately support the cable, the conductor shall also be clamped.



### **309-7.4 CONNECTORS**

Conductors shall be joined by UL listed connectors. Connectors shall be “Scotchlok” by 3M or an approved equal shall be required for splicing all #8 AWG conductors or smaller. Compression type connectors, Thomas and Betts (“T & B”) or approved equal or split-bolt connectors, “FCI-Burndy” or approved equal, shall be used to make up all splices #6 or larger on copper wire. Aluminum wire splices shall be made up by using compression type connectors, “T & B” or approved equal. Aluminum wire shall be coated with “Noalox” or approved equal, prior to splicing.

### **309-7.5 SPLICES**

Splices will only be permitted in pull boxes and the base of light standards. All splices shall be capable of satisfactory operation under continuous submersion in water. 3M “Scotchcast” splice kits or approved equal shall be used to insulate below-ground splices. 3M Scotch Super “88” and “Skotchkote” or approved equal shall be used to insulate above-ground splices.

### **309-7.6 FUSED SPLICE CONNECTOR**

In each light pole, level with the hand hole, a fused disconnect splice connector shall be installed in each ungrounded conductor between the line and the ballast. The connector shall be readily accessible regardless of whether the ballast is remote or is integral with the luminaire. The fuseholder shall be TRON “HEB-AA” by Cooper Bussman (30A, 600V), or approved equal.

For 240-volt circuits each connector shall be designed so that both ungrounded conductors are disconnected simultaneously. The connector shall have no exposed metal parts, except the head of a stainless steel assembly screw may be exposed. The head of the metal assembly screw shall be recessed a minimum of 1/32” below the top of a plastic boss which surrounds the head.

The splice connector shall completely enclose the fuse and shall protect the fuse against damage from water and weather. The contact between the fuse and fuse holder shall be by spring pressure. The terminals of the splice connector shall be rigidly crimped, using a tool of the type recommended by the manufacturer of the fused splice connector, onto the line conductors and the conductors to the ballasts and shall be insulated and made waterproof in accordance with the splice connector manufacturer’s recommendations. Fuses shall be standard midget, fermie type.

### **309-7.7 BONDING AND GROUNDING**

Metallic cable sheaths, box covers, metal conduit, non-metallic conduit grounding wire, ballast and transformer cases, service equipment, sign switches, anchor bolts, and metal poles and pedestals shall be made mechanically and electrically secure to form a continuous system, and shall be effectively grounded. Bonding and grounding jumpers shall be copper braid of the same cross-section area as No. 8 or larger for all systems. Equipment grounding conductor shall be color coded to Code requirements or shall be bare.

Bonding of poles and pedestals shall be by means of a bonding wire or braid attached from a grounding bushing or wire to all anchor bolts, or to a 3/16” (or larger) cadmium plated bolt installed in the lower portion of the pole. The terminal for grounding the pole shall be accessible from the handhole.

Grounding of metal conduit, service equipment and the grounded conductor at service point shall be accomplished as required by the Code and the serving utility. Except where using a driven grounding electrode, the grounding conductor need not be any larger than #6 AWG. For bonding purposes in all non-metallic type conduit, a bare #8 AWG stranded copper wire shall be run continuously in all circuits.

A ground electrode shall be installed in the Pull Box which is immediately adjacent to the Pacific Gas and Electric service point. The ground electrode of non-ferrous materials shall not be less than one-half inch in diameter and eight feet in length. Ground electrodes shall be installed in accordance with the provisions of the Code. The service ground shall be bonded to the ground electrode by use of a ground clamp or exothermic weld. Refer to Standard Drawing No. 301-11 for ground electrode location.

Bonding of metallic conduit in concrete or plastic pull boxes shall be by means of galvanized grounding bushings and bonding jumpers.

### **309-8 TESTING**

Prior to acceptance of the work, the following test shall be made on all lighting circuits, in the presence of the City Engineer.

1. Test for continuity of each circuit.
2. Test for grounds in each circuit. The insulation integrity shall be as specified in Article 110-7 of the National Electrical Code.
3. A functional test in which it is demonstrated that each part of the system functions as specified or intended herein. Streetlights shall be functional for a continuous period of two days. At that point in time, a maintenance period of 90 days shall commence. During the maintenance period, the Contractor shall be responsible for the replacement of any defective components or workmanship.

Any faults in any materials or in any part of the installation revealed by these tests shall be replaced or repaired in a manner approved by the City Engineer at the expense of the Contractor. The same test shall be repeated at the expense of the Contractor until no faults appear.

### **309-9 PG&E SERVICE**

Upon satisfactory completion of testing and all Contract work, the City Engineer will arrange with Pacific Gas and Electric to complete service connections to the streetlights and commence service.





# APPENDIX I

---

City Adaptations to Green Book



| Section | Page   | Detail | Title                  | Sheet | Comments:   |
|---------|--------|--------|------------------------|-------|---|
|         |        |        |                        |       | Add sheet for retrofit/repair, plan view for doweling and 18" AC patch.                       |
|         |        |        |                        |       | Add sheet for heavy curb & gutter at bus stop locations.                                      |
|         | 301-2  |        | Barrier Curbs          | (2)   | Recommend to be used on case-by-case basis. Add vertical #4 rebar dowels.                     |
|         | 301-3  |        | Curb Ramps             | (1-4) | Eliminate / Substitute with Caltrans Std Plan A88A  |
|         |        |        |                        |       | Note: Domes Shall be black unless specified on plan.  |
|         | 301-4  |        | Standard Driveways     |       | Add detail for Historical Driveway  |
|         | 301-5  |        | Monument Box           |       | Revise to meet accepted current industry standards.   |
|         | 301-6  |        | Street Barricade       |       | Add pressure treated wood for rails and posts   |
|         | 301-7  |        | Bike Path Details      |       | Complete Revision. Bollard locations to be determined on a case-by-case basis.                |
|         | 301-8  |        | Bollard Details        | (1-2) | Suggest eliminating sheet 1. See transportation comments.                                     |
|         | 301-13 |        | Standard Street Light  |       | Handhole: Add "Minuim" size to be 2"x4"   |
|         | 301-14 |        | Post Top Street Light  |       | Handhole: Add "Minuim" size to be 2"x4"   |
|         | 301-16 |        | Property Corner Marker |       | Revise to meet accepted current industry standards.   |
|         |        |        |                        |       | Complete Revision: See Landscapiforms "Curved Canopy Style" shelter. (Used on 8th Street CIP) |
|         | 301-17 |        | Bus Stop Shelter       |       |   |

#### **WATER DIVISION**

|             |     |        |                                |       |  |
|-------------|-----|--------|--------------------------------|-------|--|
| 203-4.5 (5) | 82  | N/A    | Locating Wire                  |       | Locating wire insulation color for water mains shall be white or "Blue"  |
|             |     |        |                                |       | Suggest to add wording for continuity testing (See City of Roseville Standards)                                      |
| 203-8.7.1   | 88  | N/A    | Construction Materials         |       | Review wording in section.   |
|             |     |        |                                |       | Add wording: Material other than "Bronze" to be reviewed on a case-by-case basis. Low lead content?                  |
| 305-12      | 132 | N/A    | Disinfection and Flushing      |       | Review wording in section: Is the stated method for disinfection sufficient???                                       |
|             |     |        |                                |       | Add wording: Temporary RP to be tested above ground per Std Plan Detail 101-11                                       |
|             |     | 101-12 | Sacrificial Anode Installation | (1-2) | Redraft Detail. Prefer to have anode not in paved driveway area. Tracer wire clamped directly below angle meter stop |
|             |     |        |                                |       | and accessible from inside meter box.  |
|             |     | 101-9  | Backflow Assembly              | (1-2) | Redraft Detail to show tracer wire .   |

#### **WASTEWATER AND STORMWATER DIVISION**

|          |     |     |                         |  |   |
|----------|-----|-----|-------------------------|--|---|
| 203-2.4  | 77  | N/A | PVC Storm Drain Pipe    |  | Allow use of PVC in road/street right-of-way???   |
| 306-13.2 | 140 | N/A | Video Inspection        |  | Item discussed. Video inspection of main prior to any construction work on line??   |
| 306-14   | 141 | N/A | Abandonment of Services |  | Item 2. Substitute plug at both ends with plug at back-of-walk.   |
|          |     |     |                         |  | Rear Yard Main: Add wording that services to be abandon shall be plugged at the main and inspected by the city prior to backfill. |



**Section Page Detail Title Sheet Comments:**

**TRANSPORTATION DIVISION**

|         |        |                         |     |   |
|---------|--------|-------------------------|-----|---|
|         | 301-8  | Bollard Details         |     | Redraft sheet 2 with metal sleeve and padlock /hinged lid.? (Hugh has the sample)   |
|         | 301-9  | Traffic Signing Details | (2) | (Square Post) Redraft Sheet 2 per markups.  |
|         |        |                         |     | Create new sheet for new street name sign detail/dimensions. See markup.  |
|         | 301-10 | Private Street Sign     |     | Add (Square Post) as an option.   |
| 205-3   | 93     | Traffic Signs           |     | Recommmed to review wording in section. Add material spec for metal (Square Posts)  |
| 205-3.3 | 93     | Wood Posts              |     | Recommend to delete. No longer city standard but used for tempoary construction sign posts.   |
| 308-2   | 155    | Traffic Signs           |     | Recommmed to review wording in section and include street name signs aswell.  |
| 308-2.3 | 155    | Post Installation       |     | Recommend to add wording to include compation of subgrade for those posts installed in planter areas. Example 2nd Street CIP Bulbouts |

**ELECTRICAL DIVISION**

|       |        |                                 |  |  |
|-------|--------|---------------------------------|--|--|
| 206-2 | 95     | High Pressure Sodium Luminaires |  | Eliminate specification for high pressure sodium fixtures (HPS).                                     |
|       |        |                                 |  | All new fixtures will be LED or other type.  |
|       |        |                                 |  | Mast-arm mounted streetlights shall be Beta, Leotek, Cooper, or submitted approved equal.            |
|       |        |                                 |  | Post top fixtures shall be Hadco or submitted approved equal.  |
| 206-3 | 95     | Poles                           |  | Need language describing decorative poles - See Butch  |
|       |        |                                 |  |  |
|       | 301-12 | Street Light Luminaires         |  | POST TOP LUMINAIRES: Shall be Hadco or submitted approved equal. Delete "WATTS" & "BALLAST" columns. |
|       |        |                                 |  | COBRA HEAD LUMINAIRES: Shall be LED . Approved manufacture shall be Beta, Cooper, Lectek or Equal.   |
|       |        |                                 |  | Delete "WATTS" & "BALLAST" columns.  |

## APPENDIX J

---

FSE Public Education Outreach Materials

*Consider supporting the restaurant service providers that maintain a “Green Business Certificate” with the City. This certificate recognizes the service providers that perform environmentally friendly and responsible cleaning practices*

***THE CITY OF DAVIS***  
***Best Management Practices,***  
***Cost Saving Measures,***  
***Practical tips,***  
***for***  
***Food Service***  
***Establishments***

*Support a Green Business & Support a Local Business*

Public Works Office 757-5686  
Restaurant  
Program 757-5625

*If possible, use a local business or a business licensed with the City of Davis. Locate those providers on the “Restaurant Service Provider list” or the City’s website of local businesses.*



|   |
|---|
| <h2>Storm water</h2>  |
| <p><b>Facts</b></p> <p>The City's Storm drain system is for the conveyance of rainfall only. The City has a permit to discharge Stormwater, and is regulated by the State of California for our Stormwater discharges.</p> <p><b>Best Practice</b></p> <p><b>P</b>our mop water into a mop closet, utility sink or curbed floor drain. Do not pour it onto a parking lot, in an alley, on a sidewalk or into the gutters.</p> <p><b>K</b>eep the area around outdoor trash bins litter free, trash, used food containers. This is a Health Code requirement and customers or employees are more likely to use them when they are kept clean</p> <p><b>D</b>o not put liquids in your dumpster or rinse it out – if needed request a change.</p> <p><b>K</b>eep dumpster lids closed to prevent rain from entering and it reduces pests/vermin. Bins should be water tight</p> <p><b>C</b>lean liquid spills promptly around tallow bins and dumpsters. Use absorbent material for liquid waste do not rinse area.</p> <p><b>H</b>igh pressure washing of parking lots must be contained, recaptured and disposed of into the sewer system. Check the BASMAA website for the correct procedures. Washing of shopping carts, food baskets etc must also be disposed of to the sewer system.</p> <p><b>O</b>utside eating areas must be sweep up / picked up first, then rinsing with water only is permitted.</p> |

|   |
|---|
| <h2>Grease Trap or Interceptor</h2>   |
| <p><b>Facts</b></p> <p>A grease Interceptor is greater than 500 gallons in size and are usually located in-ground outside a building.</p> <p>A grease Trap is smaller, and usually located under a counter and require more maintenance than an Interceptor does. A dishwasher may discharge into an Interceptor. A dishwasher may not discharge into a Trap.</p> <p>Traps must be kept accessible for maintenance, inspection and cleaning at all times. Traps need to be sized appropriately. Smaller traps will clog quickly and pass grease into the buildings pipes or sewers.</p> <p><b>Best Practice</b></p> <p><b>C</b>heck or clean a grease <u>Trap</u> once a week.</p> <p><b>C</b>heck or clean an <u>Interceptor</u> every other month.</p> <p><u>Trap or Interceptor</u> cleaning is required when they have accumulated floatable or settleable material accounting for 25% of its wetted volume.</p> <p><b>W</b>ater temperatures over 140 F will dissolve grease.</p> <p><b>U</b>se cooler water temperatures in prewash sinks.</p> <p><b>D</b>o not use a <u>Interceptor or Trap</u> to dispose of grease/oil, use your rendering bin.</p> <p><b>O</b>bserve/check the cleaning of your interceptor to insure a thorough job is being done. Insure during the cleaning process, influent/effluent tees have not been damaged.</p> <p><b>G</b>rease <u>Trap</u> cleaning can be performed by staff, eliminating outside contractor costs. Frequent cleaning eliminates odors and clogging of building pipes.</p> <p><b>G</b>rease removed from a <u>Trap</u> may be recyclable, check with your grease recycler/rendering listed on the "Restaurant Service Providers" list.</p> <p><b>W</b>hen routinely performed, cleaning will greatly reduce the discharge of fats, oil and grease into the sewer system and keep odors down from traps/interceptors.</p> <p><b>U</b>se a licensed company for interceptor cleanout and disposal.</p> <p><b>D</b>ry scrap all plates, utensil, pots and pans before washing.</p> <p><b>Do Not</b></p> <p><b>D</b>o not add surfactants, dispersants, degreaser, biological agents into your grease <u>Trap or Interceptors</u>.</p> |

|   |
|---|
| <h2>Kitchen Exhaust Systems</h2>  |
| <p><b>Facts</b></p> <p>Kitchen exhaust fans are required to be cleaned periodically by the Uniform Fire Codes. Cleaning includes the interior and exterior housing and grease collection tray.</p> <p><b>Best Practice</b></p> <p><b>K</b>itchen exhaust cleaning contractors should be trained and have available current training certificates available.</p> <p><b>R</b>oof exhaust vents should not be cleaned or rinsed to the roof surface, building gutters or the City's storm drain system. Verify your vent contractor captures all waste associated with cleaning the exhaust system.</p> <p><b>G</b>rease collection trays need to be checked regularly, and staff can clean them, eliminating outside contractor costs. Trays must be covered.</p> <p><b>R</b>egular routine cleaning of the inside grills by restaurant staff will help keep the ducts cleaner, and reduce the need for outside cleaning contractors.</p> <p><b>Do Not</b></p> <p><b>D</b>o not clean exhaust grills outside.</p> <p><b>D</b>o not rinse roof exhaust cleaning waste to the building gutters.</p> |

|  |
|--|
| <h2>Kitchen Mats</h2>  |
| <p><b>Best Practice</b></p> <p><b>C</b>lean/wash kitchen mats in a mop closet, utility sink. It is in violation of Health Codes to wash mats in food preparation sinks.</p> <p><b>T</b>o ease cleaning, consider replacing and using smaller sized mats.</p> <p><b>C</b>onsider washing mats at a coin operated wash.</p> <p><b>Do Not</b></p> <p><b>D</b>o not wash, clean, rinse kitchen mats outside.</p> |

|  |
|--|
| <h2>Surface Cleaning</h2>  |
| <p><b>Facts</b></p> <p>Surface cleaning rinse everyday dirt/grime from building surfaces. Surface cleaning keeps outside eating areas clean and sanitary.</p> <p><b>Best Practice</b></p> <p>Follow the procedures outline at the BASMMA website for surface cleaning.</p> <p><b>Do Not</b></p> <p><b>D</b>o not use any soap, cleaners, sanitizers for outside cleaning and disposal to the storm drain system.</p> |

# Best Management Practices for Food Service Establishments

City of Davis  
Department of Public Works  
June 2011





## INTRODUCTION

---

The City of Davis Public Works Department (PW) is responsible for developing, implementing and reporting on the status of three State mandated regulatory programs aimed at reducing pollutants discharged into our sanitary sewer and our storm water collection systems.

The requirements of these programs are contained within the State Water Resources Control Board Order NO # 2006-0003-DWQ for wastewater collection agencies, the City's Phase II General Stormwater Permit CA 00004, and the City's NPDES Permit CA 0079049 issued to the Wastewater Treatment Plant.

The above regulatory programs all contain the general conditions to be implemented, and specific targeted pollutants for reduction or control. The City is required by law to address the targeted pollutants through established measures. These measures may be prohibiting discharges, numerical limits, and source control programs or establishing Best Management Practices (BMP).

Order NO # 2006-0003-DWQ requires the City to implement measures to reduce the discharges of Fats, Oils and Grease (FOG) into the sanitary sewer. Reduction of FOG discharges requires a grease removal device (GRD) and periodic checking of the GRD. A GRD is used to remove FOG from a food service establishment (FSE) discharges to the sanitary sewer. GRDs may be an in ground gravity interceptor or the smaller grease trap usually located above ground.

PW has established written BMP's specifically for FSEs, and businesses that use a GRD (i.e. bakeries, car washes, pressure washing).

BMP's for an FSE were implemented to address the slowdowns, blockages and sanitary sewer overflows caused by FOG discharged into our collection system. The waste discharge requirements contain the regulations require Cities to develop and implement source control measure for FOG within their service area.

Implementing the BMPs is a source control measure will address overflows, slowdowns blockages attributable to FOG, and reduce the City's sewer maintenance costs attributable to FOG that is discharged by FSEs.

BMPs have established the frequency required for checking and cleaning these devices. BMP's also provide guidance for businesses and FSE in reducing discharges stormwater collection system.

BMPs are for the protection of the collection system, reducing City's sewer maintenance costs and providing environmental sound and economically responsible sewer service in our service area.

## Kitchen exhaust Fan

*BMP*

*background*

Food service establishments must adhere to the cleaning frequency for kitchen exhaust hoods as outlined in the NFPA Table 11.3

| <u>Type or Volume of Cooking</u> -----   | <u>Frequency</u>    |
|--|---------------------|
| Systems serving solid fuel cooking operations-----   | <b>Monthly</b>      |
| Systems serving high-volume cooking operations-----<br>such as 24-hour cooking, charbroiling, or wok cooking.              | <b>Quarterly</b>    |
| Systems serving moderate-volume cooking-----<br>operations.  | <b>Semiannually</b> |
| Systems serving low-volume cooking operations-----<br>such as churches, day camps, seasonal businesses, or senior centers. | <b>Annually</b>     |

*Kitchen exhaust hoods require periodic cleaning. Requirement are identified in the National Fire Protection Association, (NFPA) 96 Fire Codes Table 11.3 (see left) Public Works follows the cleaning frequency as specified in table 11.3 of the NFPA 96 codes.*

*Cleaning may be specified as monthly, quarterly, semi annually or annual cleaning depending on the type of cooking.*

During the exterior cleaning process, any discharge of cleaning solution, rinse water or material to the roof surface or building gutters is prohibited.

*A collection system for the cleaning water and trained personnel must be used to prevent the accidental discharge or leaking of cleaning solutions from this procedure to the buildings roof or gutters.*

In between the required kitchen exhaust fan cleaning, the roof grease collection trays must be checked to ensure they do not overflow.

Grease collection tray must be securely attached to the fan housing, covered and have a spout directing collected grease/oil into the covered collection tray.

*Grease collection trays are used to collect fugitive grease/oil discharge from the kitchen exhaust fan. Grease tray must be securely attached to the fan housing, covered to protect from the weather and have a downspout directing the material into the collection container.*

Contractors used for kitchen exhaust hood cleaning must be trained and have current certificates of training for exhaust hood cleaning.

*Copies of Training Certificates should be available upon request.*

The contractors invoice used for cleaning kitchen exhaust hoods, must note that the exterior grease collection tray was cleaned, securely fastened, covered to prevent rainfall intrusion and has a downspout present for routing fugitive grease into the grease collection tray.

*Roof grease collection trays must also be cleaned at the time of the hood cleaning and checked periodically.*

Contractors must maintain a current City of Davis business license and provide a copy with their cleaning invoice. Contractors must provide copy of their current, valid training certificate specializing kitchen exhaust cleaning

*Receipts from cleaning must be available upon request.*

Maintain records of cleaning/maintenance 3 years.

## GREASE BOX INSTALLATION

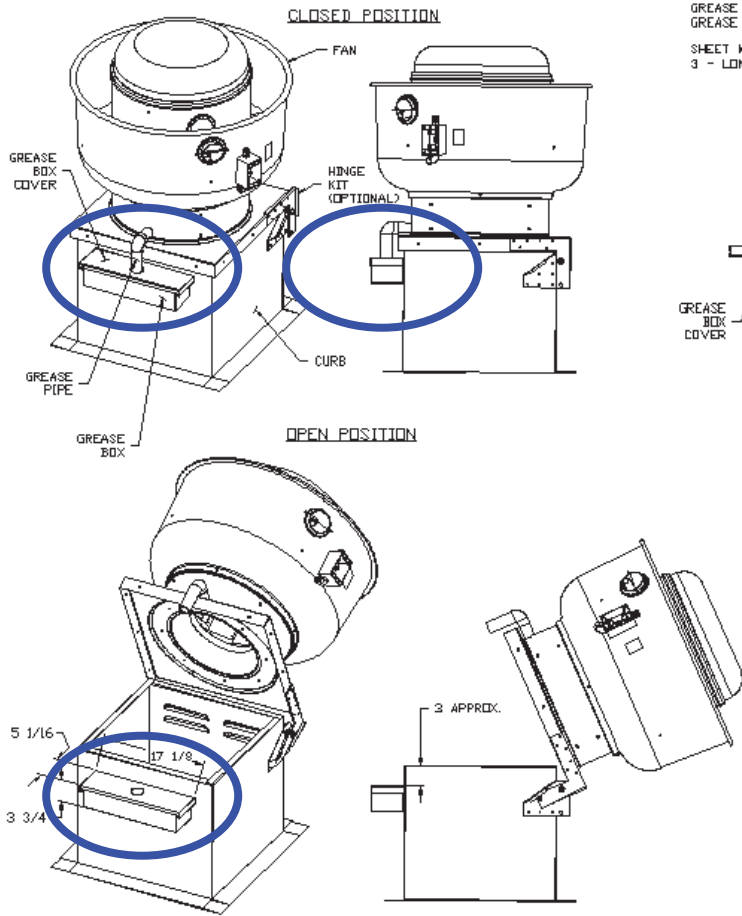

### PARTS INCLUDED

- GREASE BOX
- GREASE BOX COVER
- GREASE PIPE
- SHEET METAL SCREWS  
3 - LONG (3/4" LG)

### GREASE BOX FIELD INSTALLATION

#### STEP 1)

ATTACH GREASE BOX COVER TO THE CURB, HOLD 3" DIMENSION AS SHOWN ON PIC. 1. SCREW GREASE BOX COVER TO CURB USING (3) LONG (3/4" LG) SCREWS AS SHOWN ON PIC. 2.

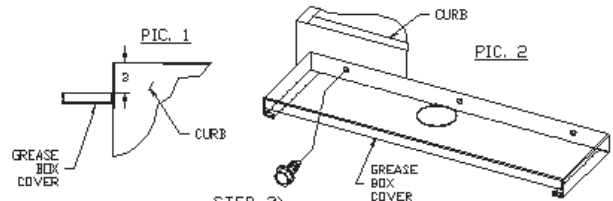

#### STEP 2)

ATTACH GREASE BOX TO GREASE BOX COVER, SLIDE AND DROP, AS SHOWN ON PIC. 3.

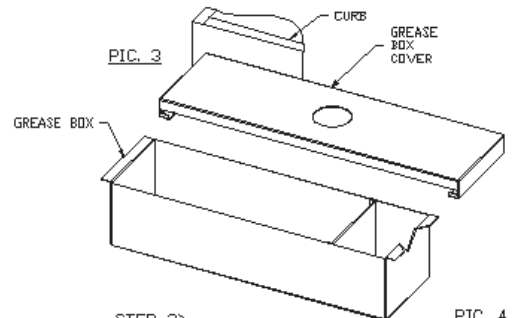

#### STEP 3)

INSTALL GREASE PIPE AS SHOWN ON PIC. 4.

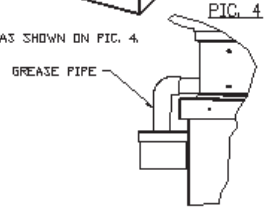

Example of one style of a grease collection tray on a kitchen exhaust fan.





## Grease Trap maintenance

(Example cross-section & images below)

*BMP*

*background*

---

### GREASE TRAP

Grease traps must remain readily accessible for checking, cleaning or maintenance at all times.

*Cleaning and checking should be easy to accomplish and will be more readily done if trap is accessible. Complete and frequent cleaning will keep down odors from trap. Trap must not have material, kitchen utensils, soap containers etc on or blocking easy and frequent access for cleaning or checking the device in any manner.*

---

At a minimum, any size of grease Trap must be checked weekly.

*This reduces amount of grease entering the drain and protects sewers from grease blockages and overflows. Prevent City of Davis sewer use violations for improperly maintained Grease traps are smaller than interceptors and require frequent servicing. You may train staff to clean a trap and save the cost of a private contractor. City staff will demonstrate the correct method for cleaning traps.*

---

Any chemical/bacteriological additives to a grease interceptor are prohibited

*Emulsifiers, degreasers, bio-additives or solvents will cause grease to be carried through the trap into the building laterals or sanitary sewer where it will re-solidify and may cause blockages, slowdowns or overflows.*

---

Dishwashers/garbage disposal may not be discharged into a grease Trap.

*Dishwasher water temperature will dissolve and emulsify grease in a trap and wash out into the buildings laterals. Material from a garbage disposal will quickly fill a grease trap reducing efficiency.*

---

Establish a log of checking the trap and maintain records of cleaning/maintenance for 3 years.

*Required by City Sewer use ordinances*

---

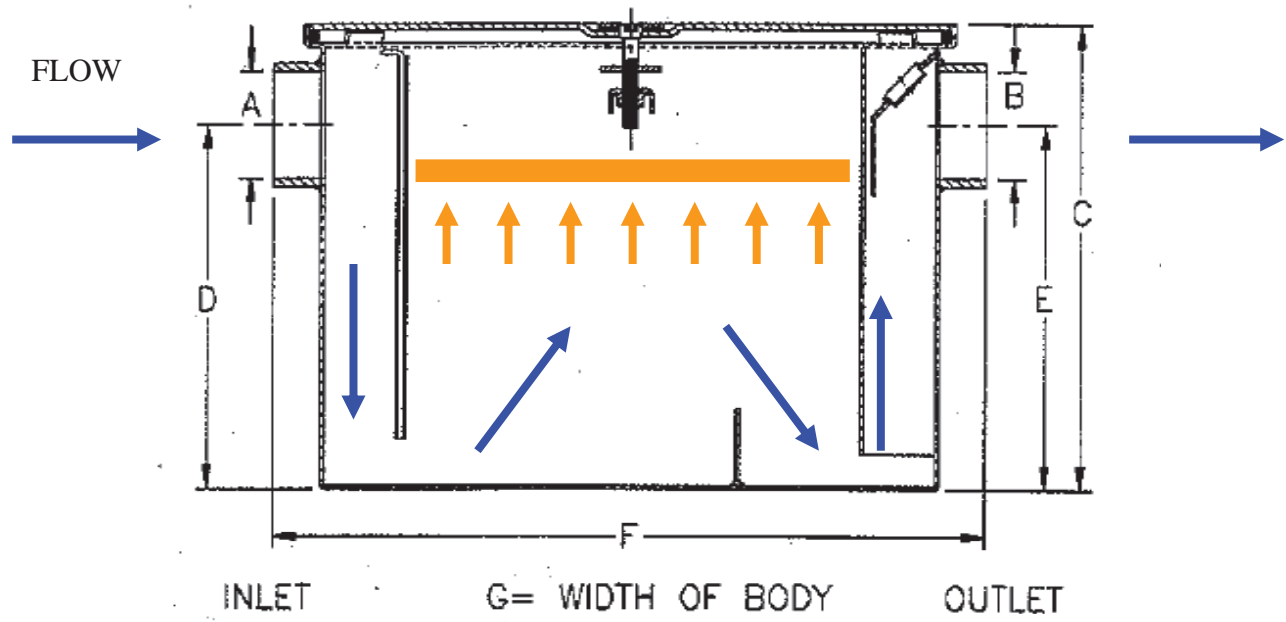

*Example of a under counter style grease trap.*



## Grease Interceptor maintenance

(Example diagram below )

---

*BMP*

*background*

---

### GREASE INTERCEPTOR

At a minimum, grease interceptors must be checked monthly. City staff can assist in determining the frequency of cleaning needed in order to minimize the cost associated with cleaning the in-ground interceptors.

*Inspect cleaning to ensure a complete job has been done by the contractor.*

Interceptor cleaning is required before it reaches 25% of its hydraulic capacity in the 1<sup>st</sup> stage from the accumulated grease/sludge.

---

Influent and effluent tees must be checked at each cleaning and noted as intact on the vendor's invoice.

*Cleaning contractor must indicate where they disposed of the material on the invoice*

---

Any chemical/bacteriological additives to a grease interceptor are prohibited.

*Do not use emulsifiers, degreasers, bio-additives or solvents in interceptors. Use of these agent cause grease to be carried into the sewer lines where it will solidify.*

---

Use companies that maintain a current City of Davis business license.

*Required by City municipal codes*

---

Establish a log of checking the interceptor and maintain records of cleaning/maintenance for 3 years.

*Required by City Sewer use ordinances*

---



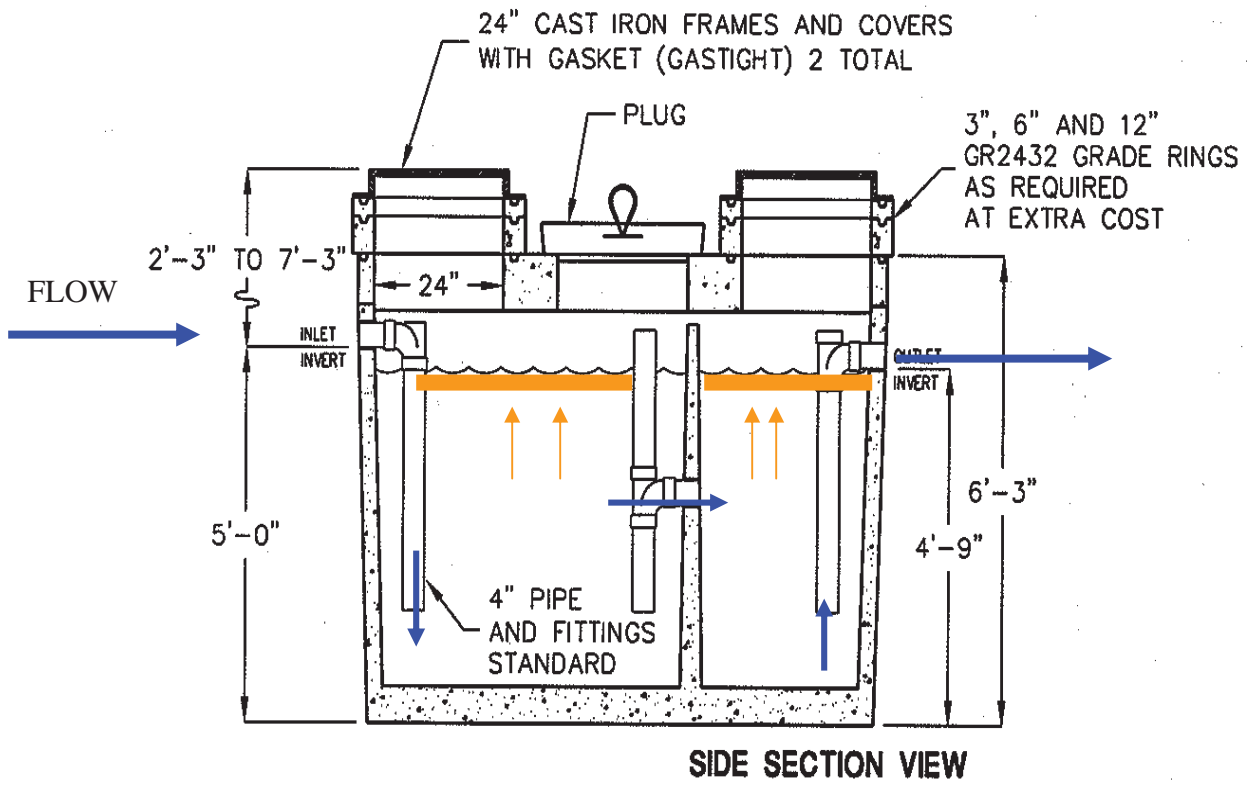

OPERATING CAPACITY: 1,000 GALLONS.



## Trash enclosures

*BMP*

*background*

“Article 4, California Retail Food Code July 20, 2007

114245.1.

**a)**-All refuse, recyclables, and returnable shall be kept in nonabsorbent, durable, cleanable, leak proof and rodent proof containers and shall be contained to minimize odor and insect development by covering with close-fitting lids or placement in a disposable bag that is impervious to moisture and then sealed.

**d)**-Storage areas, enclosures, and receptacles for refuse, recyclables, and returnable shall be maintained in good repair.

**e)**-Refuse, recyclables, and returnable shall be removed from the premises at a frequency that will minimize the development of objectionable odors and other conditions that attract or harbor insects and roaches.”

*Public Works adopts the current established California Retail Food Codes June 2007-114245.1 section a), d), e) for trash enclosures cleanliness.*

Pressure washing/rinsing of the trash enclosure or trash containers and discharging to the storm drain system is prohibited.

*Dry sweep and mop enclosure as necessary. Wipe down outside of container by hand.*

*Train staff to exercise care when disposing of material in trash container to prevent spills or drips in, on or around trash container.*

*Prevention of odors, vermin, insect, roach habitat. Prevent of visual distraction of customers.*

Container lids must be tight fitting and remain operational at all times. Do not fill containers to the point where the lids will not close.

*Call Davis Waste Removal company for replacement or repair if damaged. 756-4646*

Outside trash container must be watertight and leak proof.

*Liquid waste cannot be disposed of into trash containers.*

## Exterior surface cleaning

*BMP*

*background*

Soap free & chemical free wash-water from sidewalk and Plaza cleaning may be discharged to the storm drain system provided the area(s) has been pre-swept and is free from visible significant pollutants.

Soap free wash-water from exterior building washing or seating free from loose paint, may be discharged to the storm drain system when disposal to landscaping is not available.

Contractors / staff used for surface cleaning must be trained and have current certificates of training for surface cleaning (example below). Training is available on-line from BASMAA website.

Use only contractors that maintain a current City of Davis business license.

*These exceptions are only available when discharges would not violate water quality standards and landscape disposal is not available.*

*Copies of Training Certificates should be available upon request.*

*A 30-minute online pollution prevention training for surface cleaners is available at <http://www.basmaa.org/>*

*Discharge should not wash material existing in gutter system into the storm drain inlets.*



Bay Area  
Stormwater Management  
Agencies Association

### CERTIFICATE OF TRAINING

**Kirk Freeman**

a **Recognized Surface Cleaner**

agrees to follow, to the greatest practical extent, pollution prevention practices including techniques for proper cleaning and wash water disposal, as described in the BASMAA surface cleaners training program.

**Training date: 4/7/2010**

**Training certificate expires: 4/7/2011**

**Training certificate number: 597**

  
Dale Bower  
Urban Runoff Program  
Manager, CRWQCB San  
Francisco Bay Region

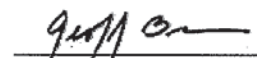

  
Geoff Brosseau  
Executive Director, Bay Area  
Stormwater Management  
Agencies Association



## Kitchen mats

| <i>BMP</i>  | <i>background</i>  |
|---|--|
| <p>Kitchen mats may not be cleaned or rinsed outside where waters will discharge to the surface pavement, sidewalks, storm drains, streets, parking areas or gutters. Mats should be wash/cleaned at a mop closet, utility sink or possibly a coin operated wash.</p> | <p><i>Prevent storm water violations with the City of Davis.</i></p> <p><i>It is a violation of State Health Codes to wash any mat in any food preparation sink.</i></p> |

## Kitchen Practices

| <i>BMP</i>  | <i>background</i>   |
|---|---|
| <p>Use water temperatures less than 140<sup>0</sup>F for washing kitchen utensil in sinks/ triple sinks.</p>  | <p><i>Temperatures above 140<sup>0</sup> will dissolve grease. Grease may then cool and solidify in the building lateral or in the sewer system..</i></p>   |
| <p>Dry scrape/wipe cooking utensil, plates, food containers first, then pre-rinse and clean.</p>  | <p><i>“Dry scrape/wiping” will reduce the grease loading and solids material being discharged into a grease removal device and the sewer system.</i></p>  |
| <p>Dispose of spent greases, oils or meat drippings in a covered rendering bin.</p>   | <p><i>Pressure washing of rendering container and discharging to the storm drain system is prohibited.</i></p> <p><i>Use absorbent, dry sweep and mop as necessary. If needed, wipe down outside of container by hand.</i></p> <p><i>Reduce cleaning requirements and potential cleanup Orders by properly training staff to exercise care when disposing of material in container to prevent spills or drips in, on or around rendering container.</i></p> |
| <p>Maintain an accessible spill kit(s) for oils/liquids at strategic locations within the kitchen area.</p>   | <p><i>Use a dry cleanup method such as cat litter or paper towels to pick up oil and grease spills before mopping.</i></p>  |
| <p>Fine mesh drain screens shall be used in all floor sinks receiving indirect waste from sinks, triple sinks, prep sinks mop sinks, or the like and capable of trapping particle greater than 1/16<sup>th</sup> of an inch in any direction.</p> | <p><i>Screens trap particles of food waste to prevent discharging to the building sewer laterals. Screens are available at most restaurant supply stores.</i></p>   |

## Definitions

---

**Best Management Practices (BMPs)** – Practices that will help to reduce the quantity of fats, oil and grease discharged to grease removal devices from food handling operations.

**Sanitary sewer** – The sewer owned and operated by the City.

**Fats, Oil, and Grease (FOG)** – Fats, oil and grease generated from food preparation, food service, and kitchen clean up. Most types of restaurant and food service establishment generate FOG.

**Food Service Establishment (FSE)** – Includes but is not limited to any facility preparing and/or serving food for commercial use or sale. This includes restaurants, cafes, lunch counters, cafeterias, hotels, hospitals, convalescent homes, factory or school kitchens, catering kitchens, bakeries, grocery stores with food preparation and packaging.

**Grease removal device (GRD)** – a generic term for a grease interceptor, grease trap.

**Grease interceptor** – A large, partitioned vault made of various materials, installed to remove grease and food waste by trapping floatable and settleable solids so that they can be separated and removed before discharge to the community sewer. It is usually installed underground, outside of the establishment.

**Grease trap** – A device designed to retain grease before it enters sewer/building laterals. It is usually installed indoors in kitchen floors or under counters.

**Permit Holder** – Owner or operator of the food service establishment were the Pollution Prevention Permit was issued.

**Public Works Department** – A department within the City that is responsible for maintenance, operation and repair of the all public utilities with the City's limits.

**Service Area** – Area served by City's sanitary sewer.

| BMP's  | REASON FOR   | BENEFITS   |
|--|--|--|
| Train all staff on BMPs  | People are more willing to support an effort if they understand its basis  | Trained staff will be more likely to implement BMPs and work to reduce grease discharges to the sewer.                                   |
| Post "No Grease" signs above sinks and on the front of dishwashers.  | Signs serve as a constant reminder for staff working in kitchens.  | Reminders help minimize grease discharge to the sewer or grease removal device.  |
| Check grease interceptor solids depth routinely. The combined thickness of the floating grease and the bottom solids should not be more than 25% of the total interceptor depth. | Grease interceptor will not meet performance standards when solids and floating grease levels exceed 25%   | This will keep grease interceptor working at peak performance.   |
| Collect and recycle waste cooking oil.   | These actions reduce grease loading on grease removal devices and the sewer.   | This will reduce cleaning frequency and maintenance costs for grease removal devices and reduce the amount of grease entering the drain. |
| "Dry wipe" pots, pans, and kitchen equipment, before cleaning.   | "Dry wiping" will reduce the grease loading on grease removal devices and the sewer.   | This will reduce cleaning frequency and maintenance costs for grease removal devices and reduce the amount of grease entering the drain. |
| Maintain a routine grease trap cleaning schedule.  | If grease traps are not routinely cleaned, they do not work properly and do not prevent grease from entering the sewer. If the grease trap is not providing adequate protection, a grease interceptor may be required. | This reduces amount of grease entering the drain and protects sewers from grease blockages and overflows.                                |
| Use absorbent paper under fryer baskets.   | This reduces the amount of grease during cleanup.  | This reduces amount of grease entering the drain and protects sewers from grease blockages and overflows.                                |
| Use absorbents such as cat litter or paper towels to pick up oil and grease spills before mopping.   | Decreases the amount of grease that will be put down the drain.  | This reduces amount of grease entering the drain and protects sewers from grease blockages and overflows.                                |
| Do not use emulsifiers or solvents other than typical dishwashing detergents.  | Emulsifiers and solvents will break down grease causing a problem in the sewer downstream.   | Allows for proper removal of grease.   |





# **Food Service Establishments**

---

**Best Management Practice**

*Highlights Only*

---

## **In-ground grease interceptors**

---

**Check interceptor every 3 months. If greater than 25 % full, interceptor needs cleaning.**

**Check your interceptor after cleaning for the thoroughness of your cleaning service.**

**Public Works will provide assistance for checking or to determine if cleaning is needed call 757-5686 to schedule a time.**

---

## **Under-counter grease traps**

**Establish an initial daily or weekly internal check to gauge grease accumulation.**

**Determining the frequency for cleaning. Daily once a week etc.**

**If greater than 25 % full of grease, trap needs cleaning.**

**Dispose of the removed material properly.**

**Public Works staff will demonstrate cleaning and checking procedures for you, please call 757-5686 to schedule a demonstration.**

---

## **Kitchen mats**

**Kitchen mats must be cleaned/rinsed at a utility sink, mop closet, car wash etc.**

**It is never permissible to wash outside, at sidewalks, in the parking lot, back door or at the trash enclosures etc.**

---

## **Kitchen exhaust hoods**

**Follow current Fire Codes for hood cleaning frequency.**

**Periodically check grease collection tray on the exterior exhaust hood for fullness.**

**Check your exhaust hood after cleaning for thoroughness of the service.**

**Public Works staff will demonstrate grease tray checking procedures, please call 757-5686 to schedule a demonstration.**

---

## **Trash enclosures**

**Do not dispose of any liquids in the trash container(s).**

**Trash containers must be covered when not in use.**

**Train employees to exercise care when they are disposing of refuse to prevent spills etc**

**It is not permissible to power wash trash container or trash enclosure, only dry sweep, mop and/or wipe down exterior surfaces.**

**Damaged containers may be replaced by calling Davis Waste Removal @ 756-4646.**

---



# **FOOD SERVICE ESTABLISHMENT**

---

## **How to maintain a under-counter grease trap**

*City of Davis  
Public Works Department*



## Background

---

Maintenance staff or other employees of the food service establishment (FSE) may perform grease trap cleaning. The City *does not* require you to use an outside contractor to provide this service.

At a minimum, an FSE must clean/check their trap weekly, or sometimes even daily depending on the size and load to the trap. At no time may the trap be more than 25% full of grease, oil and /or solids. When performed properly and at the appropriate frequency, grease trap maintenance can greatly reduce the discharge of fats, oil and grease to the building lateral and the City's wastewater collection system. Frequent cleaning will also reduce the odor associated with these devices. Use of chemical/biological additives in the trap is prohibited, as is the use hot water, acids, solvents, caustics or emulsifying agents to help keep the trap clean.

## Maintenance Instructions

---

Prepare ahead, a little preparation will save you time and an extra mess to clean up.

1. Spread multiple layers of newspaper on the floor next to the trap to place a plastic bucket on. The paper will catch drips/spills. In addition, protect another area with newspaper where you plan to place and clean the grease trap lid and the internal baffle(s).
2. Locate your plastic gloves, a scoop for grease removal, a putty knife or scraper for the sides and a container to scope the water.
3. Open a medium to heavy weight plastic bag and place it inside a 5-gallon plastic bucket. Drape the excess plastic bag over the sides. Place some type of absorbent material in the bottom of the bucket, inside the plastic bag. The material will absorb the oil/grease/water mixture when you remove it from the trap.

\* Liquid material is prohibited from being disposed of in the trash containers.

## Cleaning

1. Most material will float and congeal on the surface, or it will settle to the bottom of the trap. Clean the floating surface material first, and then remove any built up grease on the side(s) of the trap.
2. Bail out remaining water in the trap to facilitate cleaning the bottom and submerged sides. The "water removed" may be held in another container and discharge back to the system once the trap has been cleaned. Alternatively, water may be absorbed with sufficient amounts of absorbent (i.e. kitty litter) and disposed of in the trash container with the grease. Some of the grease removed may be recyclable, check with your rendering service to verify. (remember liquid material is prohibited from being disposed of in the trash containers)
3. Observe how the interior baffles are orientated and how they can be replaced, this will ensure the baffles will be replaced in the same manner.
4. Remove the baffles if possible.
5. Clean the inside of the trap and its components. Scrap sides, the bottom, the influent and effluent pipes as necessary to remove. Dispose of this material to the 5-gallon bucket with the other congealed surface grease mixture.
6. Clean interior baffles, the trap lid and any parts that you removed.
7. Clean the exterior of the trap and the surrounding area. Check the lid gasket. Replace or repair as necessary. A clean exterior will make it more inviting to routinely service the trap for you / staff next time.
8. Replace interior baffles; inspect to ensure re-assemble is correct. Replace lid and secure.
9. Pickup newspaper and place in plastic bag. Seal and carry to the trash container in the bucket and dispose off.
10. Clean dedicated tools, store scraper, putty knife, absorbent material and paper in dedicated 5-gallon bucket for use next time.
11. Record maintenance date.



# **FOOD SERVICE ESTABLISHMENTS**

---

## **Frequently asked questions**

*City of Davis  
Public Works Department*

## Frequently Asked Questions

---

### **How often must I clean/check my grease trap or interceptor?**

Your under-counter grease trap should be checked weekly to establish a frequency of cleaning needed for your cooking type and customer load. Grease traps must never be more than 25% full of congealed grease, oil or sludge material. Your in-ground interceptor should be checked monthly to determine the cleaning frequency needed. As with traps, your interceptor can never be more than 25% full for grease, oil or sludge in any stages. City staff can assist you in determining the frequency needed.

### **Can I apply for a variance for my grease interceptor/trap cleaning/pumping frequency?**

The City does not have a variance for cleaning. The City allows the individual food service establishment to set their cleaning scheduled based on their individual use, cooking type and customer loading. In any case traps/interceptors can never be more than 25% full of grease, oil sludge in any of its stages.

If requested, City staff will demonstrate how to clean a under-counter trap which would save your restaurant the cost of an outside contractor.

### **How often will my facility be reviewed?**

1 or 2 times per year or as often as necessary to ensure proper maintenance is being applied to all grease pretreatment systems, exhaust fan grease collection tray(s), mat cleaning process, trash enclosures and kitchen BMP practices. You may or may not be informed ahead of time when a review is scheduled.

### **What will the inspector look for and do?**

The inspector will open and inspect the grease trap or interceptor and may request to see all records pertaining to the maintenance and repair of the device. He will ask questions to ascertain whether procedures outlined in the “Best Management Practices” manual have been implemented. City staff will look at the kitchen exhaust fan on the roof and trash enclosure. Any findings from the review will be noted by the inspector and you will receive a written notice of the findings and the required corrective actions, if any.

### **What records do I need to keep?**

Receipts/dates your trap/interceptor was cleaned, dates of exhaust hood cleaning.

### **How do I get help**

Call Public Works front counter at 757-5686 and staff will direct your call.

### **What will this cost me?**

The City does not charge for these services as long as BMPs are followed corrections are completed as agreed on.

### **How long do I have to make corrections?**

Staff will allow ample time to complete corrections.



## APPENDIX K

---

### Sewer System Capital Improvement Program Budget and Schedule

## APPENDIX L

---

### Overflow Emergency Response Plan

# City of Davis

## Overflow Emergency Response Plan



Effective Date: \_\_\_\_\_

Revised Date: \_\_\_\_\_

Approved by: \_\_\_\_\_

Signature: \_\_\_\_\_

Date: \_\_\_\_\_

City Council Adoption Date: \_\_\_\_\_



**Table of Contents**

**Sanitary Sewer Overflow Emergency Response Plan**

(ref. SWRCB Order No. 2006-0003-DWQ Element VI)

1. Purpose
2. Policy
3. Goals
4. Sanitary Sewer Overflow (SSO) Detection and Notification
5. SSO Response Procedures
6. Recovery and Cleanup
7. Water Quality
8. Sewer Backup Into/Onto Private Property Claims Handling Policy
9. Notification, Reporting, Monitoring and Recordkeeping Requirements
10. Post SSO Event Debriefing
11. Failure Analysis Investigation
12. SSO Response Training
13. Authority
14. References

**Appendix A: Regulatory Notifications Packet**

|   |                 |
|---|-----------------|
| Instructions.....                             | Packet Envelope |
| Regulatory Reporting Guide .....              | A-1             |
| Category 1 SSO Reporting Checklist.....       | A-2a            |
| Category 2 and 3 SSO Reporting Checklist..... | A-2b            |

**Appendix B: Sanitary Sewer Overflow/Backup Response Packet**

|   |                         |
|---|-------------------------|
| Response Instructions and Chain of Custody.....         | Packet Envelope         |
| Sanitary Sewer Overflow/Backup Response Flowchart ..... | B-1                     |
| Start Time Determination Form.....                      | B-2                     |
| Volume Estimation Methods                               |                         |
| Eyeball .....   | B-3a                    |
| Area/Volume .....                                       | B-3b                    |
| Upstream Lateral Connections .....                      | B-3c                    |
| Sewer Overflow Report .....                             | B-4                     |
| Lateral CCTV Report.....                                | B-5                     |
| Bubbled Toilets Letter .....                            | B-6                     |
| First Responder Form .....                              | B-7                     |
| Claims Submittal Checklist.....                         | B-8                     |
| Collection System Failure Analysis Form .....           | B-9                     |
| Customer Service Packet                                 |                         |
| Instructions .....                                      | Envelope                |
| Customer Information.....                               | CS-1                    |
| Sewer Spill Reference Guide .....                       | Pamphlet                |
| Regulatory Notifications Packet .....                   | See Contents List Above |
| Public Posting .....                                    | n/a                     |
| Door Hanger .....                                       | n/a                     |

**Appendix C: Field Sampling Kit**

|  |     |
|--|-----|
| Procedures for Sampling Receiving Waters and Posting |     |
| Warnings after a Sewage Spill.....                   | C-1 |
| Sample Collection Chain of Custody Record.....       | C-2 |

**Appendix D: Contractor Orientation**

# Sanitary Sewer Overflow Emergency Response Plan

(ref. SWRCB Order No. 2006-0003-DWQ Element VI)

## 1 Purpose

The purpose of the City of Davis's Overflow Emergency Response Plan (OERP) is to support an orderly and effective response to Sanitary Sewer Overflows (SSOs). The OERP provides guidelines for City personnel to follow in responding to, cleaning up, and reporting SSOs that may occur within the City's service area. This OERP satisfies the SWRCB Statewide General Waste Discharge Requirements (GWDR), which require wastewater collection agencies to have an Overflow Emergency Response Plan.

## 2 Policy

The City's employees are required to report all wastewater overflows resulting from the City-owned/maintained sanitary sewer system found and to take the appropriate action to secure the wastewater overflow area, properly report to the appropriate regulatory agencies, relieve the cause of the overflow, and ensure that the affected area is cleaned as soon as possible to minimize health hazards to the public and protect the environment. The City's goal is to respond to sewer system overflows as soon as possible following notification. The City will follow reporting procedures in regards to sewer spills as set forth by the Central Valley Regional Water Quality Control Board (CVRWQCB) and the California State Water Resources Control Board (SWRCB).

## 3 Goals

The City's goals with respect to responding to SSOs are:

- Work safely;
- Respond quickly to minimize the volume of the SSO;
- Eliminate the cause of the SSO;
- Prevent sewage system overflows or leaks from entering the storm drain system or receiving waters to the maximum extent practicable;
- Contain the spilled wastewater to the extent feasible;
- Minimize public contact with the spilled wastewater;
- Mitigate the impact of the SSO;
- Meet the regulatory reporting requirements;
- Evaluate the causes of failure related to certain SSOs; and
- Revise response procedures resulting from the debrief and failure analysis of SSOs.

## 4 SSO Detection and Notification

*ref. SWRCB Order No. 2006-0003-DWQ VI(a)*

The processes that are employed to notify the City of the occurrence of an SSO include: observation by the public, receipt of an alarm, or observation by City staff during the normal course of their work.

The City operates wastewater pump stations. In the event of any pump failure, the high level sensor activates the SCADA alarm system and the City is contacted. To prevent overflow, wastewater from the wet well can either be pumped into a vacuum truck for disposal to a nearby sanitary sewer maintenance hole, or bypassed around the station into the sanitary sewer system. Each pump station has an emergency response plan that can be followed in the event of a pump failure.

#### **4.1 Public Observation**

Public observation is the most common way that the City is notified of blockages and spills. Contact numbers and information for reporting sewer spills and backups are in the phone book and on the City's website [www.cityofdavis.org](http://www.cityofdavis.org). Customers can report sewer problems by telephone at (530) 757-5686 during business hours or (530) 758-3600 (Police Dispatch) after hours.

##### Normal Work Hours

When a report of a sewer spill or backup is made during normal work hours, the office staff takes the call and creates a Lucity Service Request and notifies the Collections Crew or the Field Crew.

##### After Hours

After hours callers will receive a voice message instructing them to call Police Dispatch at (530) 758-3600. Police Dispatch will notify the On Call Standby Employee.

When calls are received, either during normal work hours or after hours, the individual receiving the call will collect the following information:

- Time and date of call
- Specific location of potential problem
- Nature of call
- In case of SSO, estimated start time of overflow
- Caller's name, address and telephone number
- Caller's observation (e.g., odor, duration, location on property, known impacts, indication if surface water impacted, appearance at cleanout or maintenance hole)
- Other relevant information

The following (Figure 4.1) is an overview of receiving a sewage overflow or backup report:



Figure 4.1 Overview of Receiving a Sewage Overflow or Backup Report Procedure

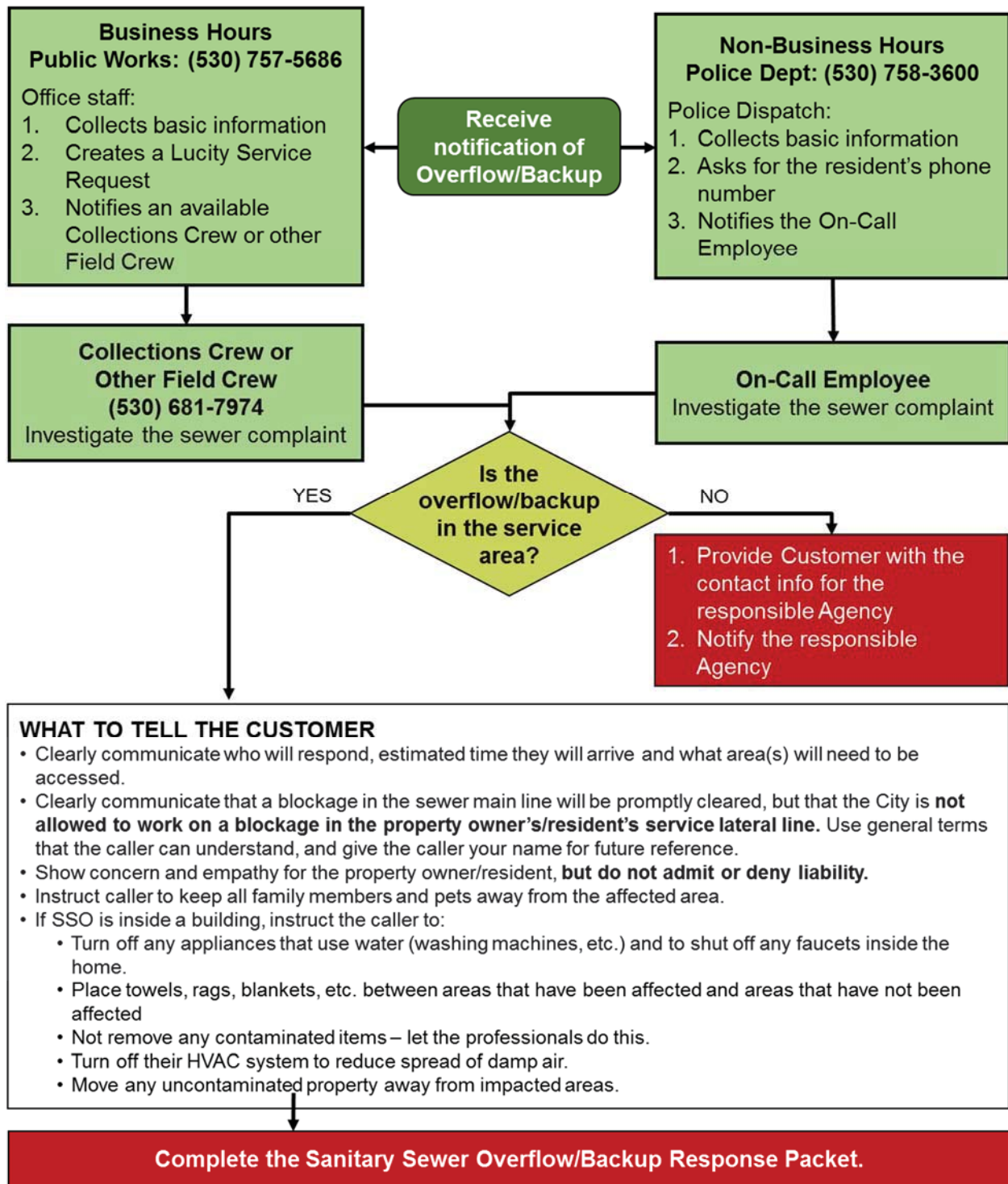

Adapted with permission from: DKF Solutions Group, LLC

## **4.2 City Staff Observation**

City staff conducts periodic inspections of its sewer system facilities as part of their routine activities. Any problems noted with the sewer system facilities are reported to appropriate City staff that, in turn, responds to emergency situations. Work orders are issued to correct non-emergency conditions.

## **4.3 Contractor Observation**

The following procedures are to be followed in the event that a contractor/plumber causes or witnesses a Sanitary Sewer Overflow. If the contractor/plumber causes or witnesses an SSO they should:

1. Immediately notify the City: Business hours (530) 757-5686, After hours (530) 758-3600.
2. Protect storm drains
3. Protect the public
4. Provide Information to the City Collections Crew or other Field Crew such as start time, appearance point, suspected cause, weather conditions, etc.
5. Direct ALL media and public relations requests to the Wastewater Division Manager, at (530) 747-8283, who will provide the media with all relevant information.

## 5 SSO Response Procedures

ref. SWRCB Order No. 2006-0003-DWQ Element 6(b)

### 5.1 Sewer Overflow/Backup Response Summary

The City will respond to SSOs as soon as feasible following notification of an overflow/backup or unauthorized discharge. The following (Figure 5.1) is an overview of the response activities.

Figure 5.1 Overview of SSO/Backup Response

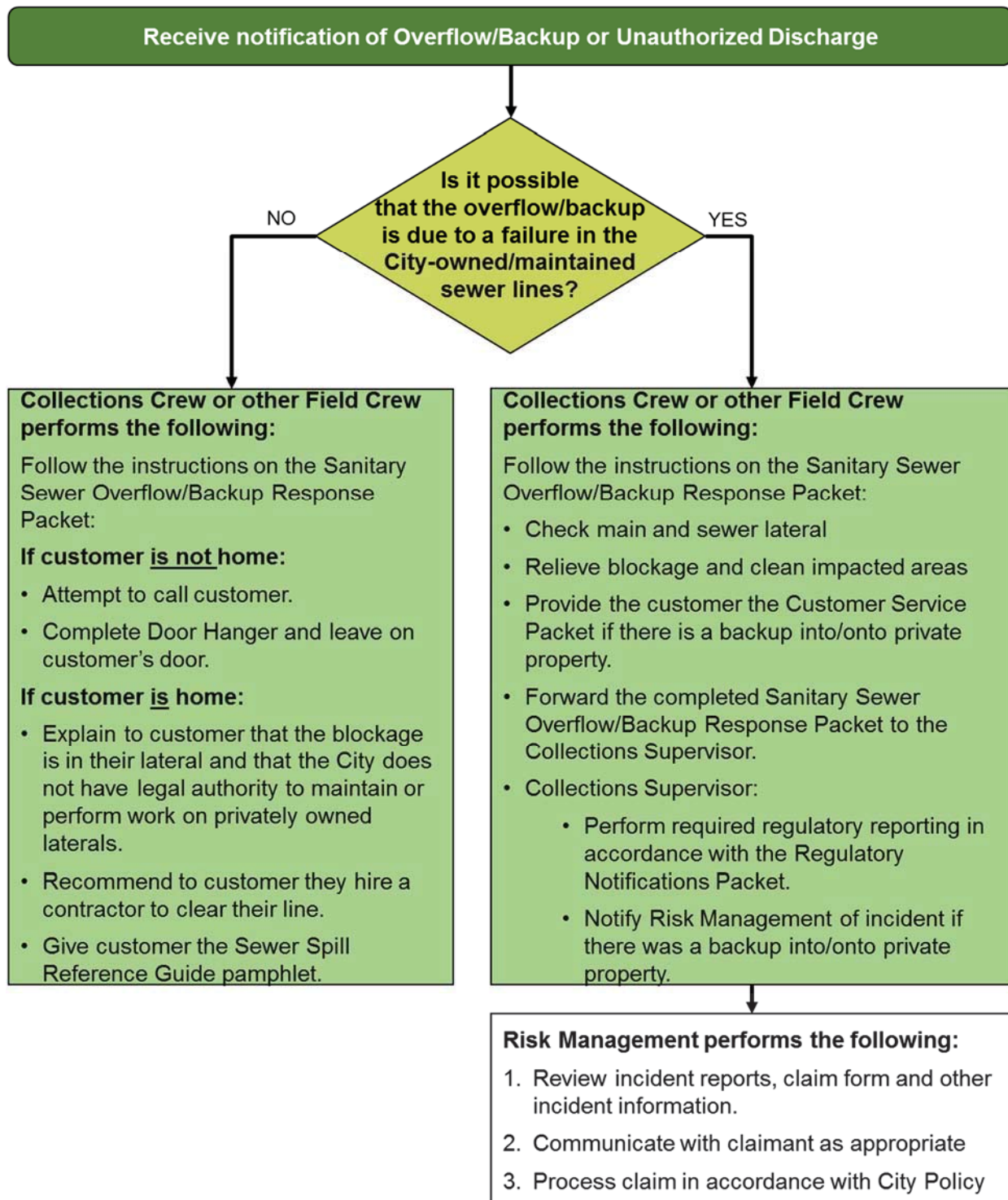

Adapted with permission from: DKF Solutions Group, LLC



## **5.2 First Responder Priorities**

The first responder's priorities are:

- To follow safe work practices.
- To respond promptly with the appropriate and necessary equipment and call the Hydro-Cleaning Crew or other crew.
- To contain the spill wherever feasible.
- To restore the flow as soon as practicable.
- To minimize public access to and/or contact with the spilled sewage.
- To promptly notify the Collections Supervisor in event of major SSO.
- To return the spilled sewage to the sewer system.
- To restore the area to its original condition (or as close as possible).
- To photograph or video field conditions of the SSO.

## **5.3 Safety**

The first responder is responsible for following safety procedures at all times. Special safety precautions must be observed when performing sewer work. There may be times when City personnel responding to a sewer system event are not familiar with potential safety hazards peculiar to sewer work. In such cases it is appropriate to take the time to discuss safety issues, consider the order of work, and check safety equipment before starting the job.

## **5.4 Initial Response**

The first responder must respond to the reporting party/problem site and visually check for potential sewer stoppages or overflows.

The first responder will:

- Note arrival time at the site of the overflow/backup.
- Verify the existence of a sewer system spill or backup.
- Determine if the overflow or blockage is from a City-owned/maintained or private sewer.
- Identify and assess the affected area and extent of spill.
- Contact additional collections personnel for SSO response.
- Contact caller if time permits.
- If the spill is large or in a sensitive area, document conditions upon arrival with photographs. Decide whether to proceed with clearing the blockage to restore the flow or to initiate containment measures. The guidance for this decision is:
  - Small spills (i.e., spills that are easily contained) – proceed with clearing the blockage.
  - Moderate or large spill where containment is anticipated to be simple – proceed with the containment measures.
  - Moderate or large spills where containment is anticipated to be difficult – proceed with clearing the blockage; however, whenever deemed necessary, call for additional assistance and implement containment measures.
- Take steps to contain the SSO. For detailed procedures refer to Appendix B: Sanitary Sewer Overflow/Backup Response Packet.

## **5.5 Initiate Spill Containment Measures**

The first responder will attempt to contain as much of the spilled sewage as possible using the following steps:

- Determine the immediate destination of the overflowing sewage.
- Plug storm drains using air plugs, sandbags, and/or plastic mats to contain the spill, whenever appropriate. If spilled sewage has made contact with the storm drainage system, attempt to contain the spilled sewage by plugging downstream storm drainage facilities.
- Contain/direct the spilled sewage using dike/dam or sandbags.
- Pump around the blockage/pipe failure.

For detailed procedures refer to Appendix B: Sanitary Sewer Overflow/Backup Response Packet.

## 5.6 Restore Flow

Using the appropriate cleaning equipment, the Hydro Cleaning Crew will set up downstream of the blockage and hydro-clean upstream from a clear maintenance hole. Attempt to remove the blockage from the system and observe the flows to ensure that the blockage does not reoccur downstream. If the blockage cannot be cleared within a reasonable time from arrival, or sewer requires construction repairs to restore flow, then initiate containment and/or bypass pumping. If other assistance is required, immediately contact the Wastewater Division Manager. For detailed procedures refer to Appendix B: Sanitary Sewer Overflow/Backup Response Packet.

## 5.7 Equipment

This section provides a list of specialized equipment that may be used to support this Overflow Emergency Response Plan.

- *Closed Circuit Television (CCTV) Inspection Unit* – A CCTV Inspection Unit is required to determine the root cause for all SSOs from gravity sewers.
- *Camera* -- A digital camera is required to record the conditions upon arrival, during clean up, and upon departure.
- *Emergency Response Trucks* -- A utility body pickup truck, or open bed is required to store and transport the equipment needed to effectively respond to sewer emergencies. The equipment and tools will include containment and clean up materials.
- *Portable Generators, Portable Pumps, Piping, and Hoses* – Equipment used to bypass pump, divert, or power equipment to mitigate an SSO.
- *Combination Sewer Cleaning Trucks* -- Combination high velocity sewer cleaning trucks with vacuum tanks are required to clear blockages in gravity sewers, vacuum spilled sewage, and wash down the impacted area following the SSO event.
- Air plugs, sandbags and plastic mats
- Portable Lights

# 6 Recovery and Cleanup

ref. SWRCB Order No. 2006-0003-DWQ Element 6(e)

The recovery and cleanup phase begins immediately after the flow has been restored and the spilled sewage has been contained to the extent possible. The SSO recovery and cleanup procedures are:

## 6.1 Estimate the Volume of Spilled Sewage

Use the methods outlined in the Sanitary Sewer Overflow/Backup Response Packet (Appendix B) and/or the Field Guide to estimate the volume of the spilled sewage. Wherever possible, document the estimate using photos and/or video of the SSO site before and during the recovery operation.

## **6.2 Recovery of Spilled Sewage**

Vacuum up and/or pump the spilled sewage and rinse water, and discharge it back into the sanitary sewer system.

## **6.3 Clean-up and Disinfection**

Clean up and disinfection procedures will be implemented to reduce the potential for human health issues and adverse environmental impacts that are associated with an SSO event. The procedures described are for dry weather conditions and will be modified as required for wet weather conditions. Where cleanup is beyond the capabilities of the Field Crew, a cleanup contractor will be used.

### Private Property

City crews are responsible for the cleanup when the property damage is minor in nature and is outside of private building dwellings, such as in front, side and backyards, easements, etc. In all other cases, affected property owners can call a water damage restoration contractor to complete the cleanup and restoration. If the overflow into property is the definite cause of City system failure, the property owner can call out a water damage restoration contractor to complete the cleanup and restoration. In both cases, property owners may obtain a City claim form from the Management Analyst.

### Hard Surface Areas

Collect all signs of sewage solids and sewage-related material either by protected hand or with the use of rakes and brooms. Wash down the affected area with clean water and/or deozyme or similar non-toxic biodegradable surface disinfectant until the water runs clear. The flushing volume will be approximately three times the estimated volume of the spill. Take reasonable steps to contain and vacuum up the wastewater. Allow area to dry. Repeat the process if additional cleaning is required.

### Landscaped and Unimproved Natural Vegetation

Collect all signs of sewage solids and sewage-related material either by protected hand or with the use of rakes and brooms. Wash down the affected area with clean water until the water runs clear. The flushing volume will be approximately three times the estimated volume of the spill. Either contain or vacuum up the wash water so that none is released. Allow the area to dry. Repeat the process if additional cleaning is required.

### Natural Waterways

The Department of Fish and Wildlife will be notified by CalOES for SSOs greater than or equal to 1,000 gallons.

### Wet Weather Modifications

Omit flushing and sampling during heavy storm events (i.e., sheet of rainwater across paved surfaces) with heavy runoff where flushing is not required and sampling would not provide meaningful results.

## **6.4 Public Notification**

Signs will be posted and barricades put in place to keep vehicles and pedestrians away from contact with spilled sewage. The Collections Supervisor or the Wastewater Division Manager shall direct placement and language of public warnings that will be followed. Additionally, the Collections Supervisor will use their best judgment regarding supplemental sign placement in order to protect the public and local environment. Signs will not be removed until directed by County Environmental Health, the Collections Supervisor or designee.

Creeks, streams and beaches that have been contaminated as a result of an SSO will be posted at visible access locations until the risk of contamination has subsided to acceptable background bacteria levels. The area and warning signs, once posted, will be checked every day to ensure that they are still in place. Photographs of sign placement will be taken.



In the event that an overflow occurs at night, the location will be inspected first thing the following day. The field crew will look for any signs of sewage solids and sewage-related material that may warrant additional cleanup activities.

When contact with the local media is deemed necessary, the City Public Information Officer or the Wastewater Division Manager or their designee will provide the media with all relevant information.

## **7 Water Quality**

*ref. SWRCB Order No. 2006-0003-DWQ Element 6(f)*

### **7.1 Waters of the State**

Waters of the State (or waters of the United States) means any surface water, including saline waters, within the boundaries of California. In case of a sewage spill, catch basins, storm drains and retention basins are considered to be waters of the State unless the sewage is completely contained and returned to the sanitary sewer collection system and that portion of the storm drain is cleaned.

### **7.2 Water Quality Sampling and Testing**

Water quality sampling and testing is required for Category 1 SSOs of 50,000 gallons or greater to determine the extent and impact of the SSO. The water quality sampling procedures must be implemented within 48 hours and include the following:

- The first responders will collect samples as soon as possible after the discovery and mitigation of the SSO event.
- The water quality samples will be collected from upstream of the spill, from the spill area, and downstream of the spill in flowing water (e.g. creeks). The water quality samples will be collected near the point of entry of the spilled sewage.
- The samples shall then be brought to the City of Davis Sewage Treatment Plant Laboratory for analysis.

### **7.3 Water Quality Monitoring Plan**

The City Water Quality Monitoring Plan will be implemented immediately upon discovery of any Category 1 SSO of 50,000 gallons or more in order to assess impacts from SSOs to surface waters. The SSO Water Quality Monitoring Program will:

1. Contain protocols for water quality monitoring.
2. Account for spill travel time in the surface water and scenarios where monitoring may not be possible (e.g. safety, access restrictions, etc.)
3. Require water quality analyses for ammonia and bacterial indicators to be performed by an accredited or certified laboratory.
4. Require monitoring instruments and devices used to implement the SSO Water Quality Monitoring Program to be properly maintained and calibrated, including any records to document maintenance and calibration, as necessary, to ensure their continued accuracy.
5. Within 48 hours of the City becoming aware of the SSO, require water quality sampling for ammonia and total and fecal coliform or other parameters as directed by the CVRWQCB Basin Plan.
6. Observe proper chain of custody procedures.

### **7.4 SSO Technical Report**

The City will submit an LRO certified SSO Technical Report to the CIWQS Online SSO Database within 45 calendar days of the SSO end date for any SSO in which 50,000 gallons or greater are spilled to

surface waters. The Wastewater Division Manager will supervise the preparation of this report and will certify this report. This report, which does not preclude the Water Boards from requiring more detailed analyses if requested, shall include at a minimum, the following:

Causes and Circumstances of the SSO:

- Complete and detailed explanation of how and when the SSO was discovered.
- Documented contact information from the original caller and any others interviewed at the site.
- Diagram showing the SSO failure point, appearance point(s), and final destination(s).
- Detailed description of the methodology employed and available data used to calculate the volume of the SSO and, if applicable, the SSO volume recovered.
- Detailed description of the cause(s) of the SSO.
- Copies of original field crew records used to document the SSO.
- Historical maintenance records for the failure location.

City's Response to SSO:

- Chronological narrative description of all actions taken by the City to terminate the spill.
- Explanation of how the SSMP Overflow Emergency Response Plan was implemented to respond to and mitigate the SSO.
- Final corrective action(s) completed and/or planned to be completed, including a schedule for actions not yet completed.

Water Quality Monitoring:

- Description of all water quality sampling activities conducted including analytical results and evaluation of the results.
- Detailed location map illustrating all water quality sampling points.

## **8 Sewer Backup Into/Onto Private Property Claims Handling Procedure**

It is the procedure of the City that a claims form shall be offered to anyone wishing to file a claim. The following procedures will be observed for all sewer overflows/backups into/onto private property:

- Collections Crew or other Field Crew will offer a City claim form whenever it is possible that the sanitary sewer backup may have resulted from an apparent blockage in the City-owned sewer lines or whenever a City customer requests a claim form. The claim may later be rejected if subsequent investigations into the cause of the loss indicate the City was not at fault.
- It is the responsibility of the Field Crew to gather information regarding the incident and notify the Collections Supervisor or his/her designee.
- It is the responsibility of Risk Management to review all claims and to oversee the adjustment and administration of the claim to closure.

## **9 Notification, Reporting, Monitoring and Recordkeeping Requirements**

*ref. SWRCB Order No. 2006-0003-DWQ Element 6(c)*

In accordance with the Statewide General Waste Discharge Requirements for Sanitary Sewer Systems (SSS GWDRs) and the most recent Monitoring and Reporting Program (MRP), the City of Davis maintains records for each sanitary sewer overflow. Records include:

- Documentation of response steps and/or remedial actions
- Photographic evidence to document the extent of the SSO, field crew response operations, and site conditions after field crew SSO response operations have been completed. The date, time, location, and direction of photographs taken will be documented.

- Documentation of how any estimations of the volume of discharged and/or recovered volumes were calculated including all assumptions made.
- Documentation of emergency start time.
- All records required by the MRP.
- Electronic monitoring records relied upon in volume estimation.

Regulator required notifications are outlined in Section 9.1 on the following page.



## 9.1 Regulator Required Notifications

| Element                         | Requirement  | Method  |
|---------------------------------|--|---|
| <b>Notification</b>             | Within two hours of becoming aware of any Category 1 SSO greater than or equal to 1,000 gallons discharged to surface water or spilled in a location where it probably will be discharged to surface water, the City will notify the California Office of Emergency Services (CalOES) and obtain a notification control number.  | Call Cal OES at:<br>(800) 852-7550  |
| <b>Reporting</b>                | <ul style="list-style-type: none"> <li>• Category 1 SSO: The City will submit draft report within three business days of becoming aware of the SSO and certify within 15 calendar days of SSO end date.</li> <li>• Category 2 SSO: The City will submit draft report within 3 business days of becoming aware of the SSO and certify within 15 calendar days of the SSO end date.</li> <li>• Category 3 SSO: The City will submit certified report within 30 calendar days of the end of month in which SSO the occurred.</li> <li>• SSO Technical Report: The City will submit within 45 calendar days after the end date of any Category 1 SSO in which 50,000 gallons or greater are spilled to surface waters.</li> <li>• "No Spill" Certification: The City will certify that no SSOs occurred within 30 calendar days of the end of the month or, if reporting quarterly, the quarter in which no SSOs occurred.</li> <li>• Collection System Questionnaire: The City will update and certify every 12 months</li> </ul> | Enter data into the CIWQS Online SSO Database <sup>1</sup> ( <a href="http://ciwqs.waterboards.ca.gov/">http://ciwqs.waterboards.ca.gov/</a> ) certified by the Legally Responsible Official(s) <sup>2</sup> . All information required by CIWQS will be captured in the Sanitary Sewer Overflow Report. Certified SSO reports may be updated by amending the report or adding an attachment to the SSO report within 120 calendar days after the SSO end date. After 120 days, the State SSO Program Manager must be contacted to request to amend an SSO report along with a justification for why the additional information was not available prior to the end of the 120 days. |
| <b>Water Quality Monitoring</b> | The City will conduct water quality sampling within 48 hours after initial SSO notification for Category 1 SSOs in which 50,000 gallons or greater are spilled to surface waters.  | Water quality results will be uploaded into CIWQS for Category 1 SSOs in which 50,000 gallons or greater are spilled to surface waters.   |
| <b>Record Keeping</b>           | The City will maintain the following records: <ul style="list-style-type: none"> <li>• SSO event records.</li> <li>• Records documenting Sanitary Sewer Management Plan (SSMP) implementation and changes/updates to the SSMP.</li> <li>• Records to document Water Quality Monitoring for SSOs of 50,000 gallons or greater spilled to surface waters.</li> <li>• Collection system telemetry records if relied upon to document and/or estimate SSO Volume.</li> </ul>   | Self-maintained records shall be available during inspections or upon request.  |

<sup>1</sup> In the event that the CIWQS online SSO database is not available, the Collections Supervisor will notify SWRCB by phone in accordance with the time schedules identified above. In such an event, the City will submit the appropriate reports using the CIWQS online SSO database when the database becomes available. A copy of all documents that certify the submittal in fulfillment of this section shall be retained in the SSO file.

<sup>2</sup> The City always has at least one LRO. Any change in the LRO(s) including deactivation or a change to contact information, will be submitted to the SWRCB within 30 days of the change by calling (866) 792-4977 or emailing [help@ciwqs.waterboards.ca.gov](mailto:help@ciwqs.waterboards.ca.gov).

For reporting purposes, if one SSO event of whatever category results in multiple appearance points in a sewer system, a single SSO report is required in CIWQS that includes the GPS coordinates for the location of the SSO appearance point closest to the failure point, blockage or location of the flow condition that cause the SSO, and descriptions of the locations of all other discharge points associated with the single SSO event.

## 9.2 Complaint Records

The City maintains records of all complaints received whether or not they result in sanitary sewer overflows. These complaint records include:

- Date, time, and method of notification
- Date and time the complainant or informant first noticed the SSO or occurrence related to the call
- Narrative description describing the complaint
- A statement from the complainant or informant, if they know, of whether or not the potential SSO may have reached waters of the state
- Name, address, and contact telephone number of the complainant or informant reporting the potential SSO (if not reported anonymously)
- Follow-up return contact information for each complaint received (if not reported anonymously)
- Final resolution of the complaint with the original complainant
- Work service request information used to document all feasible and remedial actions taken

All sewer service requests are entered into the Lucity Computerized Maintenance Management System (CMMS). If the service request requires work on the sewer or other City infrastructure, a work order is created. Once work is complete, the Work Order and the Service Request are closed. If the work does require City action, the Service Request is closed in Lucity.

All sewer service requests are logged on the Sewer/SSO Report by the responding field crew. If the service request turns out to not be sewer related, this information is captured on this form and the true nature of the service request identified.

The Collections Supervisor is responsible for maintaining separate files for each completed Sewer SSO Report for five years or as otherwise directed by the CVRWQCB or the SWRCB.

## 10 Post SSO Event Debriefing

*ref. SWRCB Order No. 2006-0003-DWQ Element 6(d)*

Every SSO event is an opportunity to evaluate the City response and reporting procedures. Each overflow event is unique, with its own elements and challenges including volume, cause, location, terrain, climate, and other parameters.

As soon as possible after Category 1 and Category 2 SSO events all of the participants, from the person who received the call to the last person to leave the site, will meet to review the procedures used and to discuss what worked and where improvements could be made in preventing or responding to and mitigating future SSO events. The results of the debriefing will be documented (including attendees, summary of discussions, action items identified and assignments and schedules for completion and tracked to ensure the action items are completed as scheduled.

## 11 Failure Analysis Investigation

*ref. SWRCB Order No. 2006-0003-DWQ Element 6(d)*

The objective of the failure analysis investigation is to determine the “root cause” of the SSO and to identify corrective action(s) needed that will reduce or eliminate future potential for the SSO to recur or for other SSOs to occur.

The investigation will include reviewing all relevant data to determine appropriate corrective action(s) for the line segment. The investigation will include:

- Reviewing and completing the Sanitary Sewer Overflow Report (in Appendix B) and any other documents related to the incident
- Reviewing the incident timeline and other documentation regarding the incident
- SSO start time documentation
- Reviewing communications with the reporting party and witness
- Reviewing volume estimate, volume recovered estimate, volume estimation assumptions and associated drawings and maps of the impacted area(s)
- Reviewing available photographs and video of the incident
- Interviewing staff that responded to the spill
- Reviewing past maintenance records and SCADA records if utilized.
- Reviewing past CCTV records,
- Conducting a CCTV inspection to determine the condition of all line segments immediately following the SSO and reviewing the video and logs,
- Reviewing any Fats, Oils, Roots and Grease (FROG) related information or results
- Post SSO debrief records
- Documented interviews with the public at the SSO location

The product of the failure analysis investigation will be the determination of the root cause and the identification and scheduling of the corrective actions. The Collection System Failure Analysis Form (in Appendix B) will be used to document the investigation.

## **12 SSO Response Training**

ref. SWRCB Order No. 2006-0003-DWQ Element 6(d)

This section provides information on the training that is required to support this Overflow Emergency Response Plan.

### **12.1 Initial and Annual Refresher Training**

All City personnel who may have a role in responding to, reporting, and/or mitigating a sewer system overflow will receive training on the contents of this OERP. All new employees will receive training before they are placed in a position where they may have to respond. Current employees will receive annual refresher training on this plan and the procedures to be followed. The City will document all training.

Affected employees will receive annual training on the following topics by knowledgeable trainers:

- The City's Overflow Emergency Response Plan and Sanitary Sewer Management Plan
- Sanitary Sewer Overflow Volume Estimation Techniques
- Researching and documenting Sanitary Sewer Overflow Start Times
- Impacted Surface Waters: Response Procedures
- State Water Resources Control Board Employee Knowledge Expectations
- Employee Core Competency Evaluations on Sanitary Sewer Operations
- Water Quality Sampling Plan

The City will verify that annual safety training requirements are current for each employee, and that employees are competent in the performance of all core competencies. This will be verified through electronic testing, interviews and observations. The City will address, through additional training/instruction, any identified gaps in required core competencies.



Through SWRCB Employee Knowledge Expectations training the employee will be able to answer the following:

1. Please briefly describe your name and job title.
2. Please describe for us approximately when you started in this field and how long you have worked for your agency.
3. Please expand on your current position duties and role in responding in the field to any SSO complaints.
4. Please describe your SOPs used to respond/mitigate SSOs when they occur.
5. Describe any training your agency provides or sends you to for conducting spill volume estimates.
6. We are interested in learning more about how your historical SSO response activities have worked in the field. We understand from discussions with management earlier that you use the OERP from the SSMP. Please elaborate on how you implement and utilize the procedures in the plan.
7. Historically, before any recent changes, can you please walk us through how you would typically receive and respond to any SSO complaints in the field?
8. Can you tell us who is responsible for estimating SSO volumes discharged? If it is you, please describe how you go about estimating the SSO volume that you record on the work order/service request forms?
9. What other information do you collect or record other than what is written on the work order form?
10. Describe if and when you ever talk with people that call in SSOs (either onsite or via telephone) to further check out when the SSO might have occurred based on what they or others know? If you do this, can you tell us where this information is recorded?
11. We understand you may be instructed to take pictures of some sewer spills/backups into structures. Other than these SSOs, when else would you typically take any pictures of an SSO?
12. Please walk us through anything else you'd like to add to help us better understand how your field crews respond and mitigate SSO complaints.

## **12.2 SSO Response Drills**

Periodic training drills or field exercises will be held to ensure that employees are up to date on these procedures, equipment is in working order, and the required materials are readily available. The training drills will cover scenarios typically observed during sewer related emergencies (e.g. mainline blockage, mainline failure, and lateral blockage). The results and the observations during the drills will be recorded and corrective action items or procedures changes will be tracked to ensure completion and identified in the SSMP Change Log.

## **12.3 SSO Training Record Keeping**

Records will be kept of all training that is provided in support of this plan. The records for all scheduled training courses and for each overflow emergency response training event and will include date, time, place, content, name of trainer(s), and names and titles of attendees.

## **12.4 Contractors Working On City Sewer Facilities**

All construction contractors working on City sewer facilities will be required to develop a project-specific OERP, will provide project personnel with training regarding the content of the contractor's OERP and their role in the event of an SSO, and to follow that OERP in the event that they cause or observe an SSO. Emergency response procedures shall be discussed at project pre-construction meetings, regular project meetings and after any contractor involved incidents.

All service contractors will be provided, and required to observe contractor procedures. See Appendix D: Contractor Orientation.

## **13 Authority**

- Health & Safety Code Sections 5410-5416
- CA Water Code Section 13271
- Fish & Wildlife Code Sections 5650-5656
- State Water Resources Control Board Order No. 2006-0003-DWQ
- State Water Resources Control Board Order 2013-009-DWQ effective September 9, 2013

## **14 References**

- SWRCB Order No. 2006-DWQ
- SWRCB Order No. WQ 2013-0058-EXEC
- Sanitary Sewer Overflow and Backup Response Field Guide, 2014, DKF Solutions Group, LLC
- Appendix A: Regulatory Notifications Packet
- Appendix B: Sanitary Sewer Overflow/Backup Response Packet
- Appendix C: Field Sampling Kit
- Appendix D: Contractor Orientation

**Appendix A**

**REGULATORY NOTIFICATIONS PACKET**



**Instructions:**

1. Receive call from office staff or Police Department reporting a Sanitary Sewer Overflow.
2. Open this packet.
3. Refer to the Regulatory Reporting Guide (A-1) for instructions.
4. Use the SSO Reporting Checklist for the appropriate category of spill (A-2a or A-2b) to document that all notifications are made according to the reporting schedule.

**Contents:**

| <u>Form</u>                                   | <u>Page Number</u> |
|---|--------------------|
| Regulatory Reporting Guide .....              | A-1                |
| Reporting Checklist: Category 1 .....         | -2a                |
| Reporting Checklist: Categories 2 and 3 ..... | -2b                |

**Regulatory Notifications Packet  
Regulatory Reporting Guide**

| Reporting Instructions                                    |   |   |   |                            |
|---|---|---|---|----------------------------|
| Deadline  | See reverse side for contact information and definitions of the categories of spills of untreated or partially treated wastewater from publically owned sanitary sewer system |   |   | Spill from Private Lateral |
|   | Category 1  | Category 2  | Category 3  |                            |
| 2 hours after awareness of SSO                            | If the SSO is greater than or equal to 1,000 gallons, call CalOES at (800) 852-7550   | -   | -   | -                          |
| 48 Hours after awareness of SSO                           | If 50,000 gal or more will likely reach receiving waters, begin water quality sampling and initiate impact assessment   | -   | -   | -                          |
| 3 Days after awareness of SSO                             | Submit Draft Spill Report in the CIWQS* database  | Submit Draft Spill Report in the CIWQS* database  | -   | -                          |
| 15 Days after response conclusion                         | Certify Spill Report in CIWQS*. Update as needed until 120 days after SSO end time  | Certify Spill Report in the CIWQS* database. Update as needed until 120 days after SSO end time | -   | -                          |
| 30 Days after end of calendar month in which SSO occurred | -   | -   | Certify Spill Report in the CIWQS* database. Update as needed until 120 days after SSO end time | -                          |
| 45 days after SSO end date                                | If 50,000 gal or more were not recovered, submit SSO Technical Report using CIWQS*  | -   | -   | -                          |

\* In the event that the CIWQS online SSO database is not available, notify the State Water Resources Control Board (SWRCB) by phone or email until the CIWQS online SSO database becomes available: (See contact information on Side B)

**Note:** For reporting purposes, if one SSO event results in multiple appearance points, complete one SSO report in the CIWQS SSO Online Database, and report the location of the SSO failure point, blockage or location of the flow condition that caused the SSO, in the CIWQS SSO Online Database, including all the discharge points associated with the SSO event.

**Regulatory Notifications Packet  
Regulatory Reporting Guide**

**Contact Information**

| Contact  | Telephone/Fax/Email  |
|--|--|
| City Risk Management   | (530) 757-5644   |
| CalOES   | (800) 852-7550   |
| Yolo County Environmental Health Division                      | (530) 666-8646   |
| Central Valley Regional Water Quality Control Board (CVRWQCB): | Telephone: (916) 464-3291<br>Fax: (916) 464-4645   |
| State Water Resources Control Board (SWRCB):                   | Gil Vazquez, Water Resources Control Engineer<br>(916) 322-1400 Gil.Vasquez@waterboards.ca.gov |

**Authorized Personnel**

The following individuals are the City’s Legally Responsible Officials (LROs) and are authorized to perform regulatory reporting and to electronically sign and certify SSO reports in the CIWQS online reporting database.

| Contact Name   | Title                           | Telephone      |
|----------------|---------------------------------|----------------|
| John Alexander | Wastewater Division Manager     | (530) 747-8283 |
| Stan Gryczko   | Assistant Public Works Director | (530) 757-8292 |

**Definitions of SSO Categories**

The response crew will complete the SSO Report form in the SSO Packet to document how the category was determined.

| Category           | Definition  |
|--------------------|---|
| <b>Category 1:</b> | Discharge of untreated or partially treated wastewater of any volume resulting from a sanitary sewer system failure or flow condition that either: <ul style="list-style-type: none"> <li>• Reaches surface water and/or drainage channel tributary to a surface water; or</li> <li>• Reached a Municipal Separate Storm Sewer System (MS4) and was not fully captured and returned to the sanitary sewer system or otherwise captured and disposed of properly.</li> </ul> |
| <b>Category 2:</b> | Discharge of untreated or partially treated wastewater greater than or equal to 1,000 gallons resulting from a sanitary sewer system failure or flow condition that either: <ul style="list-style-type: none"> <li>• Does not reach surface water, a drainage channel, or an MS4, or</li> <li>• The entire SSO discharged to the storm drain system was fully recovered and disposed of properly.</li> </ul>  |
| <b>Category 3:</b> | All other discharges of untreated or partially treated wastewater resulting from a sanitary sewer system failure or flow condition  |

Use this Checklist for Category 1 SSOs only

**STEP 1: Receive call from crew.**

**STEP 2: 2-hour Notification**

If the SSO is greater than or equal to 1,000 gallons, notify CalOES within 2 hours of the time the City was notified of the SSO.

**Notify CalOES** at (800) 852-7550:

- o Date Called: \_\_\_\_\_
- o Time called: \_\_\_\_\_ : \_\_\_\_\_ AM PM
- o CalOES Control number: \_\_\_\_\_
- o City personnel who called CalOES: *Name* \_\_\_\_\_  
*Title* \_\_\_\_\_
- o Individual they spoke to at CalOES: \_\_\_\_\_

**STEP 3: Within 2 hours after awareness of SSO**

- If SSO impacts private property that may be due to a failure in the City sewer and/or if the City believes a claim for damages may be submitted against the City notify Risk Management.

**STEP 4: Within 48 hours after awareness of SSO**

- Only if 50,000 gallons or more was not recovered, implement Water Quality Monitoring Plan.

**STEP 5: Within 3 Days after awareness of SSO**

- Submit a Draft Spill Report using the CIWQS online reporting database.

**STEP 6: Within 15 Days after response conclusion**

- LRO must certify the Spill Report using the CIWQS online reporting database. Amendments to the Spill Report may be made for up to 120 days following the conclusion of the SSO Response.

**STEP 7: Within 45 Days after SSO end date**

- Within 45 days after the SSO end date, submit an SSO Technical Report using the CIWQS online reporting database only if 50,000 gallons or more was spilled to surface waters.

This form completed by: \_\_\_\_\_  
*Name* *Title* *Date*



Use this Checklist for Category 2 and 3 SSOs only

**STEP 1: Receive call from crew.**

**STEP 2: Within 2 hours after awareness of SSO**

- If SSO impacts private property that may be due to a failure in the City sewer and/or if the City believes a claim for damages may be submitted against the City notify Risk Management.

**STEP 3: Submit Draft Spill Report (Category 2 only)**

- Submit a Draft Spill Report using the CIWQS online reporting database within 3 days after awareness of Category 2 SSO.

**STEP 4: Certify Spill Report**

- Certify the Spill Report using the CIWQS online reporting database:
  - Category 2 SSO: Within 15 days after the conclusion of the response
  - Category 3 SSO: Within 30 days after the end of the calendar month in which the SSO occurred
- Updates to the Spill Report may be made for up to 120 days following the conclusion of the SSO Response.

This form completed by: \_\_\_\_\_ Title \_\_\_\_\_ Date \_\_\_\_\_  
*Name* *Title* *Date*

**Appendix B**

**SANITARY SEWER OVERFLOW/BACKUP RESPONSE PACKET**

Sanitary Sewer Overflow/Backup Response Packet  
Table of Contents

| <b><u>Form</u></b>                                      | <b><u>Form Number</u></b> |
|---|---------------------------|
| Response Instructions and Chain of Custody .....        | Packet Envelope           |
| Sanitary Sewer Overflow/Backup Response Flowchart ..... | B-1                       |
| Start Time Determination Form .....                     | B-2                       |
| Volume Estimation Methods                               |                           |
| Eyeball Estimation .....                                | B-3a                      |
| Area/Volume Estimation .....                            | B-3b                      |
| Upstream Lateral Connections .....                      | B-3c                      |
| Manhole Overflow Flowrate .....                         | B-3d                      |
| Sewer Overflow Report .....                             | B-4                       |
| Lateral CCTV Report.....                                | B-5                       |
| Bubbled Toilets Letter .....                            | B-6                       |
| First Responder Form .....                              | B-7                       |
| Claims Submittal Checklist.....                         | B-8                       |
| Collection System Failure Analysis Form.....            | B-9                       |
| Customer Service Packet                                 |                           |
| Instructions .....                                      | envelope                  |
| Customer Information (English) .....                    | CS-1 English              |
| Customer Information (Spanish) .....                    | CS-1 Spanish              |
| Sewer Spill Reference Guide.....                        | pamphlet                  |
| Regulatory Notifications Packet .....                   | See contents list above   |
| Public Posting .....                                    | n/a                       |
| Door Hanger.....  | n/a                       |

## Sanitary Sewer Overflow/Backup Response Packet.

- If this is a Category 1 SSO greater than or equal to 1,000 gallons immediately** contact CalOES at (800) 852-7550 to make the 2-hour notification.
- If there is a backup into/onto private property AND possibly due to a problem in the public sewer,** notify Risk Management at (530) 757-5644.
- For any media requests,** contact the Wastewater Division Manager at (530) 747-8283.

**Check here if you believe that fats, roots, oil, and grease (FROG) caused/contributed to the SSO:**

### Collection Crew or other Field Crew:

- Follow the instructions on the Sanitary Sewer Overflow/Backup Response Flowchart. Note: If there is a backup and multiple dwelling units are affected, use one packet per unit and check here:
- If indicated on the flowchart, give the customer the Bubbled Toilets Letter and/or the Customer Service Packet and have them initial here:  
*Customer acknowledgement of receipt of Bubbled Toilets Letter* \_\_\_\_\_  
*Customer acknowledgement of receipt of Customer Service Packet* \_\_\_\_\_
- Place completed forms in this envelope, complete the Chain of Custody record (right) and forward this packet to the Collections Supervisor.

### Chain of Custody

Print Name: \_\_\_\_\_

Initial: \_\_\_\_\_

Date: \_\_\_\_\_

Time: \_\_\_\_\_

### Collections Supervisor:

- Follow the instructions on the bottom of the Sanitary Sewer Overflow/Backup Response Flowchart
- Complete the Regulatory Notifications Packet.
- Complete the Chain of Custody Record (right).
- If there is a backup:
  - Complete the Claims Submittal Checklist.
  - Forward this completed packet to Risk Management.
- If no backup, file this completed packet in accordance with City Policy.

### Chain of Custody

Print Name: \_\_\_\_\_

Initial: \_\_\_\_\_

Date: \_\_\_\_\_

Time: \_\_\_\_\_

**Risk Management:** Refer to the Claims Submittal Checklist.



**Sanitary Sewer Overflow/Backup Response Flowchart**

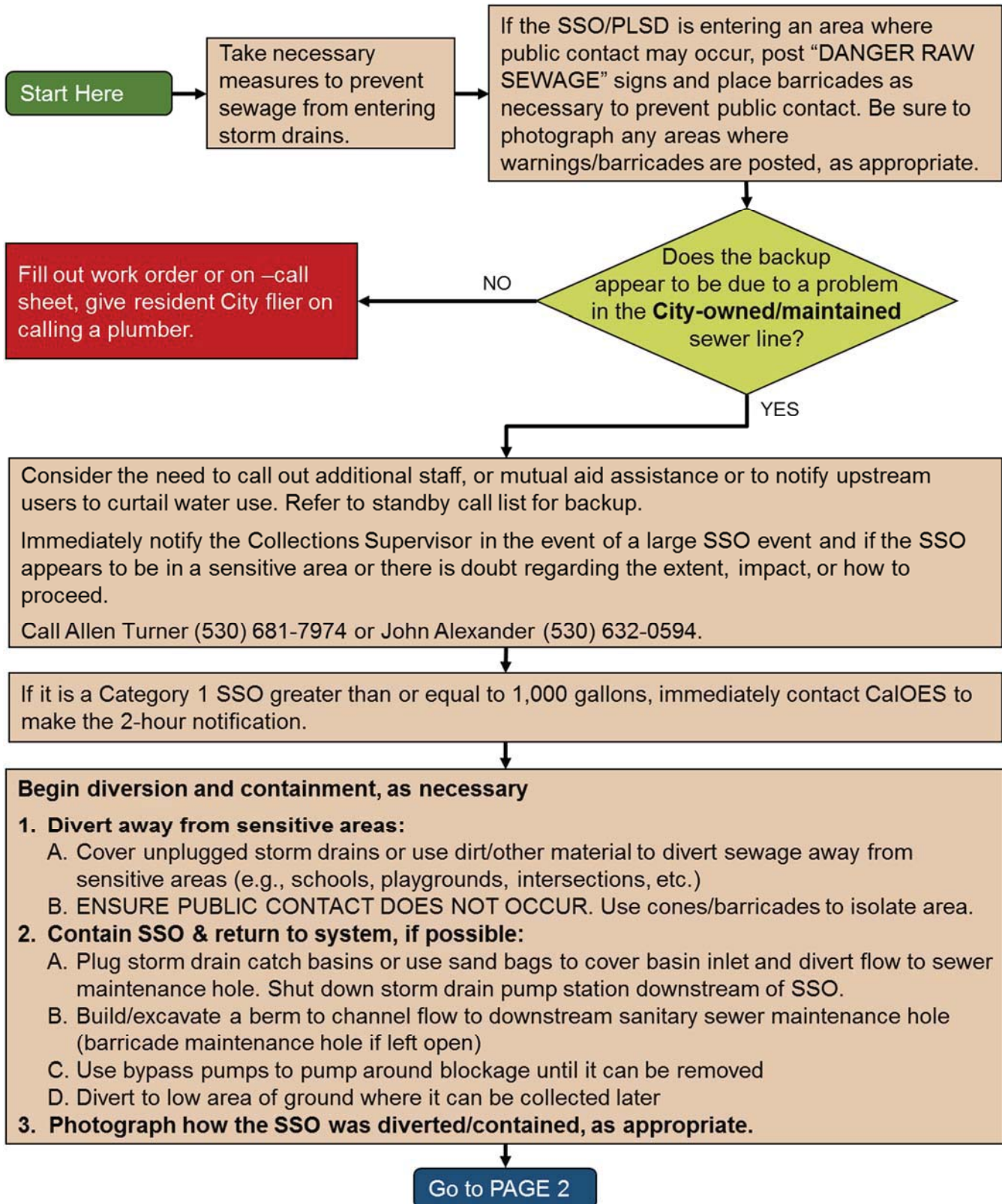

**Sanitary Sewer Overflow/Backup Response Flowchart**

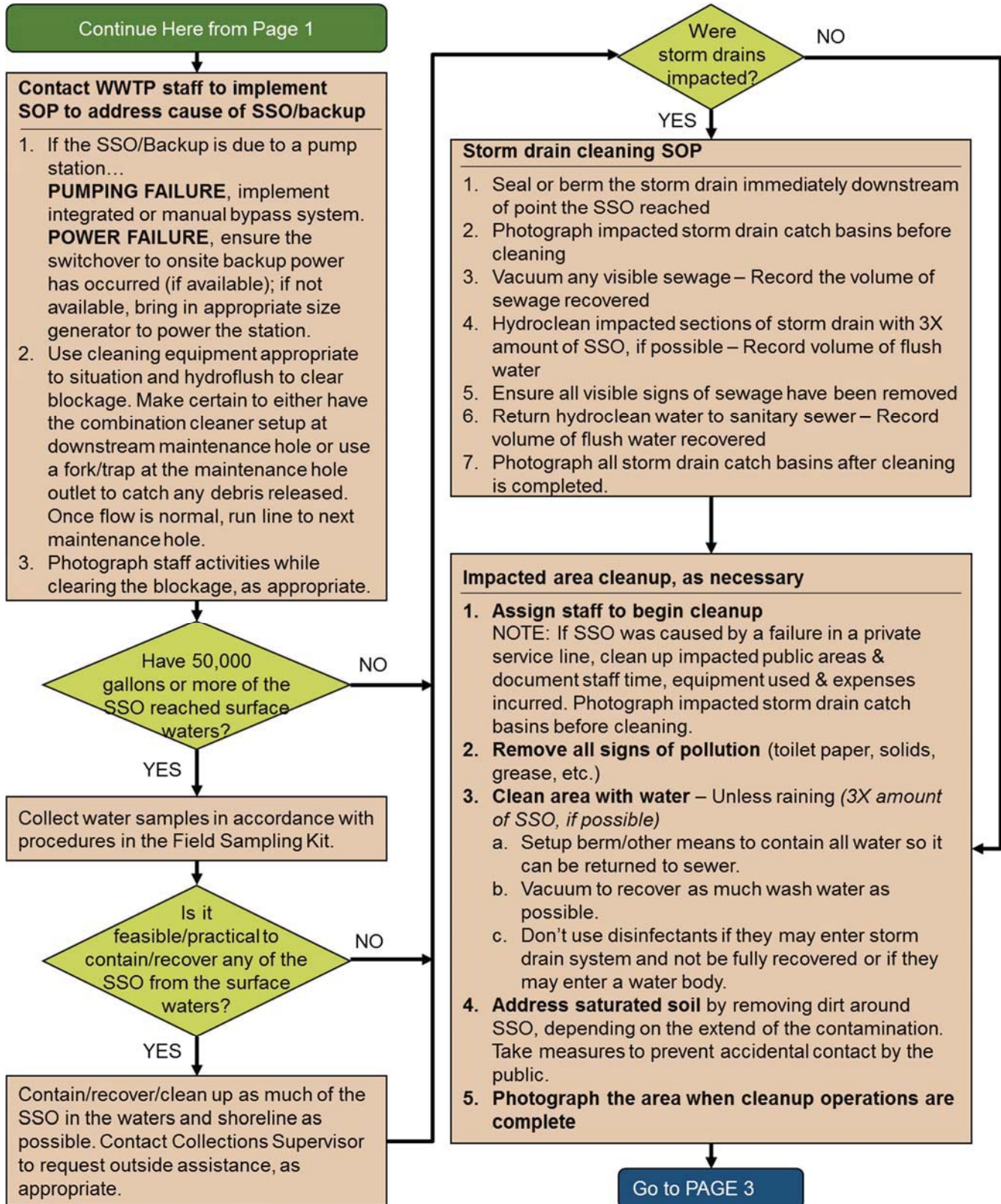



**Sanitary Sewer Overflow/Backup Response Flowchart**

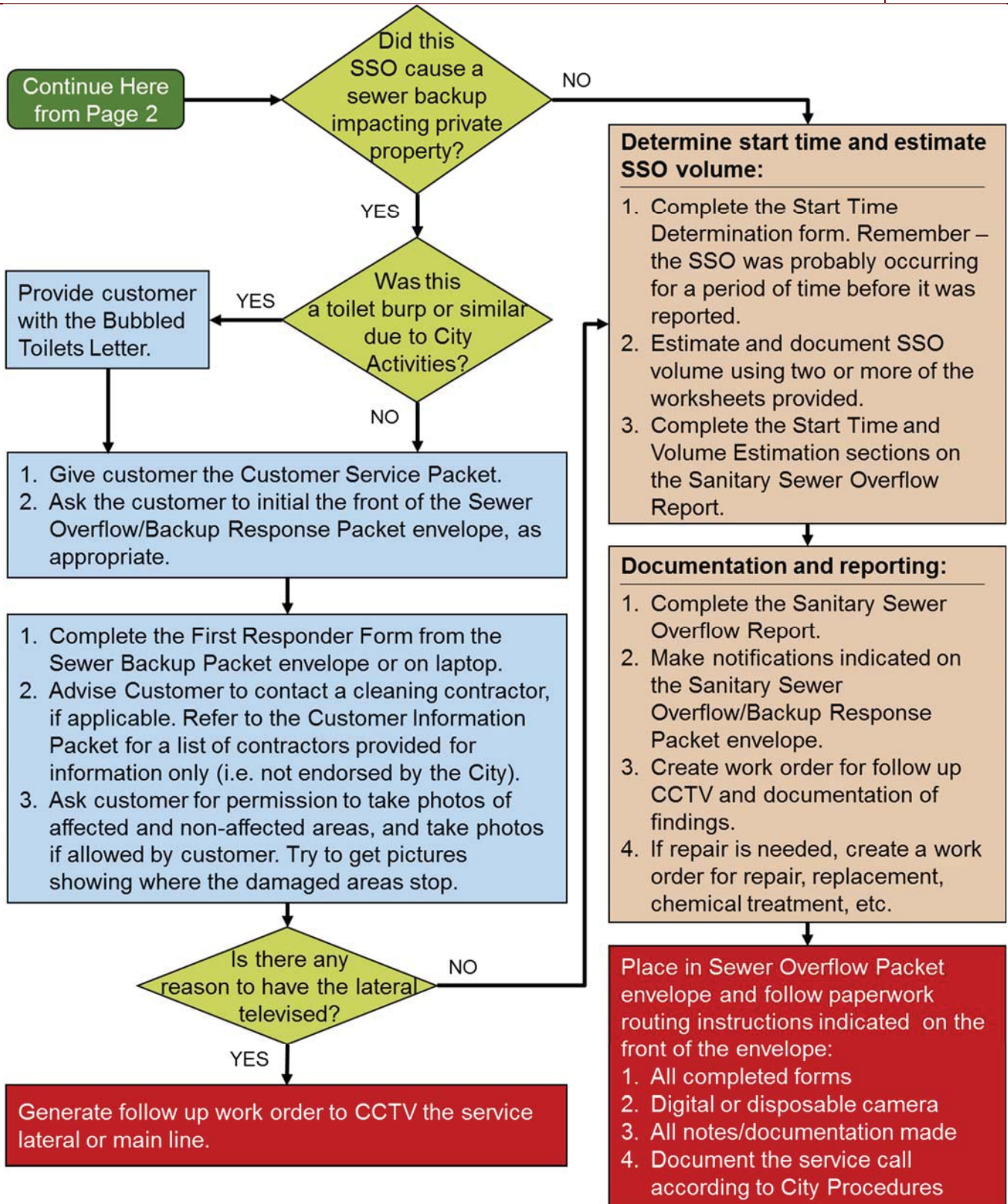

**Sanitary Sewer Overflow/Backup Response Packet  
Start Time Determination Form**

SSO Start Date: \_\_\_\_\_ Location: \_\_\_\_\_

Accurate start time determination is an essential part of SSO volume estimation. Depending on the flow rate, being even one minute off can have a huge impact on the volume estimation. Be as precise as possible. Do not round to quarter hour increments. Start time must be based on all available information (interviews with neighbors, emergency responders, etc.)

What time was the City notified of the SSO? \_\_\_\_\_  AM  PM

Who notified the City? \_\_\_\_\_

Did they indicate what time they noticed the SSO?  YES  NO If yes, what time? \_\_\_\_\_  AM  PM

Who at the City received the notification? \_\_\_\_\_

What time did the crew arrive at the site of the SSO? \_\_\_\_\_  AM  PM

Who was interviewed regarding the start time of the SSO? Include their name, contact information, and the statement they provided:

| Name  | Contact Information | Statement |
|-------|---------------------|-----------|
| _____ | _____               | _____     |
| _____ | _____               | _____     |
| _____ | _____               | _____     |
| _____ | _____               | _____     |

Describe in detail how you determined the start time for this particular SSO:

SSO Start Date: \_\_\_\_\_ SSO Start Time: \_\_\_\_\_  AM  PM

SSO End Date: \_\_\_\_\_ SSO End Time: \_\_\_\_\_  AM  PM

**SSO Duration: \_\_\_\_\_ minutes**

This form completed by:

Name: \_\_\_\_\_ Signature: \_\_\_\_\_

Job Title: \_\_\_\_\_ Date: \_\_\_\_\_



**Sanitary Sewer Overflow/Backup Response Packet  
Volume Estimation: Eyeball Estimation Method**

*Use this method only for small SSOs of less than 200 gallons.*

SSO Date: \_\_\_\_\_ Location: \_\_\_\_\_

- STEP 1: Position yourself so that you have a vantage point where you can see the entire SSO.
- STEP 2: Imagine one or more buckets or barrels of water tipped over. Depending on the size of the SSO, select a bucket or barrel size as a frame of reference. It may be necessary to use more than one bucket/barrel size.
- STEP 3: Estimate how many of each size bucket or barrel it would take to make an equivalent spill. Enter those numbers in Column A of the row in the table below that corresponds to the bucket/barrel sizes you are using as a frame of reference.
- STEP 4: Multiply the number in Column A by the multiplier in Column B. Enter the result in Column C.

|                                    | A                      | B               | C                              |
|------------------------------------|------------------------|-----------------|--------------------------------|
| Size of bucket(s) or barrel(s)     | How many of this size? | Multiplier      | Estimated SSO Volume (gallons) |
| 1 gallon water jug                 |                        | x 1 gallons     |                                |
| 5 gallon bucket                    |                        | x 5 gallons     |                                |
| 32 gallon trash can                |                        | x 32 gallons    |                                |
| 55 gallon drum                     |                        | x 55 gallons    |                                |
| Other: _____ gallons               |                        | x _____ gallons |                                |
| <b>Estimated Total SSO Volume:</b> |                        |                 |                                |

STEP 5: Is rainfall a factor in the SSO?  Yes  No  
 If yes, what volume of the observed spill volume do you estimate is rainfall? \_\_\_\_\_ gallons  
 If yes, describe how you determined the amount of rainfall in the observed spill?

STEP 6: Calculate the estimated SSO volume by subtracting the rainfall from the SSO volume:  
 \_\_\_\_\_ gallons – \_\_\_\_\_ gallons = \_\_\_\_\_ gallons  
 Estimated SSO Volume                  Rainfall                  **Total Estimated SSO Volume**

Do you believe that this method has estimated the entire SSO?  Yes  No  
 If no, you MUST use additional methods to estimate the entire SSO. If yes, it is advisable to use additional methods to support the estimation. Explain why you believe this method has/has not estimated the entire SSO:

This worksheet completed by:  
 Name: \_\_\_\_\_ Signature: \_\_\_\_\_  
 Job Title: \_\_\_\_\_ Date: \_\_\_\_\_

**Sanitary Sewer Overflow/Backup Response Packet  
Volume Estimation: Area/Volume Estimation Method**

*Note: Refer to form B-4b Page 3 for computation formulas and guides*

SSO Date: \_\_\_\_\_ Location: \_\_\_\_\_

STEP 1: Describe spill area surface: Asphalt Concrete Dirt Landscape Inside Building  
Other: \_\_\_\_\_

STEP 2: Draw/sketch the outline (footprint) of the spill. Then break the footprint down into recognizable shapes. Refer to the example on form B-4b Page 3.

STEP 3: Calculate the area of the footprint by completing the table below for each shape in Step 2. If two shapes overlap, select one of the two shapes and estimate the percentage of that shape that does not overlap. Enter that percentage in the % Not Overlapping column. This will ensure that the overlap area is only counted once. Refer to the example on form B-4b Page 3.

| Rectangles | Length | X | Width | X | % Not Overlapping* | = | Area            |
|------------|--------|---|-------|---|--------------------|---|-----------------|
|            | ft     | X | ft    | X | %                  | = | ft <sup>2</sup> |
|            | ft     | X | ft    | X | %                  | = | ft <sup>2</sup> |
|            | ft     | X | ft    | X | %                  | = | ft <sup>2</sup> |

| Triangles | Base | X | Height | Multiplier | X | % Not Overlapping* | = | Area            |
|-----------|------|---|--------|------------|---|--------------------|---|-----------------|
|           | ft   | X | ft     | ÷ 2        | X | %                  | = | ft <sup>2</sup> |
|           | ft   | X | ft     | ÷ 2        | X | %                  | = | ft <sup>2</sup> |
|           | ft   | X | ft     | ÷ 2        | X | %                  | = | ft <sup>2</sup> |

| Circles | π    | X | Radius | X | Radius | X | % Not Overlapping* | = | Area            |
|---------|------|---|--------|---|--------|---|--------------------|---|-----------------|
|         | 3.14 | X | ft     | X | ft     | X | %                  | = | ft <sup>2</sup> |
|         | 3.14 | X | ft     | X | ft     | X | %                  | = | ft <sup>2</sup> |
|         | 3.14 | X | ft     | X | ft     | X | %                  | = | ft <sup>2</sup> |

**Total Spill Area (sum of all three tables above): \_\_\_\_\_ ft<sup>2</sup>**

**Sanitary Sewer Overflow/Backup Response Packet  
Volume Estimation: Area/Volume Estimation Method**

STEP 4: Calculate the volume of the spill that **was NOT absorbed** into the ground. If the entire spill was absorbed, skip to Step 5.

- a. If spill is of varying depths, take several measurements at different depths and find the average.

$$\frac{\text{_____ inches}}{\text{sum of measurements}} \div \frac{\text{_____}}{\text{\# of measurements}} = \frac{\text{_____ inches}}{\text{average depth in inches}} \div 12 = \frac{\text{_____}}{\text{average depth in feet of ponded sewage}} \text{ feet}$$

- b. Calculate spill volume of ponded sewage in cubic feet by multiplying the Total Spill Area in Step 3 by the average depth calculated in Step 4a. Convert from cubic feet to gallons by multiplying by 7.48.

$$\frac{\text{_____}}{\text{spill area (Step 3)}} \text{ ft}^2 \times \frac{\text{_____}}{\text{average depth (Step 4a)}} \text{ ft} = \frac{\text{_____}}{\text{spill volume in cubic feet}} \text{ ft}^3 \times 7.48 \text{ gal} = \frac{\text{_____}}{\text{estimated volume of ponded sewage}} \text{ gallons}$$

STEP 5: Calculate the volume of the spill that **was absorbed** into the ground. If only a wet stain is observed, use the guidelines on B-4b Page 3 for the average depth. When estimating the volume that was absorbed, take into consideration:

- How long the sewage has been sitting
- The air temperature on the day of the SSO
- Soil type for the area (e.g., hard-packed clay vs. loose or gravelly soil)

When estimating the volume of the spill that was absorbed into the ground, it is also advisable to dig down far enough to reach dry soil and take the depth of the wet soil into consideration.

Estimated volume that was absorbed into the soil: \_\_\_\_\_ gallons

Explain how this estimation was determined:

STEP 6: Add the volume not absorbed (Step 4) plus the volume absorbed (Step 5) to get the total estimated volume:

$$\frac{\text{_____}}{\text{volume not absorbed}} \text{ gallons} + \frac{\text{_____}}{\text{volume absorbed}} \text{ gallons} = \frac{\text{_____}}{\text{Total Estimated Spill Volume}} \text{ gallons}$$

Do you believe that this method has estimated the entire SSO?  Yes  No

If no, you MUST use additional methods to estimate the entire SSO. If yes, it is advisable to use additional methods to support the estimation. Explain why you believe this method has/has not estimated the entire SSO:

This worksheet completed by:

Name: \_\_\_\_\_  
Job Title: \_\_\_\_\_

Signature: \_\_\_\_\_  
Date: \_\_\_\_\_

**Miscellaneous Computations**

|   |  |
|---|--|
| To convert inches to feet   | Divide the inches by 12 or use the chart on the bottom right of this page.   |
| Volume of one cubic foot  | 7.48 gallons of water  |
| <b>Area:</b><br>Two-dimensional measurement represented in square feet    | Square/rectangle: Area = Length x Width<br>Circle: Area = $\pi r^2$ (where $\pi \approx 3.14$ and $r = \text{radius} = \frac{1}{2}$ diameter)<br>Triangle: Area = $\frac{1}{2}$ (Base x Height)  |
| <b>Volume:</b><br>Three-dimensional measurement represented in cubic feet | Rectangle/square footprint: Volume = Length x Width x Depth<br>Circle footprint (cylinder): Volume = $\pi r^2 \times \text{Depth}$<br>(where $\pi \approx 3.14$ and $r = \text{radius} = \frac{1}{2}$ diameter)<br>Triangle footprint: Volume = $\frac{1}{2}$ (Base x Height) x Depth  |
| <b>Depth:</b><br>Contained or "Ponded" sewage                             | Measure actual depth of standing sewage whenever possible. When depth varies, measure several representative sample points and determine the average. Add the depth of the sample points and then divide that total by the number of sample points.<br><br>If the depth is not measurable because it is only a wet stain, consider using the following estimated depths: <ul style="list-style-type: none"> <li>• Depth of a wet stain on concrete surface: 0.0026' (1/32")</li> <li>• Depth of a wet stain on asphalt surface: 0.0013' (1/64")</li> </ul> |

**Example of how to draw/sketch the outline (footprint) of the spill for Step 2:**

1. Sketch the outline of the spill (black line).
2. Break the sketch down into recognizable shapes (circles, squares, etc.) as well as you can.

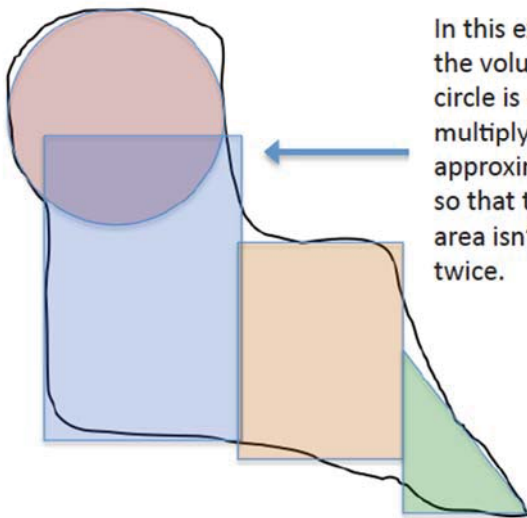

In this example, after the volume of the circle is determined, multiply it by approximately 65% so that the overlap area isn't counted twice.

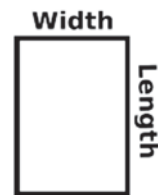

| Convert Inches to Feet |       |
|------------------------|-------|
| Inches                 | Feet  |
| 1/8"                   | 0.01' |
| 1/4"                   | 0.02' |
| 3/8"                   | 0.04' |
| 1/2"                   | 0.04' |
| 5/8"                   | 0.06' |
| 3/4"                   | 0.07' |
| 7/8"                   | 0.08' |
| 1"                     | 0.08' |
| 2"                     | 0.17' |
| 3"                     | 0.25' |
| 4"                     | 0.33' |
| 5"                     | 0.42' |
| 6"                     | 0.50' |
| 7"                     | 0.58' |
| 8"                     | 0.67' |
| 9"                     | 0.75' |
| 10"                    | 0.83' |
| 11"                    | 0.92' |
| 12"                    | 1.00' |



**Sanitary Sewer Overflow/Backup Response Packet  
Volume Estimation: Upstream Lateral Connections Method**

SSO Date: \_\_\_\_\_ Location: \_\_\_\_\_

STEP 1: Determine the number of Equivalent Dwelling Units (EDUs) for this SSO: \_\_\_\_\_ EDUs  
NOTE: A single-family residential home = 1 EDU. For commercial buildings, refer to agency documentation.

STEP 2: This volume estimation method utilizes daily usage data based on flow rate studies of several jurisdictions in California. Column A shows how an average daily of usage of 180 gallons per day is distributed during each 6-hour period. Adjust the table as necessary to accurately represent the actual data.

Complete Column E by entering the number of minutes the SSO was active during each 6-hour time period. Multiply column D times Column E to calculate the gallons spilled during each time period. Add the numbers in Column F together for the Total Estimated SSO Volume per EDU.

| Time Period                                | Flow Rate Per EDU  |                  |                          |                             | SSO                                  |                                    |
|--|--------------------|------------------|--------------------------|-----------------------------|--------------------------------------|------------------------------------|
|  | A                  | B                | C                        | D                           | E                                    | F                                  |
|  | Gallons per Period | Hours per period | A ÷ B = Gallons per Hour | C ÷ 60 = Gallons per Minute | Minutes SSO was active during period | D × E = Gallons spilled per period |
| 6am-noon                                   | 72                 | 6                | 12                       | 0.20                        |                                      |                                    |
| noon-6pm                                   | 36                 | 6                | 6                        | 0.10                        |                                      |                                    |
| 6pm-midnight                               | 54                 | 6                | 9                        | 0.15                        |                                      |                                    |
| midnight-6am                               | 18                 | 6                | 3                        | 0.05                        |                                      |                                    |
| <b>Total Estimated SSO Volume per EDU:</b> |                    |                  |                          |                             |                                      |                                    |

STEP 3: Multiply the Estimated SSO Volume per EDU from Step 2 by the number of EDUs from Step 1.  

$$\frac{\text{gallons}}{\text{Volume per EDU}} \times \frac{\text{# of EDUs}}{\text{# of EDUs}} = \frac{\text{gallons}}{\text{Estimated SSO Volume}}$$

STEP 4: Adjust SSO volume as necessary considering other factors, such as activity that would cause a fluctuating flow rate (doing laundry, taking showers, etc.). Explain rationale below and indicate adjusted SSO estimate (attach a separate page if necessary):

Estimated SSO Volume: \_\_\_\_\_ gallons

Do you believe that this method has estimated the entire SSO?  Yes  No

If no, you MUST use additional methods to estimate the entire SSO. If yes, it is advisable to use additional methods to support the estimation. Explain why you believe this method has/has not estimated the entire SSO:

This worksheet completed by:

Name: \_\_\_\_\_ Signature: \_\_\_\_\_  
 Job Title: \_\_\_\_\_ Date: \_\_\_\_\_

Sanitary Sewer Overflow/Backup Response Packet  
Volume Estimation: Manhole Overflow Flowrate



City of San Diego  
Metropolitan Wastewater Department

Reference Sheet for Estimating Sewer Spills  
from Overflowing Sewer Manholes

All estimates are calculated in gallons per minute (gpm)

Wastewater Collection Division  
(619) 654-4160



5 gpm



25 gpm



50 gpm



100 gpm



150 gpm



200 gpm



225 gpm



250 gpm



275 gpm

All photos were taken during a demonstration using metered water from a hydrant in cooperation with the City of San Diego's Water Department.

**Sanitary Sewer Overflow/Backup Response Packet  
Volume Estimation: Manhole Overflow Flowrate**

SSO Date: \_\_\_\_\_ Location: \_\_\_\_\_

- STEP 1: Position yourself so you can clearly see the overflowing maintenance hole.
- STEP 2: Use the reference sheet on the previous page to estimate the flowrate at the maintenance hole.
- STEP 3: Using the establish start time, determine the duration of the SSO in minutes.
- STEP 4: Multiply the flowrate shown on the reference sheet for the corresponding photo by the number of minutes the SSO occurred. Use multiple flowrates and durations at that flowrate if the overflow rate is not constant during the SSO.

| Maintenance Hole Overflow Flowrate (gpm) | x | Duration of SSO (minutes) | Estimated SSO Volume (gallons) |
|--|---|---------------------------|--------------------------------|
|  | x |                           |                                |
|  | x |                           |                                |
|  | x |                           |                                |
|  | x |                           |                                |
|  | x |                           |                                |
| <b>Estimated Total SSO Volume:</b>       |   |                           |                                |

Do you believe that this method has estimated the entire SSO? Yes No

If no, you MUST use additional methods to estimate the entire SSO. If yes, it is advisable to use additional methods to support the estimation. Explain why you believe this method has/has not estimated the entire SSO:

This worksheet completed by:

Name: \_\_\_\_\_ Signature: \_\_\_\_\_  
 Job Title: \_\_\_\_\_ Date: \_\_\_\_\_

**Sanitary Sewer Overflow/Backup Response Packet**  
**Sanitary Sewer Overflow Report**

**INSTRUCTIONS: Complete all items EXCEPT those that are shaded gray**

SSO Category (check one):

- Category 1: Discharge of untreated or partially treated wastewater of any volume resulting from a sanitary sewer system failure or flow condition that either (1) Reaches surface water and/or drainage channel tributary to a surface water; OR (2) Reached a Municipal Separate Storm Sewer System (MS4) and was not fisure of lly captured and returned to the sanitary sewer system or otherwise captured and disposed of properly.
- Category 2: Discharge of untreated or partially treated wastewater greater than or equal to 1,000 gallons resulting from a sanitary sewer system failure or flow condition that either (1) Does not reach surface water, a drainage channel, or an MS4, OR (2) The entire SSO discharged to the storm drain system was fully recovered and disposed of properly.
- Category 3: All other discharges of untreated or partially treated wastewater resulting from a sanitary sewer system failure or flow condition
- Spill from Private Lateral (specify):  Single Family Home  Multi-Family Home  High Density Residential (5+ units)  
 Food Service Establishment (FSE)  Mixed Use Property  Industrial Property  Commercial Property  
 Public quasi-public institution (hospital, schools, fire department, etc.)

**IMMEDIATE NOTIFICATION: For a Category 1 SSO ≥1,000 gallons reaching surface waters, CalOES must be contacted within 2 hours at (800) 852-7550.**

**A. SSO LOCATION**

|                         |                           |           |
|-------------------------|---------------------------|-----------|
| SSO Location Name:      |                           |           |
| Latitude Coordinates:   | Longitude Coordinates:    |           |
| Street Name and Number: |                           |           |
| Nearest Cross Street:   | City:                     | Zip Code: |
| County:                 | SSO Location Description: |           |

**B. SSO DESCRIPTION (Complete Volume Estimation Worksheets and/or refer to Field Guide as needed for estimations.)**

|  |   |   |
|--|---|---|
| SSO Appearance Point (check one or more): <input type="checkbox"/> Force Main <input type="checkbox"/> Gravity Mainline <input type="checkbox"/> Manhole   |   |   |
| <input type="checkbox"/> Lateral Cleanout (Public)   | <input type="checkbox"/> Lateral Cleanout (Private)       | <input type="checkbox"/> Inside Building or Structure <input type="checkbox"/> Pump Station                                 |
| <input type="checkbox"/> Lateral (Private)   | <input type="checkbox"/> Service Lateral or Lower Lateral | <input type="checkbox"/> Other Sewer System Structure (specify):  |
| Were there multiple spill appearance points? <input type="checkbox"/> No <input type="checkbox"/> Yes, number of appearance points:  |   |   |
| Did the SSO reach a drainage channel and/or surface water? <input type="checkbox"/> Yes (Category 1) <input type="checkbox"/> No   |   |   |
| If the SSO reached a storm sewer, was it fully captured and returned to the Sanitary Sewer? <input type="checkbox"/> Yes <input type="checkbox"/> No (Category 1)  |   |   |
| Was this spill from a private lateral? <input type="checkbox"/> Yes <input type="checkbox"/> No If YES, name of responsible party:   |   |   |
| Final Spill Destination: <input type="checkbox"/> Surface waters other than ocean <input type="checkbox"/> Drainage channel <input type="checkbox"/> Building/structure  |   |   |
| <input type="checkbox"/> Separate Storm drain  | <input type="checkbox"/> Combined storm drain             | <input type="checkbox"/> Paved surface <input type="checkbox"/> Unpaved surface <input type="checkbox"/> Street/curb/gutter |
| <input type="checkbox"/> Other:  |   |   |
| *Provide name(s) of affected drainage channels, beach, etc.:   |   |   |
| Total Estimated SSO volume (in gallons – 1,000gal or more = Category 1):   |   | gallons   |
| Est. volume that reached a separate storm drain that flows to a surface water body:  | gal   | Recovered: gal  |
| Est. volume that reached a drainage channel that flows to a surface water body:  | gal   | Recovered: gal  |
| Est. volume discharged directly to a surface water body:   | gal   | Recovered: gal  |
| Est. volume discharged to land:  | gal   | Recovered: gal  |
| Calc. Methods: <input type="checkbox"/> Eyeball <input type="checkbox"/> Photo Comparison <input type="checkbox"/> Upstream Lat. Connections <input type="checkbox"/> Area/Volume (include sketch/photo with dimensions) |   |   |
| <input type="checkbox"/> Other (describe):   |   |   |

**C. SSO OCCURRING TIME (complete Start Time Determination Form and then complete information below)**

|   |                                  |
|---|----------------------------------|
| Estimated SSO start date:                         | Estimated SSO start time:        |
| Date SSO reported to sewer crew:                  | Time SSO reported to sewer crew: |
| Date sewer crew arrived:                          | Time sewer crew arrived:         |
| Who was interviewed to help determine start time? |                                  |
| Estimated SSO end date:                           | Estimated SSO end time:          |

\* If multiple appearance points, use the GPS coordinates for the location of the SSO appearance point closest to the failure point/blockage.



**Sanitary Sewer Overflow/Backup Response Packet  
Sanitary Sewer Overflow Report**

**D. CAUSE OF SSO**

Where did failure occur? (Check all that apply):  Air Relief or Blow-Off Valve  Force Main  Gravity Mainline  Siphon  
 Lower Lateral (public)  Manhole  Pump Station (specify):  Controls  Mechanical  Power  
 Lateral (private)  Service Lateral or Lower Lateral  Other:

SSO cause (check all that apply):  Air Relief or Blow-Off Valve Failure  Construction Diversion Failure  CS Maintenance  
 Damage by others  Debris (specify):  From Construction  From Lateral  General  Rags  Flow Exceeded Capacity  
 FOG (Fats, oil, grease)  Inappropriate Discharge  Natural Disaster  Operator Error  Root Intrusion  
 Pipe Structural Problem/Failure  Pipe Structural Problem/Failure (Installation)  Rainfall Exceeded Design  
 Pump Station Failure (specify):  Controls  Mechanical  Power  Roots  Siphon Failure  Vandalism  
 Surcharged Pipe  Non - Dispersible Wipes  Other (specify):

Diameter (in inches) of pipe at point of blockage/spill cause (if applicable):

Sewer pipe material at point of blockage/spill cause (if applicable):

Estimated age of sewer asset at the point of blockage or failure (if applicable):

Description of terrain surrounding point of blockage/spill cause:  Flat  Mixed  Steep

**E. SSO RESPONSE**

SSO response activities (check all that apply):  Cleaned-Up  Mitigated Effects of Spill  Contained All or Portion of Spill  
 Restored Flow  Returned All Spill to Sanitary Sewer System  Returned Portion of Spill to Sanitary Sewer System  
 Property Owner Notified  Other Enforcement Agency Notified (specify)  Other (specify):

SSO response completed (date & time):

Visual inspection result of impacted waters (if applicable):

Any fish killed?  Yes  No Any ongoing investigation?  Yes  No

Were health warnings posted?  Yes  No

Were samples of impacted waters collected?  Yes  No

If YES, select the analyses:  DO  Ammonia  Bacteria  pH  Temperature  Other:

Recommended corrective actions: (check all that apply and provide detail)

- Add sewer to preventive maintenance program  Adjust schedule/method of preventive maintenance
- Enforcement action against FOG source  Inspect sewer using CCTV to determine cause
- Plan rehabilitation or replacement of sewer  Repair facilities or replace defect
- Remove roots  Spot repair
- Other (specify):

What major equipment was used in the response?

List all agency personnel involved in the response including name, title and their role in the response:

**F. NOTES**

**G. NOTIFICATION DETAILS: Enter details if applicable**

CalOES contacted on (Date and Time):

Spoke to:

CalOES Control Number:

This form prepared by: NAME: TITLE: DATE:

This form reviewed by: NAME: TITLE: DATE:

Place completed form in Sewer Backup Envelope and follow routing instructions.

**Sanitary Sewer Overflow/Backup Response Packet  
Lateral CCTV Report**

**B-5**

**Document results of Lateral CCTV inspection in Lucity work order or on form B-4 if after hours.**

**Sanitary Sewer Overflow/Backup Response Packet  
Bubbled Toilets Letter**

ENGLISH

Dear City of Davis Customer,

Thank you for informing us that your toilet bubbled while our crews were working in proximity of your property. We apologize for the inconvenience and hope that this letter will answer some of your questions about bubbling toilets.

**1. Is this a health risk?**

The water that came out of your toilet is potable water from the toilet bowl. Unless your toilet was in use when this occurred, this water is no different than that encountered while cleaning your toilet.

**2. What is the City doing in the street?**

In order to insure reliable sewer service, the City inspects, cleans, and repairs its sewer system on a continuous basis.

**3. How does sewer cleaning cause my toilet to bubble?**

Typical industry cleaning equipment uses high-pressure water to clean sewers. The first step is to use the high-pressure water jets to propel the hose and cleaning nozzle upstream as far as 800 feet. During this process, air within the main pipe is displaced and sometimes goes up the private lateral pipe and releases through the toilet. This can also happen during the cleaning phase, when high-pressure water is pulled downstream to the cleaning truck.

**4. What causes the air to come from my toilet?**

Over the years, City crews have found that the bubbling of toilets have many causes, some of which are:

- Obstructed vent pipes;
- Vent pipes that are positioned too far from the toilet;
- Lateral pipes that may be in use as the crew is cleaning (e.g. draining washing machine, draining bathtub, etc.);
- Lateral pipes that may have obstructions that are causing them to hold water (e.g. roots, grease, etc.).

**5. What does City staff do, once informed of a bubbling toilet?**

Once notified of a bubbling toilet, the crew leader explains to the customer what has happened, and checks to see if there is a clean-out in the customer's yard that could be opened in the future during cleaning. The crew leader then makes notes and completes paperwork that puts the address on the City's computerized notification list. In the future, crews will notice that this address was "bubbled" at one time, and, before commencing the cleaning, they will notify the occupant of the possibility of bubbling toilets. In the event the occupant is not present when the cleaning begins, the crews will attempt to open clean-outs and/or lower water pressure to avoid bubbling.

**6. What can I do to prevent my toilet from bubbling?**

When a sewer begins to drain slowly, it may be a sign that it needs to be cleaned or repaired. Trees and shrubs may have root structures that are entering the lateral pipe. The homeowner needs to make sure to have a clean-out for accessing the line. It is the homeowner's responsibility to keep the sewer lateral pipe in good working condition.

It is always a good idea to keep the toilet lid down when not in use, and not install carpets in the bathroom unless they can be easily removed and cleaned. For more information, please call the Collections Supervisor at (530) 757-5686.

Sincerely,

City of Davis

**Paquete de respuesta ante desborde/obstrucción del alcantarillado sanitario**  
**Carta sobre inodoros que burbujan**

Estimado cliente de la ciudad de Davis:

Gracias por informarnos que su inodoro burbujeó mientras nuestros equipos trabajaban en las cercanías de su propiedad. Pedimos disculpas por las molestias y esperamos que esta carta responda algunas de sus preguntas sobre los inodoros que burbujan.

**1. ¿Es un riesgo para la salud?**

El agua que salió de su inodoro es agua potable de la taza del inodoro. A menos que el inodoro haya estado en uso cuando esto sucedió, esta agua no es diferente a la que se encuentra cuando limpia el inodoro.

**2. ¿Qué realiza la Ciudad en la calle?**

A fin de asegurar un servicio de alcantarillado confiable, la Ciudad inspecciona, limpia y repara el sistema de alcantarillado de manera continua.

**3. ¿De qué manera la limpieza del alcantarillado provoca que mi inodoro burbujee?**

El equipo industrial típico de limpieza utiliza agua a alta presión para limpiar el alcantarillado. El primer paso es utilizar el chorro de agua a alta presión para impulsar la manguera y la boquilla de limpieza contracorriente con un alcance de hasta 243,8 m (800 pies). Durante este proceso, el aire dentro de la tubería principal se desplaza y algunas veces sube por la tubería lateral privada y se libera a través del inodoro. Esto también puede ocurrir durante la fase de limpieza, cuando el agua a alta presión se arrastra aguas abajo hasta el camión de limpieza.

**4. ¿Qué provoca que el aire se libere por mi inodoro?**

A través de los años, los equipos de la Ciudad descubrieron que el burbujeo de los inodoros ocurre debido a varias causas, entre las cuales encontramos las siguientes:

- tubos de ventilación obstruidos;
- tubos de ventilación que se colocan demasiado lejos del inodoro;
- tuberías laterales que pueden estar en uso mientras el equipo realiza la limpieza (por ejemplo, el drenaje de la lavadora, el drenaje de la bañera, etc.);
- tuberías laterales que pueden tener obstrucciones que hacen contener el agua (por ejemplo, raíces, grasa, etc.).

**5. ¿Qué hace el personal de la Ciudad una vez que se le informa de un inodoro que burbujea?**

Una vez que se notifica un inodoro que burbujea, el líder del equipo le explica al cliente lo que ha sucedido y comprueba si hay un registro de alcantarillado en el patio del cliente que podría abrirse en limpiezas futuras. Luego, el líder del equipo toma notas y completa documentación para incluir la dirección en la lista automatizada de notificaciones de la Ciudad. En el futuro, los equipos notarán que en esta dirección hubo "burbujeos" en un momento y, antes de comenzar la limpieza, notificará al ocupante acerca de la posibilidad de que burbujeen los inodoros. En caso de que el ocupante no esté presente cuando la limpieza se inicia, los equipos intentarán abrir los registros de alcantarillado y bajar la presión del agua para evitar el burbujeo.

**6. ¿Qué puedo hacer para evitar que mi inodoro burbujee?**

Cuando un alcantarillado comienza a drenar lentamente, puede ser un signo de que es necesario limpiarlo o repararlo. Los árboles y arbustos pueden tener estructuras de raíz que entren en la tubería lateral. El propietario debe asegurarse de tener un registro de alcantarillado para acceder a la línea. Es responsabilidad del dueño de casa mantener la tubería lateral de la alcantarilla en buen funcionamiento.

Siempre es una buena idea mantener la tapa del inodoro baja cuando no está en uso y no instalar alfombras en el baño a menos que puedan quitarse y limpiarse con facilidad. Para obtener más información, comuníquese con el Supervisor de Obras Públicas al (530) 757-5686.

Atentamente,

Ciudad de Davis



**Sanitary Sewer Overflow/Backup Response Packet  
First Responder Form**

Fill out this form as completely as possible.  
Ask customer if you may enter the home. If so, take photos of all damaged and undamaged areas.

|  |  |   |
|--|--|---|
| PERSON COMPLETING THIS FORM:   |  | PHONE:  |
| Name: _____  |  | DATE:   |
| Title: _____   |  | TIME:   |
| TIME STAFF ARRIVED ON-SITE:  |  |   |
| DOES THE CUSTOMER WANT THE CITY TO CALL A CLEANING CONTRACTOR? <input type="checkbox"/> Yes <input type="checkbox"/> No<br>IF NO, complete the Declination of Sewage Cleaning Services form. |  |   |
| DID CUSTOMER CALL CLEANING CONTRACTOR? <input type="checkbox"/> Yes <input type="checkbox"/> No<br>If YES, name of contractor:   |  |   |
| RESIDENT NAME:<br><input type="checkbox"/> Owner<br><input type="checkbox"/> Renter  | IF RENT,<br>PROPERTY MANAGER(S):<br>OWNER:           |   |
| STREET ADDRESS:<br>CITY, STATE AND ZIP:<br>PHONE:  | STREET ADDRESS:<br>CITY, STATE AND ZIP:<br>PHONE:    |   |
| Is nearest upstream manhole visibly higher than the drain/fixture that overflowed? <input type="checkbox"/> Yes <input type="checkbox"/> No  |  |   |
| # OF PEOPLE LIVING AT RESIDENCE:   |  |   |
| Approximate Age of Home:   | # of Bathrooms:                                      | # of Rooms Affected:  |
| Approximate Amount of Spill (gallons):   | Approximate Time Sewage Has Been Sitting (hrs/days): |   |
| Numbers of Photographs or Videos Taken:<br><input type="checkbox"/> Photographs <input type="checkbox"/> Video   | Where are photos/video stored?                       |   |
| Does property have a Property Line Cleanout or BPD?  |  | <input type="checkbox"/> YES <input type="checkbox"/> NO <input type="checkbox"/> Unknown |
| If yes, was the Property Line Cleanout/BPD operational at the time of the overflow?  |  | <input type="checkbox"/> YES <input type="checkbox"/> NO <input type="checkbox"/> Unknown |
| Have there ever been any previous spills at this location?   |  | <input type="checkbox"/> YES <input type="checkbox"/> NO <input type="checkbox"/> Unknown |
| Has the resident had any plumbing work done recently?<br><i>If YES, please describe:</i>   |  | <input type="checkbox"/> YES <input type="checkbox"/> NO                                  |

**GO TO PAGE 2**

**Sanitary Sewer Overflow/Backup Response Packet  
First Responder Form**

**LIVABILITY ASSESSMENT**

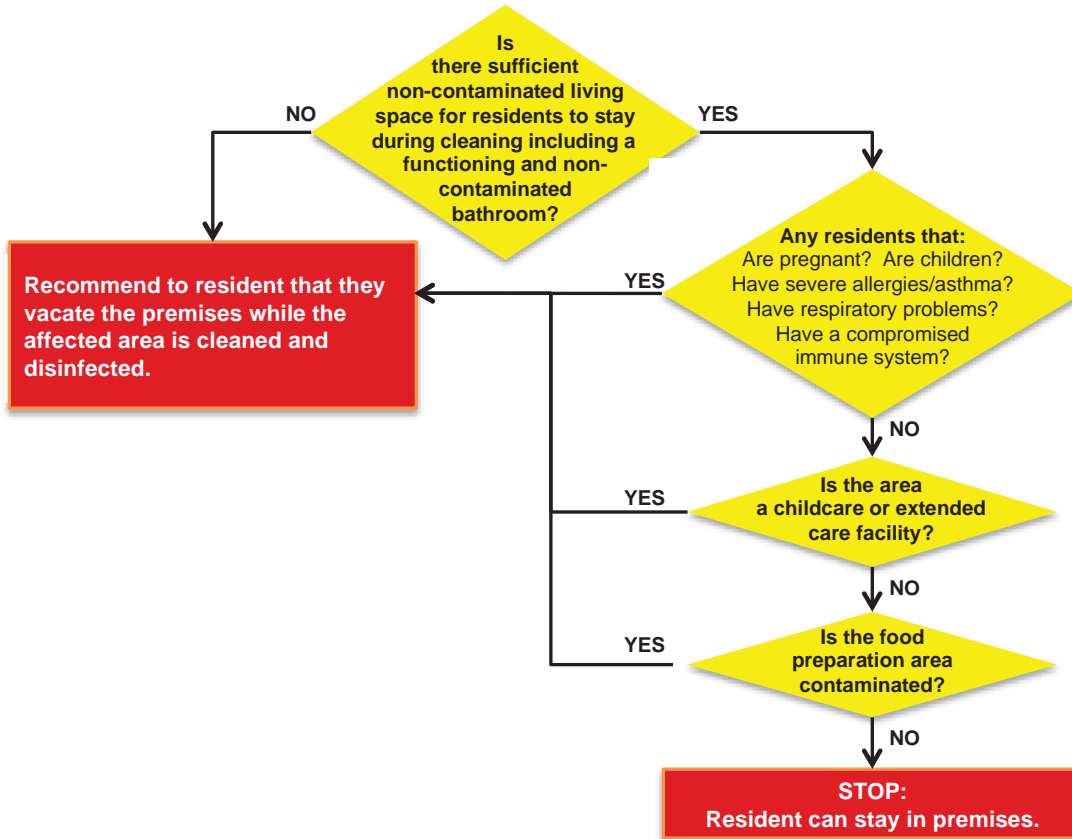

**SANITARY SEWER LINE BLOCKAGE LOCATION**

**PLEASE CHECK THE BOXES THAT DESCRIBE YOUR OBSERVATIONS:**

- |                                       |                                       |
|---------------------------------------|---------------------------------------|
| Customer Cleanout Was:                | Public Cleanout was:                  |
| <input type="checkbox"/> Non-Existent | <input type="checkbox"/> Non-Existent |
| <input type="checkbox"/> Full         | <input type="checkbox"/> Full         |
| <input type="checkbox"/> Empty        | <input type="checkbox"/> Empty        |

**Recommended Follow-Up Action(s):**

**On the diagram below, indicate the location of the sewer line and where the problem occurred.**



Did sewage go under buildings?  Yes  No  Unsure

Place completed form in Sewer Backup Envelope and follow routing instructions

**Sanitary Sewer Overflow/Backup Response Packet  
Claims Submittal Checklist**

**Complete this form if there is a Sanitary Sewer Backup into/onto Private Property**

## Collections Supervisor

1. Complete the following information:

Title: \_\_\_\_\_  
Name: \_\_\_\_\_  
Phone: \_\_\_\_\_  
Today's Date: \_\_\_\_\_

2. Copy the items listed below and retain originals for internal archiving purposes.

3. Place the copies in the Backup Response Envelope and forward to Risk Management:

- Form B-2: Start Time Determination Form
- Form B-3: Volume Estimation Forms (a, b and/or c)
- Form B-4: Sanitary Sewer Overflow Report
- Form B-5: Lateral CCTV Report
- Form B-7: First Responder Form
- Form B-8: Claims Submittal Checklist (*this form*)
- All photos taken: Check here if digital photographs will be forwarded separately
- Copies of Work Orders related to this claim
- Any other information you feel is important in this claim

4. Go to Regulatory Notifications Packet and make all appropriate notifications.

5. Complete Form BP-9: Collection System Failure Analysis

## Risk Management

1. Verify claims packet is complete.
2. Review incident reports, claim form and other incident information.
3. Communicate with claimant as appropriate.
4. Process claim in accordance with City policy.

**Sanitary Sewer Overflow/Backup Response Packet  
Collection System Failure Analysis**

**To be completed by the Collections Supervisor**

*NOTE: The information contained on this form may be confidential.*

|  |       |                     |      |
|--|-------|---------------------|------|
| Incident Report #  |       | Prepared By         |      |
| <b>SSO/Backup Information</b>  |       |                     |      |
| Event Date/Time  |       | Address             |      |
| Volume Spilled   |       | Volume Recovered    |      |
| Cause  |       |                     |      |
| <b>Summary of Historical SSOs/Backups/Service Calls/Other Problems</b> |       |                     |      |
| Date   | Cause | Date Last Cleaned   | Crew |
|  |       |                     |      |
|  |       |                     |      |
|  |       |                     |      |
| Records Reviewed By:   |       | Record Review Date: |      |
| <b>Summary of CCTV Information</b>                                     |       |                     |      |
| CCTV Inspection Date   |       | Tape Name/Number    |      |
| CCTV Tape Reviewed By  |       | CCTV Review Date    |      |
| Observations   |       |                     |      |



**Sanitary Sewer Overflow/Backup Response Packet  
Collection System Failure Analysis**

**Recommendations**

| ✓ | Type                                      | Specific Actions | Who is Responsible? | Completion Deadline | Who Will Verify Completion? |
|---|---|------------------|---------------------|---------------------|-----------------------------|
|   | No Changes or Repairs Required            | n/a              | n/a                 | n/a                 | n/a                         |
|   | Repair(s)                                 |                  |                     |                     |                             |
|   | Construction                              |                  |                     |                     |                             |
|   | Capital Improvement(s)                    |                  |                     |                     |                             |
|   | Change(s) to Maintenance Procedures       |                  |                     |                     |                             |
|   | Change(s) to Overflow Response Procedures |                  |                     |                     |                             |
|   | Training                                  |                  |                     |                     |                             |
|   | Misc.                                     |                  |                     |                     |                             |

Comments/Notes:

Review Date:

**City of Davis**  
**Overflow Emergency Response Plan**

**Customer Service Packet**

| <u>Form</u>                       | <u>Form Number</u> |
|-----------------------------------|--------------------|
| Customer Information Letter ..... | CS-1               |
| Claim Form.....                   | CS-2               |
| Sewer Spill Reference Guide.....  | pamphlet           |

**Instructions:**

1. Review the Customer Information letter to determine actions that need to be taken immediately.
2. See the Customer Information letter for information about filing a claim.
3. Review the Sewer Spill Reference Guide pamphlet.

**If you have any questions, contact:**

- Regarding sewer issues: Collections Supervisor (530) 757-5686
- Regarding claim issues: Risk Management Office (530) 757-5644

**This packet provided by:** \_\_\_\_\_

**Phone:** \_\_\_\_\_

**Paquete de servicio al cliente**

| <u>Formulario</u>   | <u>Número de formulario</u> |
|---|-----------------------------|
| Carta de información para el cliente .....                      | CS-1                        |
| Formulario de reclamación .....                                 | CS-2                        |
| Guía de referencia en caso de desborde del alcantarillado ..... | folleto                     |

**Instrucciones:**

1. Revise la carta de información para el cliente para determinar qué medidas deben tomarse inmediatamente.
2. Consulte la carta de información para el cliente sobre cómo presentar una reclamación.
3. Revise el folleto de la Guía de referencia en caso de desborde del alcantarillado.

**Si tiene alguna consulta, comuníquese con las siguientes entidades:**

- Para los problemas relacionados con el alcantarillado, comuníquese con el Supervisor de Obras Públicas: (530) 757-5686
- Para los problemas relacionados con las reclamaciones, comuníquese con la Oficina de gestión de riesgos: (530) 757-5644

**Este paquete lo proporciona:** \_\_\_\_\_

**Teléfono:** \_\_\_\_\_

**Sanitary Sewer Overflow/Backup Response Packet**  
**Customer Information Regarding Sewer Backup Claims**

Dear Resident:

We recognize that sewer back flow incidents can be stressful. The City has prepared this brief set of instructions to help you minimize the impact of the loss by responding promptly to the situation.

The City is not responsible for cleanup charges or damages caused by blockages in the property owner's sewer line or caused by code violations. Regardless of whether you or the City is responsible for the loss, it is up to you to arrange for the repair of your property. If the City is responsible for the damages, you may choose to have the restoration company invoice the City directly for the clean-up.

You or the property owner should immediately contact a firm for clean-up of the affected areas. If you do not know of a company to call for service, the following 24-hour emergency restoration companies are available to respond: \*

| Restoration Company           | Location                                       | Contact      |
|-------------------------------|--|--------------|
| SERVPRO                       | PO Box 2263 Davis CA 95617                     | 530-756-1414 |
| Restoration Management Co.    | 1804 Enterprise Blvd. West Sacramento CA 95691 | 800-400-5058 |
| COIT Cleaning and Restoration | 3499 Business Dr. Sacramento CA 95820          | 916-731-7090 |

\* This list is provided as a resource only. The City does not require or endorse the use of any of these firms. This list is not to be construed as exclusive, comprehensive or limiting in any way. Qualified contractors can be found in the Yellow Pages under "Water Damage Restoration" or "Fire & Water Damage Restoration". However, be sure you hire a firm with experience in sewer backups and enough resources to get the job done quickly.

---

**What you need to do now:**

---

- Contact a restoration company for clean up and removal of affected surfaces.
- Do not attempt to clean the area yourself, let the company you hire handle this.
- Keep people and pets away from the affected area(s).
- Turn off heating/air conditioning systems.
- Turn off any appliances that use water.
- Prevent any material from reaching floor vents to prevent contamination.
- Do not remove items from the area –the company you hire will handle these contents.
- If you had recent plumbing work, contact your plumber or contractor.
- Contact your homeowner's insurance carrier to report a claim.
- If you believe the City is responsible for damages you may file a claim. Complete the enclosed claim form and mail it to:

Risk Management  
City of Davis  
23 Russell Boulevard  
Davis, CA 95616

**Important Legal Notice:** For your protection, read carefully, obtain a reliable translation, and/or consult your attorney.

**Paquete de respuesta ante desborde/obstrucción del alcantarillado sanitario**  
**Información del cliente sobre reclamaciones de respaldo de**  
**alcantarillado**

Estimado Propietario:

Somos conscientes de que los incidentes de alcantarillado de flujo puede ser estresante. La ciudad ha preparado este breve conjunto de instrucciones que le ayudarán a minimizar el impacto de la pérdida por responder rápidamente a la situación.

La Ciudad no es responsable por los gastos de limpieza o daños causados por bloqueos en la línea de la alcantarilla del dueño de la propiedad o por violaciones de código. Independientemente de si usted o la Ciudad es responsable de la pérdida, depende de usted arreglar la reparación de su propiedad. Si la Ciudad es responsable de los daños, puede optar por que la empresa de restauración facture a la Ciudad directamente para la limpieza.

Usted o el dueño de la propiedad debe inmediatamente ponerse en contacto con una empresa para la limpieza de las zonas afectadas. Si usted no sabe de una empresa de solicitar un servicio, las siguientes 24 horas, empresas de restauración de emergencia están disponibles para responder:\*

| Empresa de Restauración       | Ubicación                                      | Teléfono     |
|-------------------------------|--|--------------|
| SERVPRO                       | PO Box 2263 Davis CA 95617                     | 530-756-1414 |
| Restoration Management Co.    | 1804 Enterprise Blvd. West Sacramento CA 95691 | 800-400-5058 |
| COIT Cleaning and Restoration | 3499 Business Dr. Sacramento CA 95820          | 916-731-7090 |

\* Esta lista se proporciona como un único recurso. La ciudad no necesita ni aprueba el uso de cualquiera de estas empresas. Esta lista no debe ser interpretado como exclusiva, completa o limitar de ninguna manera. Contratistas calificados se pueden encontrar en las páginas amarillas bajo "Restauración de daños causados agua" o "Fuego y Agua Restauración de daños causados". Sin embargo, asegúrese de contratar a una empresa con experiencia en las copias de seguridad de drenaje y los recursos suficientes para hacer el trabajo rápidamente.

**Lo que necesita saber en este momento:**

- Póngase en contacto con una empresa de restauración para la limpieza y eliminación de las superficies afectadas.
- No intente limpiar el área, deje que la empresa de contratar a manejar esto.
- Mantenga a las personas ya las mascotas alejados de la zona afectada (s).
- Apague la calefacción / aire acondicionado.
- Apague todos los electrodomésticos que utilicen agua.
- Evite que el material alcance respiraderos del piso para evitar la contaminación.
- No quitar elementos de la zona-la empresa que se encargará de contratar a estos contenidos.
- Si ha tenido el trabajo de plomería reciente, póngase en contacto con un plomero o contratista.
- Póngase en contacto con soporte de su seguro de propietario para presentar una reclamación.
- Si usted cree que la ciudad es responsable de los daños que puede presentar una reclamación. Completar el formulario de solicitud adjunta y enviarla por correo a:

Risk Management  
City of Davis  
23 Russell Boulevard  
Davis, CA 95616:

**Aviso legal importante:** Para su protección, lea atentamente el material, obtenga una traducción confiable y/o hable con su abogado.



**VERIFIED CLAIM**

CLAIM AGAINST: CITY OF DAVIS



(FOR CITY USE ONLY)

Claim No. \_\_\_\_\_

Received By: \_\_\_\_\_ Via: \_\_\_\_\_

- U.S. Mail
- Inter-Office Mail
- Over the Counter
- Drop Box

Date Received: \_\_\_\_\_

*Notice: The City of Davis may prosecute on the basis of Section 72 of the Penal Code (Ca. Ins. Code 1871) which provides: "Every person who, with intent to defraud, presents for allowance or for payment to any state board or office, or to any county, town, city, district, ward or village board or officer, authorized to allow or pay the same if genuine, any false or fraudulent claim, bill, account, voucher, or writing, is guilty of a felony."*

A claim must be filed with the City of Davis within a period provided by state statute after which the incident or event occurred. Be sure your claim is against the City of Davis and not another public entity. Completed claims must be mailed or delivered to:

**Risk Management  
City of Davis  
23 Russell Boulevard  
Davis, CA 95616**

PLEASE **PRINT** OR **TYPE**:

|                              |              |                           |                           |
|------------------------------|--------------|---------------------------|---------------------------|
| Name of Claimant             |              | Date of Birth of Claimant |                           |
| Home Address of Claimant     | City & State | Zip Code                  | Home Telephone Number     |
| Business Address of Claimant | City & State | Zip Code                  | Business Telephone Number |

Give address and telephone number to which you desire notices or communication to be sent regarding this claim.

Claims for death, injury to person or to personal property must be filled out not later than six months after the occurrence. (Gov. Code Sec. 911.2) Claims for damages to real property must filled out not later than 1 year after the occurrence.

1. Date, time and place (be specific) where damage or injury occurred? If Claim is for Equitable Indemnity, give date claimant served with the complaint: Date: \_\_\_\_\_

Please use diagram for clarification. Indicate names of streets and direction (north, south, east and west.) If the diagram does not fit the situation, please attach a proper diagram signed by the claimant.

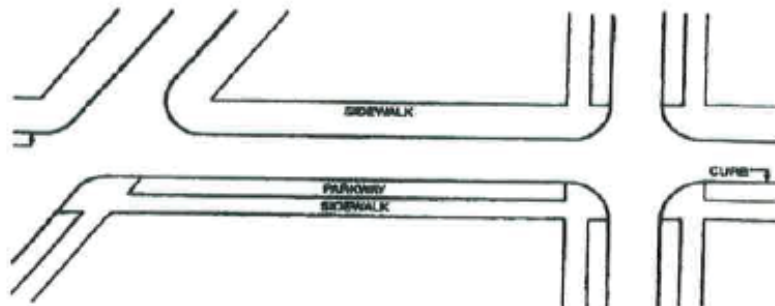

2. How did the damage or injury occur? (Give full details and attach second sheet, if necessary.)

3. What particular act or omission or individual caused the damage or injury?

4. What damages or injuries do you claim resulted? (Give full extent of damages or injuries claimed.)

5. The amount claimed as of the date of presentation of this claim is computed as follows: (please attach 2 estimates for repair, claimant must sign all documents.)

|  |          |   |          |
|--|----------|---|----------|
| <b>Damage incurred to date (exact):</b>                                      |          | <b>Estimated prospective damages as far as known:</b> |          |
| Damage to property.....  | \$ _____ | Future expenses for medical and hospital care..       | \$ _____ |
| Expenses for medical and hospital care.....                                  | \$ _____ | Future loss of earnings.....                          | \$ _____ |
| Loss of earnings.....  | \$ _____ | Other prospective special damages.....                | \$ _____ |
| Special damages.....   | \$ _____ | Total estimate prospective damages.....               | \$ _____ |
| General damages.....   | \$ _____ |   |          |
| Total damages incurred to date.....  | \$ _____ |   |          |
| Total amount claimed as of date of presentation of this claim:               |          | \$ _____  |          |
| Insurance payments received, if any, and names of insurance companies: _____ |          |   |          |

Section 111 of the Medicare Medicaid & S-CHIP Extension Act requires the entity to report certain claims to the federal government. Please indicate if the claimant is: 65 years of age or older, or is receiving Social Security Disability Insurance Benefits for 24 or more months, or has End Stage Renal Disease. If yes, you may be required to provide additional information to process your claim

Yes / No

(circle one)

If amount claimed is more than \$10,000:

**Jurisdiction:** \$10,000.00 to \$25,000.00 – Municipal Court  
\$25,001.00 and above – Superior Court

Was damage and/or injury investigated by police? \_\_\_\_\_

Were paramedics or ambulance called? \_\_\_\_\_

If injured, state date, time, name and address of doctor of your first visit \_\_\_\_\_

Date: \_\_\_\_\_

Time: \_\_\_\_\_

Name and Addresses of Witnesses to incident: \_\_\_\_\_

Name \_\_\_\_\_ Address \_\_\_\_\_ Phone \_\_\_\_\_

Name \_\_\_\_\_ Address \_\_\_\_\_ Phone \_\_\_\_\_

Name \_\_\_\_\_ Address \_\_\_\_\_ Phone \_\_\_\_\_

I have read the matters and statements made in the above claim and I know the same to be true of my own knowledge, except as to those matters stated upon information or belief and as to such matters I believe the same to be true. I certify under penalty of perjury that the foregoing is TRUE and CORRECT.

Signed this \_\_\_\_\_ day of \_\_\_\_\_, 20\_\_\_\_ at \_\_\_\_\_ (location)

CLAIMANT'S SIGNATURE

(Omitting information may make your claim legally insufficient; answer all questions.)

## How a Sewer System Works

A property owner's sewer pipes are called **service laterals** and are connected to larger local main and regional trunk lines. Service laterals run from the connection at the home to the connection with the public sewer. These laterals are the responsibility of the property owner and must be maintained by the property owner.

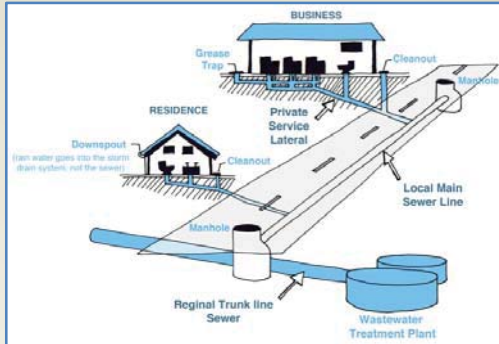

## Is my home required to have a backflow prevention device?

Section 710.1 of the Uniform Plumbing Code (U.P.C.) states: "Drainage piping serving fixtures which have flood level rims located below the elevation of the next upstream manhole cover or private sewer serving such drainage piping **shall** be protected from backflow of sewage by installing an approved type of backwater valve."

The intent of Section 710.1 is to protect the building interior from mainline sewer overflows or surcharges.

Additionally, U.P.C. 710.6 states: "Backwater valves **shall** be located where they will be accessible for inspection and repair at all times and, unless continuously exposed, shall be enclosed in a masonry pit fitted with an adequately sized removable cover."

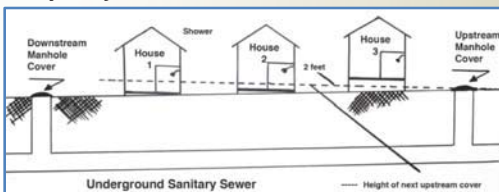

**If you have a sewage spill from your private sewer line that impacts storm drains, waterways or public property, contact:**

**City of Davis Public Works**  
(530) 757-5686

**Yolo County Environmental Health**  
(530) 666-8646

California Health and Safety Code, Sections 5410-5416 requires:

- No person shall discharge raw or treated sewage or other waste in a manner that results in contamination, pollution, or a nuisance.
- Any person who causes or permits a sewage discharge to any state waters, or if sewage probably will be discharged in or on any waters of the state:
  - Must immediately notify the local health agency of the discharge.
  - Shall reimburse the local health agency for services that protect the public's health and safety.
  - Who fails to provide the required notice to the local health agency is guilty of a misdemeanor and shall be punished by a fine (between \$500-\$1,000) and/or imprisonment for less than one year.

**Central Valley Regional Water Quality Control Board**

(916) 464-3291

Requires the prevention, mitigation, response to, and reporting of sewage spills.

**California Governor's Office of Emergency Services (CalOES)**

(800) 852-7550

California Water Code, Article 4, Chapter 4, Sections 13268-13271 & California Code of Regulations, Title 23, Division 3, Chapter 9.2, Article 2, Sections 2250-2260 require:

- Any person who causes or permits sewage in excess of 1,000 gallons to be discharged to state waters shall immediately notify the Office of Emergency Services.
- Any person who fails to provide the notice required by this section is guilty of a misdemeanor and shall be punished by a fine (less than \$20,000) and/or imprisonment for not more than one year.

# Sewer Spill Reference Guide

## Your Responsibilities as a Private Property Owner

Provided to you by:

**City of Davis  
Public Works**

**(530) 757-5686**

[www.cityofdavis.org](http://www.cityofdavis.org)

Copyright © 2004-2016  
DKF Solutions Group  
All rights reserved.

## How do sewage spills happen?

Sewage spills occur when the wastewater in underground pipes overflows through a manhole, cleanout, or broken pipe. Most spills are relatively small and can be stopped and cleaned up quickly, but left unattended they can cause health hazards, damage to homes and businesses, and threaten the environment, local waterways, and beaches.

### CAUTION!

**When trying to locate a sewer problem, never open manholes or other public sewer structures. Only our crews are allowed to open & inspect these structures.**

## Common causes of sewage spills

- Grease build-up
- Tree roots
- Broken/cracked pipes
- Missing or broken cleanout caps
- Undersized sewers
- Groundwater/rainwater entering the sewer system through pipe defects and illegal connections

## Prevent most sewage backups with a Backflow Prevention Device

This type of device can help prevent sewage backups into homes and businesses. If you don't already have a Backflow Prevention Device, contact a professional plumber or contractor to install one as soon as possible.

## Protect the environment!

If you let sewage from your property discharge to a gutter or storm drain, you may be subject to penalties and/or out-of-pocket costs for clean-up and enforcement efforts. A property owner may be charged for costs incurred by agencies responding to spills from private properties.

## What to look for:

Sewage spills can be a very noticeable gushing of water from a manhole or a slow water leak that may take time to be noticed. Don't dismiss unaccounted-for wet areas. Look for:

- Drain backups inside the building.
- Wet ground and/or water leaking around manhole lids onto your street.
- Leaking water from cleanouts or outside drains
- Unusual odorous wet areas: sidewalks, external walls, ground/landscape around a building.

The following are indicators of a possible obstruction in your sewer line:

- Water comes up in floor drains, showers or toilets.
- Toilets, showers or floor drains below ground level drain very slowly.

## What to do if there is a spill:

Immediately notify the City of Davis. Our crews locate the blockage and determine if it is in the public sewer; if it is the crew removes the blockage and arranges for cleanup. If the backup is in your private internal plumbing or in the private service laterals, you are required to immediately:

- Control and minimize the spill by shutting off or not using the water
- Keep sewage out of the storm drain system using sandbags, dirt and/or plastic sheeting
- Call a plumbing professional to clear blockages and make repairs as needed. Look in the yellow pages under "Plumbing Drain & Sewer Cleaning" or "Sewer Contractors."
- Always notify your sewer/public works department or public sewer district of sewage spills.

## Spill cleanup inside the home:

For large clean ups, a professional cleaning firm should be contacted to clean up impacted areas. You can locate local firms by looking in the Yellow Pages under "Water Damage" or "Fire Damage." If you hire a contractor, it is recommended to get estimates from more than one company. Sometimes, homeowner's insurance will pay for the necessary cleaning due to sewer backups. Not all policies have this coverage, so check with your agent.

If you decide to clean up a small spill inside your home, protect yourself from contamination by observing the following safety measures. Those persons whose resistance to infection is compromised should not attempt this type of clean up.

## Other Tips:

- Keep children and pets out of the affected area until cleanup has been completed.
- Turn off heating/air conditioning systems
- Wear rubber boots, rubber gloves, and goggles during cleanup of the affected area.
- Discard items that cannot be washed and disinfected (such as: mattresses, rugs, cosmetics, baby toys, etc.)
- Remove and discard drywall and insulation that has been contaminated with sewage or flood waters.

- Thoroughly clean all hard surfaces (such as flooring, concrete, molding, wood and metal furniture, countertops, appliances, sinks and other plumbing fixtures) with hot water and laundry or dish detergent.
- Help the drying process with fans, air conditioning units, and dehumidifiers.
- After completing cleanup, wash your hands with soap and water. Use water that has been boiled for 1 minute (allow the water to cool before washing your hands) OR use water that has been disinfected (solution of 1/8 teaspoon of household bleach per 1 gallon of water). Let it stand for 30 min. If water is cloudy, use ¼ teaspoon of household bleach per 1 gallon of water.
- Wash clothes worn during cleanup in hot water and detergent (wash apart from uncontaminated clothes).
- Wash clothes contaminated with sewage in hot water and detergent. Consider using a Laundromat until your onsite wastewater system has been professionally inspected and serviced.
- Seek immediate attention if you become injured or ill.

## Spill cleanup outside the home:

- Keep children and pets out of the affected area until cleanup has been completed.
- Wear rubber boots, rubber gloves, and goggles during cleanup of affected area.
- Clean up sewage solids (fecal material) and place in properly functioning toilet or double bag and place in garbage container.
- On hard surfaces areas such as asphalt or concrete, it is safe to use a 2% bleach solutions, or ½ cup of bleach to 5 gallons of water, but don't allow it to reach a storm drain as the bleach can harm the environment.
- After cleanup, wash hands with soap and water. Use water that has been boiled for 1 minute (allow to cool before washing your hands) OR use water that has been disinfected (solution of 1/8 teaspoon of household bleach per 1 gallon of water). Let it stand for 30 min. If water is cloudy, use ¼ teaspoon of household bleach per 1 gallon of water.
- Wash clothes worn during cleanup in hot water and detergent (wash apart from uncontaminated clothes).
- Wash clothes contaminated with sewage in hot water and detergent. Consider using a Laundromat until your onsite wastewater system has been professionally inspected and serviced.
- Seek immediate attention if you become injured/ill.



Overflow Emergency Response Plan  
Public Posting

# DANGER

**RAW SEWAGE • AVOID CONTACT**



# PELIGRO

**AGUA CONTAMINADA • EVITE TODO CONTACTO**

For more information

Para más información

**City of Davis**

**(530) 757-5686**

**City of Davis**

**City of Davis**

On (date) \_\_\_\_\_, at (location) \_\_\_\_\_,

On (date) \_\_\_\_\_, at (location) \_\_\_\_\_,

we responded to a reported blockage of the sanitary sewer service to your property.

we responded to a reported blockage of the sanitary sewer service to your property.

We discovered a blockage in:

We discovered a blockage in:

- The City sanitary sewer and cleared the line
- Your sanitary sewer lateral, which is your responsibility to maintain.

- The City sanitary sewer and cleared the line
- Your sanitary sewer lateral, which is your responsibility to maintain.

If you require assistance to clear your portion of the lateral you can look on the Internet or in the Yellow Pages of your telephone book under "Sewer Contractors" or "Plumbing Drains & Sewer Cleaning". If you plan to hire a contractor we recommend getting estimates from more than one company.

If you require assistance to clear your portion of the lateral you can look on the Internet or in the Yellow Pages of your telephone book under "Sewer Contractors" or "Plumbing Drains & Sewer Cleaning". If you plan to hire a contractor we recommend getting estimates from more than one company.

City of Davis representative notes:

City of Davis representative notes:

\_\_\_\_\_  
\_\_\_\_\_  
\_\_\_\_\_

\_\_\_\_\_  
\_\_\_\_\_  
\_\_\_\_\_

City of Davis Representative:

City of Davis Representative:

\_\_\_\_\_

\_\_\_\_\_

**For questions or comments, please call  
City of Davis  
(530) 757-5686**

**For questions or comments, please call  
City of Davis  
(530) 757-5686**

**For sewer emergencies  
at night and on weekends, please call  
(530) 758-3600**

**For sewer emergencies  
at night and on weekends, please call  
(530) 758-3600**

**Appendix C**  
**FIELD SAMPLING KIT**

**Field Sampling Kit  
Table of Contents**

| <b><u>Form</u></b>   | <b><u>Form Number</u></b> |
|--|---------------------------|
| Procedures for Sampling Receiving Waters and Posting Warnings after a Sewage Spill ..... | C-1                       |
| Sample Collection Chain of Custody Record .....  | C-2                       |

**Go to Water Quality Sampling Area and get the following supplies:**

- Ice pack
- Ice
- Sample pole
- Latex gloves
- Long rubber gloves
- Safety glasses
- Waterproof Pen (i.e. Sharpie®)
- Chain of Custody form
- Sample Containers
  - Bac-T
  - Ammonia



**Field Sampling Kit**  
**Procedures for Sampling Receiving Waters and Posting Warnings after a SSO**

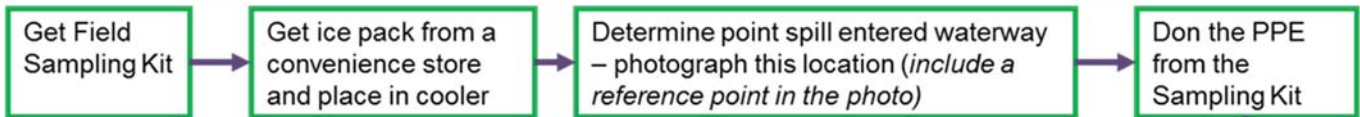

- Collect all samples against the direction of the water flow! (face upstream)
- Collect upstream sample first!
- Collect samples well away from the bank (preferably where water is visibly flowing) and 6" below the surface
- Avoid sampling debris or scum layer from the surface.
- Photograph evidence of dead fish!

Move 50' upstream of point where spill entered waterway (reference sample)

**SAMPLING STEPS**

Take out the temp/pH meter. Calibrate it. Take temperature and pH of the water at that sample location. Record those results on the chain of custody form.

Remove the seal from the enterococcus sample container (100ml) just prior to collecting your sample. A chemical has been added to the sample container. Leave the chemical in the bottle and do not rinse.

1. Remove the cap immediately before collecting each sample.
2. Do not allow the inside of the cap to touch anything
3. Holding the bottle in one hand, face upstream and lower the bottle 6" below the water surface. Then sweep the bottle upstream and out of the water. Be careful not to disturb the bottom sediment. Pour a little water out so that bottle is filled to the line. Immediately replace the cap.

Open the ammonia-nitrogen sample container and follow collection process above (steps 1-3) to fill to just below the neck of the jar. NOTE: The ammonia-nitrogen sample bottle contains sulfuric acid – LEAVE THE ACID IN THE BOTTLE AND DO NOT ALLOW IT TO TOUCH YOUR SKIN!

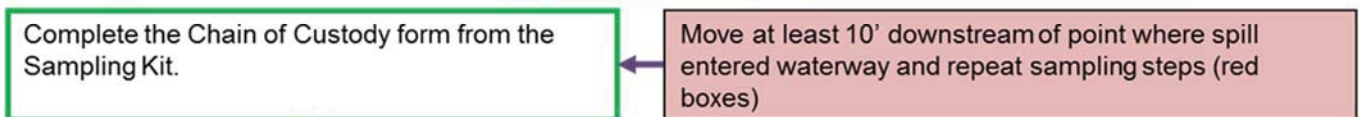
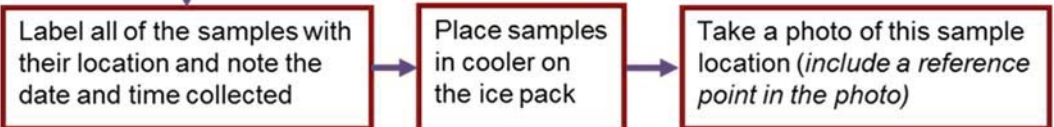

Post warning signs as directed by the County Environmental Health Department, and remove warning signs and lift restrictions when authorized by County Environmental Health.

Repeat sampling daily from time the spill is known until the results of two consecutive sets of samples indicate the return to the normal level or cessation of monitoring is authorized by the County Environmental Health Department.

**Field Sampling Kit**  
**Procedures for Sampling Receiving Waters after a SSO**

This example is provided for illustrative purposes *only!* Base each sampling event on the geography, drainage and interference factors (*i.e. birds, animals, runoff, etc.*) of the area impacted. Consult the Contract Laboratory as needed.

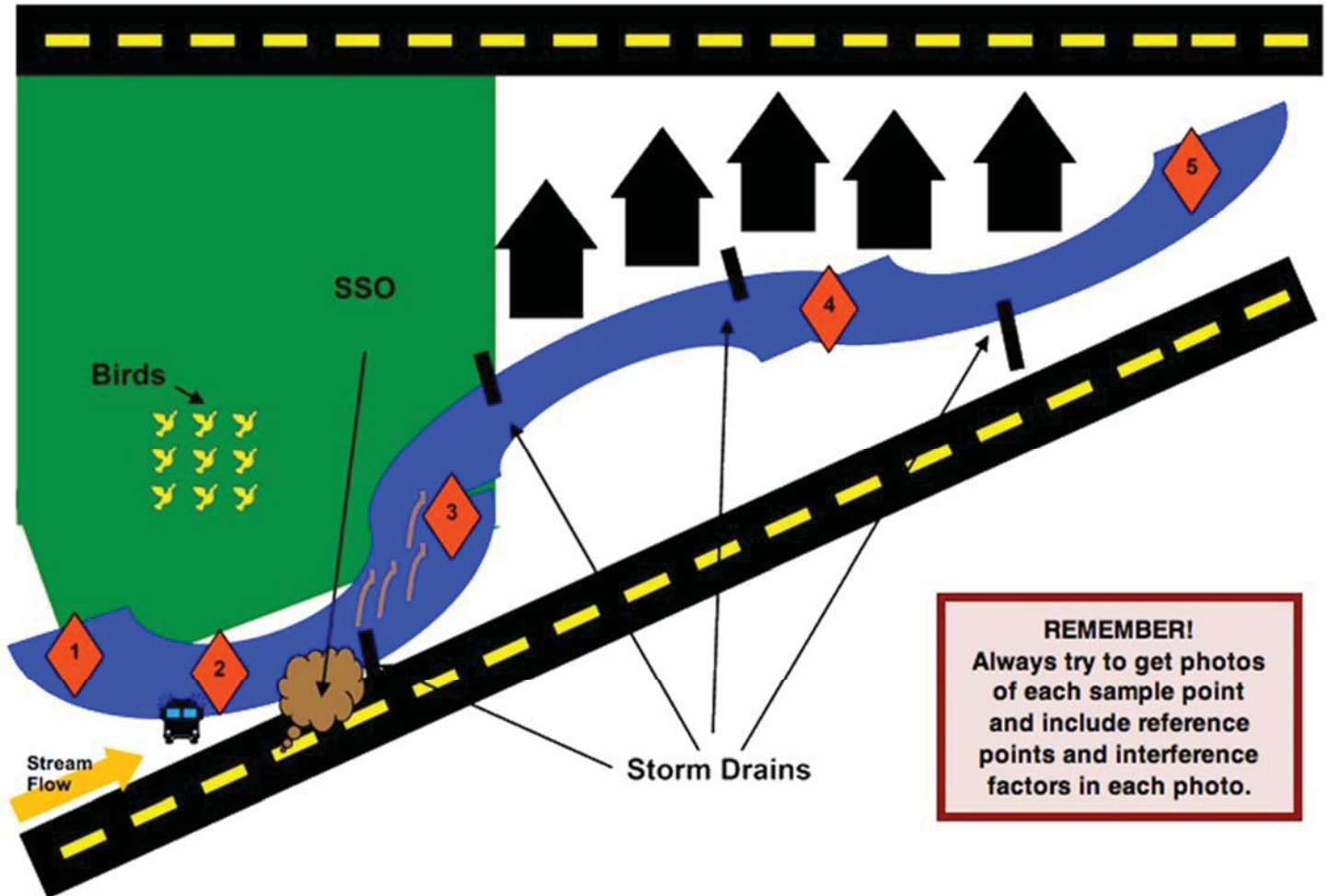

- 1** Sample Location 1: Baseline Sample, no observable interference from birds, animals, runoff, etc
- 2** Sample Location 2: Baseline Sample, observable interference from birds, animals, runoff, etc  
*NOTE:* Only collect this sample if you observe any possible interfering factors upstream from the spill location
- 3** Sample Location 3: Immediately downstream of SSO entry point
- 4** Sample Location 4: Further downstream of SSO entry point – note any possible interfering factors
- 5** Sample Location 5: Further downstream of SSO entry point – note any possible interfering factors

**Field Sampling Kit  
Sample Collection Chain of Custody Record**

|                                |  |                          |                         |                                 |   |
|--------------------------------|--|--------------------------|-------------------------|---------------------------------|---|
| <b>Customer Name</b>           |  | <input type="checkbox"/> | <b>Hazardous Waste</b>  | <b>PO#</b>                      |   |
| <b>Customer Address</b>        |  | <input type="checkbox"/> | <b>Unknown Material</b> | <b>WO#</b>                      |   |
| <b>Customer Telephone</b>      |  | <b>Mail Code</b>         |                         | <b>CONTRACT LAB INFORMATION</b> |   |
| <b>Program Name</b>            |  |                          |                         | <b>Turnaround Requirement</b>   |   |
| <b>Lab Program Coordinator</b> |  | <b>Phone #</b>           |                         | Ship to:                        | <input type="checkbox"/> Normal (21 days) |
| <b>Sampled By</b>              |  |                          |                         | Ship Date:                      | <input type="checkbox"/> Rush: _____      |
|                                |  |                          |                         | Courier:                        | <input type="checkbox"/> Other: _____     |

| LIMS#<br>(Issued by Lab) | SAMPLE COLLECTION INFORMATION |      |                          |                                     |                 |          |            | Container # | Matrix* | Analysis Requested                  |                                     |                          |                          |                          | QA/QC Requirements                  |                        |
|--------------------------|-------------------------------|------|--------------------------|-------------------------------------|-----------------|----------|------------|-------------|---------|-------------------------------------|-------------------------------------|--------------------------|--------------------------|--------------------------|-------------------------------------|------------------------|
|                          | Date                          | Time | Type                     |                                     | Sample Location | Field pH | Field Temp |             |         | Ammonia                             | Enterococ US                        |                          |                          |                          | <input checked="" type="checkbox"/> | Lab Standard           |
|                          |                               |      | B                        | G                                   |                 |          |            |             |         |                                     |                                     |                          |                          |                          | <input type="checkbox"/>            | Special (see attached) |
|                          |                               |      | <input type="checkbox"/> | <input checked="" type="checkbox"/> | Upstream        |          |            | 2           | A       | <input checked="" type="checkbox"/> | <input checked="" type="checkbox"/> | <input type="checkbox"/> | <input type="checkbox"/> | <input type="checkbox"/> |                                     |                        |
|                          |                               |      | <input type="checkbox"/> | <input checked="" type="checkbox"/> | Entry Point     |          |            | 2           | A       | <input checked="" type="checkbox"/> | <input checked="" type="checkbox"/> | <input type="checkbox"/> | <input type="checkbox"/> | <input type="checkbox"/> |                                     |                        |
|                          |                               |      | <input type="checkbox"/> | <input checked="" type="checkbox"/> | Downstream      |          |            | 2           | A       | <input checked="" type="checkbox"/> | <input checked="" type="checkbox"/> | <input type="checkbox"/> | <input type="checkbox"/> | <input type="checkbox"/> |                                     |                        |
|                          |                               |      | <input type="checkbox"/> | <input type="checkbox"/>            |                 |          |            | 2           |         | <input type="checkbox"/>            | <input type="checkbox"/>            | <input type="checkbox"/> | <input type="checkbox"/> | <input type="checkbox"/> |                                     |                        |
|                          |                               |      | <input type="checkbox"/> | <input type="checkbox"/>            |                 |          |            | 2           |         | <input type="checkbox"/>            | <input type="checkbox"/>            | <input type="checkbox"/> | <input type="checkbox"/> | <input type="checkbox"/> |                                     |                        |
|                          |                               |      | <input type="checkbox"/> | <input type="checkbox"/>            |                 |          |            | 2           |         | <input type="checkbox"/>            | <input type="checkbox"/>            | <input type="checkbox"/> | <input type="checkbox"/> | <input type="checkbox"/> |                                     |                        |

\*Matrix: P = Potable Water, W = Wastewater, A = Ambient Water, G = Groundwater, S = Soil, B = Biosolids, I = Industrial, O = Other (specify in remarks)

| Relinquished | Date | Time |
|--------------|------|------|
|              |      |      |
|              |      |      |
|              |      |      |

| Relinquished to | Date | Time |
|-----------------|------|------|
|                 |      |      |
|                 |      |      |
|                 |      |      |

| Transport/Shipping Information  |                              |                                |
|---------------------------------|------------------------------|--------------------------------|
| <input type="checkbox"/> USPS   | <input type="checkbox"/> UPS | <input type="checkbox"/> FedEx |
| Tracing #:                      |                              |                                |
| <input type="checkbox"/> Other: |                              |                                |

**Sample Receiving Documentation**

|  |   |   |  |
|--|---|---|--|
| Container intact? <input type="checkbox"/> Yes <input type="checkbox"/> No   | Correct container? <input type="checkbox"/> Yes <input type="checkbox"/> No | Field preserved? <input type="checkbox"/> Yes <input type="checkbox"/> No | Custody tape intact? <input type="checkbox"/> Yes <input type="checkbox"/> No  |
| Cooled? <input type="checkbox"/> Yes <input type="checkbox"/> No   | Temp. Blank? <input type="checkbox"/> Yes <input type="checkbox"/> No ( °C) | Comments:   |  |
| Sample distribution: <input type="checkbox"/> Lab bench <input type="checkbox"/> Ice chest <input type="checkbox"/> Walk-in cooler shelf # |   | Disposal Date:  | Disposed by: (inits.)  |
| C-O-C Distribution   | Date:                      By:  | <input type="checkbox"/> Lab Admin File                                   | <input type="checkbox"/> Prog/proj Mgr. <input type="checkbox"/> Lab Prog. Coord. <input type="checkbox"/> Delivery courier <input type="checkbox"/> Pick-up courier |

**Appendix D**

**CONTRACTOR ORIENTATION  
(DRAFT)**



**Contractor Orientation**

The following procedures are to be followed in the event that you cause or witness a Sanitary Sewer Overflow.

**Contractor causes or witnesses a Sanitary Sewer Overflow**

**Immediately notify the City**

Business Hours: (530) 757-5686  
After Hours: (530) 758-3600

**Protect the storm drains**

Using mats, dikes, berms, etc.

**Protect the Public**

If the spill is entering an area where public contact may occur and if it is safe to do so, monitor the location until the City Collection Crew or other Field Crew arrives.

**Provide Information**

Provide the City Collections Crew or other Field Crew with information about the overflow such as start time, appearance point, suspected cause, weather conditions, etc.

**Direct ALL media and public relations requests to the Wastewater Division Manager at (530) 747-8283**

# Sanitary Sewer Overflows

How to avoid them and what to do if you don't

## What?

A sanitary sewer overflow (SSO) is a discharge of untreated human and industrial waste before it reaches the wastewater treatment facility.

## Where?

SSOs usually occur through manholes, plumbing fixtures and service cleanouts.

## Why?

SSOs are usually caused by grease, debris, root balls, or personal hygiene products blocking the sewer lines, or by unusually high flow volume.

### How to prevent SSOs:

#### ...when clearing plugged sewer laterals:

Remove root balls, grease blockages and any other debris from the sewer

If you can't prevent root balls, grease or debris from entering the sewer main, call us at (650) 757-5686, so we can work with you to remove the blockage and prevent blockages further downstream

Use plenty of water to flush lines.

#### ...when constructing or repairing sewer laterals:

Refer to the City website for standard design criteria and permit requirements. Go to [www.cityofdavis.org](http://www.cityofdavis.org).

Check your work area. Make sure there is no debris left in the sewer line before you backfill.

Avoid offset joints, which may make sewer lines vulnerable to root intrusion and grease or debris accumulation. Properly bed your joints and don't hammer tap.

If you cause or witness an SSO, immediately contact:

### City of Davis

Business Hours:  
(530) 757-5686

After hours:  
(530) 758-3600

City of Davis  
Public Works

1717 Fifth Street  
Davis, CA 95616

[www.cityofdavis.org](http://www.cityofdavis.org)