

# City of Davis

## Organics Processing Facility

### Feasibility Analysis



*Prepared for:*

**CITY OF DAVIS**  
Public Works Department  
1717 Fifth Street  
Davis, CA 95616

*Prepared by:*

**CLEMENTS ENVIRONMENTAL CORP.**  
15230 Burbank Blvd., Suite 103  
Sherman Oaks, CA 91411  
(818) 267-5100



*In association with:*

**Sloan Vazquez McAfee**  
**Diversion Strategies**

*Sloan***VAZQUEZ****McAFEE**  
MUNICIPAL SOLID WASTE ADVISORS



Executed July 2017  
Expanded August 2018  
Finalized May 2019



Technical Aspects  
 Environmental Aspects  
 Financial Aspects  
 Policy Aspects

**Comparative Evaluation Matrix ..... 94**

**7 PROJECT ECONOMICS ..... 96**

**8 GREENHOUSE GAS ANALYSIS ..... 102**

**9 RECOMMENDATIONS ..... 104**

**10 NEXT STEPS ..... 107**

**- LIST OF TABLES -**

**Table 1.1** City Alternative Projects Summary ..... 7

**Table 4.1** DWR Hauling Data Summary ..... 17

**Table 4.2** Yolo County Organics Generation..... 26

**Table 4.3** Estimated UCD Available Organics Tonnage ..... 27

**Table 4.4** Available Organic Feedstocks Summary ..... 29

**Table 4.5** Available Organic Feedstocks for Stand-Alone Composting..... 30

**Table 4.6** Available Organic Feedstocks for Anaerobic Digestion ..... 31

**Table 4.7** Available Organic Feedstocks for Composting with AD ..... 31

**Table 5.1** Top 10 Crops in the Yolo/Solano/Sacramento Region ..... 36

**Table 5.2** Costs for Common Compost Amendments ..... 38

**Table 5.3** Case A – AD-D Process; Organic Waste Quantity and Composition ..... 45

**Table 5.4** Case B – AD-C Process; Organic Waste Quantity and Composition ..... 45

**Table 5.5** Electric Power Generation Potential from Biogas Production –  
 WWTP Sludge Digestion and Organics AD-C Digestion ..... 48

**Table 6.1** Organics Growth Tonnage and Cost with YCCL Project ..... 64

**Table 6.2** Organics Growth Tonnage and Cost at Status Quo ..... 65

**Table 6.3** Static Pile vs. CASP General Comparison ..... 77

**Table 6.4** AD-D vs AD-C General Comparison ..... 81

**Table 6.5** WDR Tier I Percolation Rate and Depth to Groundwater Standards ..... 82

**Table 6.6** Estimated Emission Offsets Required per Compost Technology..... 84

**Table 6.7** Primary Transportation Impacts ..... 93

**Table 6.8** City of Davis Comparative Evaluation Matrix ..... 95

**Table 7.1** Financial Pro Forma Summary ..... 97

<b>Table 7.2</b>	City WWTP Key Financial Points .....	98
<b>Table 7.3</b>	CNG Value Assumptions.....	99
<b>Table 7.4</b>	UC Davis Project Key Financial Points .....	100
<b>Table 7.5</b>	Additional Project Scenarios Net Cost per Ton Comparison .....	101
<b>Table 8.1</b>	Annual MTCO <sub>2</sub> E Generated or Reduced Determined by WARM.....	102
<b>Table 8.2</b>	Anaerobic Digestion and Composting Operations Net Energy .....	103

### - LIST OF FIGURES -

<b>Figure 4.1</b>	YCCL Site Visit #1, City Organics Waste Photograph #1 .....	18
<b>Figure 4.2</b>	YCCL Site Visit #1, City Organics Waste Photograph #2 .....	18
<b>Figure 4.3</b>	YCCL Site Visit #1, City Organics Waste Photograph #3 .....	19
<b>Figure 4.4</b>	YCCL Site Visit #2, City Organics Waste Photograph #1 .....	20
<b>Figure 4.5</b>	YCCL Site Visit #2, City Organics Waste Photograph #2 .....	20
<b>Figure 4.6</b>	YCCL Site Visit #2, City Organics Waste Photograph #3 .....	21
<b>Figure 4.7</b>	YCCL Site Visit #2, City Organics Waste Photograph #4 .....	21
<b>Figure 4.8</b>	YCCL Site Visit #2, YCCL Green Waste Area Photograph #1 .....	22
<b>Figure 4.9</b>	YCCL Site Visit #3, City Organics Waste Photograph #1 .....	23
<b>Figure 4.10</b>	YCCL Site Visit #3, City Organics Waste Photograph #2 .....	23
<b>Figure 4.11</b>	YCCL Site Visit by DWR, City Organics Waste Photograph #1 .....	24
<b>Figure 5.1</b>	Examples of Anaerobic Digestion Processes .....	43
<b>Figure 5.2</b>	Increase in Food Waste Collection and Resulting Biogas Production .....	46
<b>Figure 5.3</b>	Biogas Production Potential Combining the Biogas Flows from the WWTP with the AD-C AD Process .....	47
<b>Figure 5.4</b>	Biogas Utilization Options .....	47
<b>Figure 5.5</b>	Biogas Processing Cost .....	50
<b>Figure 5.6</b>	Levelized Cost of Energy Comparison .....	50
<b>Figure 6.1</b>	YCCL Site Plan .....	57
<b>Figure 6.2</b>	YCCL Storm Water Drainage Plan .....	58
<b>Figure 6.3</b>	YCCL Anaerobic Composter Cell Site Plan .....	59
<b>Figure 6.4</b>	YCCL Liquid Waste and Food Waste Processing Area .....	60
<b>Figure 6.5</b>	Old City of Davis Landfill Available Land .....	67
<b>Figure 6.6</b>	City WWTP Available Land .....	70
<b>Figure 6.7</b>	City WWTP Organics Processing Facility Conceptual Site Plan .....	72
<b>Figure 6.8</b>	City WWTP Organics Processing Facility Conceptual Site Plan II .....	73
<b>Figure 6.9</b>	Static Pile Composting Facility Aerial .....	74
<b>Figure 6.10</b>	Static Pile Composting Pile Formation .....	75
<b>Figure 6.11</b>	GORE® Composting Facility Aerial .....	76

**Figure 6.12** GORE® Composting Facility Compost Piles ..... 76  
**Figure 6.13** SMARTFerm System at MRWMD ..... 78  
**Figure 6.14** SMARTFerm Conceptual Site Layout ..... 79  
**Figure 6.15** Eisenmann Main Digester Schematic ..... 80  
**Figure 6.16** Eisenmann Conceptual Site Layout ..... 80  
**Figure 6.17** UCD Available Land ..... 87  
**Figure 6.18** City Organics Processing Facility at UCD ..... 89  
**Figure 6.19** Potential Recology Organics Facilities ..... 91  
**Figure 6.20** Nearest Recology Facilities ..... 92

**- APPENDICES -**

**Appendix A** YCCL July 2018 Solid Waste Facility Permit  
**Appendix B** YCCL Waste Flow Diagram  
**Appendix C** YCCL Project Follow-up Technical (Tech.) Memo  
**Appendix D** Recology Davis Follow-up Tech. Memo  
**Appendix E** Alternative Project Financial Pro Forma  
**Appendix F** Additional Financial Pro Forma Scenarios  
**Appendix G** Project WARM Analysis  
**Appendix H** Composting Operations Energy Requirements Tech. Memo  
**Appendix I** Anaerobic Digestion Energy Balance Tech. Memo

# Section 1

## Executive Summary

The City of Davis hired the Clements Environmental team, including sub-contractors Sloan Vazquez McAfee and Diversion Strategies, to assess the feasibility of various organics processing scenarios for the diversion of organic waste from the landfill. These scenarios included:

1. Joining the County of Yolo's organics project at the Central Landfill;
2. Developing a new City-Sponsored Project at the Old City Landfill;
3. Developing a new City-Sponsored Project at the Wastewater Treatment Plant (WWTP);
4. Developing a new City-Sponsored Project at a site adjacent to the University of California (UC) Davis Anaerobic Digestion (AD) plant; and
5. Utilizing Recology's existing organics processing infrastructure.

For the new City-Sponsored Project, the Clements team evaluated two basic scenarios: a composting facility; or an AD facility co-located with a composting facility. For the latter, a composting operation is integral to the operation of the AD facility to handle the AD digestate and supernatant. The general types of technologies evaluated as best suited for this application were:

### **1. Composting**

- Covered Static Pile (12-inch compost cover)
- Covered Aerated Static Pile (CASP) (membrane cover)

### **2. Anaerobic Digestion (AD)**

- High Solids Discontinuous / Batch-Flow Type
- High Solids Continuous / Plug-Flow Type
  - *AD Biogas Use:*
    - Power Production
    - CNG Fuel

For purposes of this study, the team combined Covered Static Pile composting, the Discontinuous/Batch Flow AD, and biogas power production as the less sophisticated and less expensive scenario; and the Covered Aerated Static Pile (CASP) composting, the Continuous/Plug Flow AD, and the CNG production as the more sophisticated, higher performing, and expensive option. In this way, the range of project possibilities was covered, without having to analyze every possible combination of composting, AD, and biogas utilization technologies, which was beyond the scope of this work.

During the course of the study, Recology Davis purchased Davis Waste Removal. The Clements team provided input into the feasibility of the City committing its organic material to Recology

and tasking them with handling these feedstocks in their regional organics system. Most importantly, this system includes the Jepson Prairie Organics (JPO) composting operation near Vacaville.

## **APPROACH**

The Clements team gathered data by various methods and from numerous sources including:

1. Meetings and in-depth discussions with City staff, Davis Waste Removal, and Recology Davis
2. Meeting and discussions with UC Davis
3. Discussions with Yolo County
4. Meeting with the Yolo-Solano Air Quality Management District (YSAQMD)
5. Review of Davis Waste Removal's operations in the region
6. Discussions with composting and AD technology providers
7. Team knowledge of the organics handling industry in general and the City of Davis region in particular
8. Team pro formas generated over decades of work with facilities and operations in the solid waste field
9. EPA, CalRecycle, and other databases

This information was then used to assess the feasibility, costs, and benefits of the selected organics diversion opportunities available to the City.

## **FEEDSTOCKS**

This feedstock study was performed in July 2017, during the end of the first complete year of the City's organics collection program. The study, performed by Diversion Strategies, revealed that the City collected about 48 tons per day (TPD) of organic material from customers, comprised of roughly two percent (2%) food waste with the remainder as green and wood waste. The team expects the percentage of food waste to increase to typical municipal organics program rates of five percent (5%) in the residential sector and ten percent (10%) in the commercial sector, and perhaps even more as the organics source separation programs mature. The study found that the source-separated organic material was relatively free of contamination as compared to other cities with similar programs. This is a testament to both the effectiveness of the City's program design and education, and to the environmental ethic and performance of the residents of the City of Davis.

As provided by UC Davis in August 2017, the university generates approximately 48 TPD of organics that are available for City-Sponsored composting operation. These organics are made up of roughly 10% green waste, 1% food waste, and 4% digestate from their anaerobic digestion (AD) facility with the remainder (85%) animal manure and bedding. UC Davis also produces 10,000

gallons per day of liquid digestate from their AD facility that they would like to be included in this project. The University has expressed interest in a joint project with the City.

For the purposes of this study, the Clements team totaled the available organic waste streams from both the City and UC Davis for the City-owned and operated project options. Based on these waste streams, the project capacity was determined to be roughly 25,000 tons per year. In addition, the liquid digestate from the UC Davis AD could be used on-site to water compost windrows.

## **PRODUCTS MARKET ASSESSMENT**

In order for any organics management system to be effective, there must be a market for the products the system generates. In the case of this study, the key products are compost and/or biogas. The latter can be used to generate electricity, to produce Compressed Natural Gas (CNG) fuel for vehicles, or as renewable natural gas for injection in the utility gas pipeline. This study focused on the first two options for biogas as the quantities that could be generated were too low to make the more complex pipeline injection alternative feasible.

The results of the study found that there was a strong market for compost in the area with a value of roughly \$20 per ton.

Likewise, biogas produced from AD was found to be a valuable commodity as a generator of electricity to help power the WWTP; or even more so when converted to CNG vehicle fuel. The team determined the product revenue from sale of these renewable energies to be \$0.166 per kWh and \$4.03 per diesel gallon equivalent (DGE).

## **ALTERNATIVE PROJECT EVALUATIONS**

The Clements team evaluated five options as summarized below and in detail in the body of the report.

### Joining the County of Yolo's Organics Project at the Central Landfill

The Clements team evaluated the feasibility of the City participating in the Yolo County Central Landfill's (YCCL) organic processing project, which includes anaerobic composting cells, a liquid and foodwaste processing area, and an aerated static pile composting operation. This option offers advantages in that the City would only be required to guarantee delivery of their organics to the County project.

The most significant disadvantage for this option is the uncertain cost per ton (tipping fee) and stability of that tipping fee over time. Without knowing the actual cost of this project, it is difficult to assess the total cost of the City's participation. In addition, YCCL may require a long-term feedstock guarantee from the City, which will commit the City to the County project for potentially



decades into the future. This would eliminate the City's flexibility to change direction in programs or facilities as organics diversion progresses. The County's anaerobic composting cell technology, with the aeration and excavation components, is a new system developed by Yolo County. While the pilot program was deemed successful, the long-term successful performance of this system has not yet been proven.

### City Project at the Old City Landfill

Although the City's Old Landfill is a potential site for an organics facility, the team quickly eliminated this option from further analysis because:

- It is located relatively close to residential neighborhoods; and
- The City is strongly considering other uses for the site that would take precedent over an organics project.

### City Project at the WWTP

The major advantage of the City developing and operating an organics facility is the City's ability to control its own destiny. The City's WWTP is an excellent site for a composting or AD facility because:

- The City owns the land and there is large acreage vacant and available.
- The City would control much of the permitting and the CEQA process.
- The site is remote from sensitive receptors such as residential areas, schools, and hospitals.
- The hauling distance to the WWTP is nearly identical to hauling to YCCL.
- There are certain synergies between an organics project and the WWTP operations and its by-products.
  - Reclaimed water is available should an organics project, such as composting, require water for optimal processing conditions.
  - The WWTP creates biosolids that, in the future, could be co-composted with green and food waste
  - Both the WWTP and an AD facility generate biogas that could be combined to produce electricity, or converted to CNG.

The major disadvantages of this project are the capital expenditure required by the City and extensive permitting, that will require a long lead time. While the City will enjoy profits from the this project's products, the City will also be in charge of marketing these products which has potential risks if the demand is low.

### City Project at UC Davis

UC Davis has expressed interested in hosting a City-operated composting project adjacent to the university's AD facility. Since the team assessed the feasibility of an identical composting operation at the City's WWTP, the same technology design, cost, and revenue were applied to this project. This option would have minimal impact on the hauler, as the travel distance is similar to or less than to YCCL.

There are two options for a project at UCD: (#1) the City leases the UCD land and operates the organics processing facility, or (#2) the City participates in a UCD owned and operated facility.

#### *Option #1: City Lease and Operate*

The main advantage of a City-operated facility on UCD property is the support of a regional effort with the university. Other advantages include the site's remote location to sensitive receptors and current use for chipping and grinding activities and mulch storage.

However, the City would most likely be subject to a long-term lease agreement with UCD that could involve substantial cost as well as provisions whereby UCD could take over ownership or operation of the facility.

#### *Option #2: UCD Own and Operate*

The main advantage for City participation in a UCD-owned and operated facility is the support of a regional effort between the City and University. Other advantages include no infrastructure, permitting, or product-marking burden on the City.

The drawbacks to this project are similar to those involving City participation in the YCCL organics project, namely, the City would most likely be subject to a long-term feedstock guarantee which severely limits the City's flexibility in choosing future options.

Although this option is described in this report, it is not included in the final summary table of alternatives because there are too many unknown variables to estimate the cost.

### Recology, Inc.

During the course of this study, Recology, Inc. acquired Davis Waste Removal (DWR), both its business and all its assets. Since the acquisition in April 2018, the organics collections routes have remained the same. At the time of this study (December 2018), Recology does not anticipate any changes to routing and had not conducted any route optimization evaluations for City collection

routes. The collected organics from the City still go to YCCL for consolidation and transfer to a permitting compost facility, currently located in Napa.

The Clements team assessed the feasibility of utilizing Recology's nearest organics composting facility, Jepson Prairie Organics (JPO) located in Vacaville. In addition to assessing this option's technology, products, and cost, the team performed a transportation greenhouse gas (GHG) analysis to compare the GHG impacts as compared to the status quo, hauling to YCCL. Using CNG collection vehicles, direct haul to JPO would result in an increase of 5.85 lbs. of CO<sub>2</sub> equivalent (CO<sub>2</sub>E) per roundtrip, or roughly 3.17 times more CO<sub>2</sub>E into the atmosphere than one roundtrip to YCCL.

This option of directing organics to JPO, may be the quickest and simplest option for the City. Recology may be able to offer the City a beneficial price structure for organics if the City also agrees to send its solid waste to Recology's Hay Road Landfill for disposal. This option also demands no infrastructure, permitting, or product marketing efforts from the City.

As with any project where the City is not the operator, the City will be required to commit to a feedstock guarantee and, therefore, will have little control moving into the future as compared to City-Sponsored options. The City would be subject to the cost per ton as determined by Recology, which could change significantly and suddenly, unless carefully constrained in contract language.

## PROJECT ECONOMICS

The team used data from current composting and AD operations, recent grant applications, and select literature to populate the Sloan/Vazquez/McAfee pro forma for each of the options for City-developed projects. We also utilized data from the City on labor rates, power pricing, and other factors. It should be emphasized that this is a "concept level" analysis and is not meant as a definitive cost evaluation. It does offer a general comparison of costs and revenues between composting and AD scenarios, and provides a yardstick with which to compare future organics projects with existing costs, and other options, such as a proposal from Recology.

**Table 1.1** on the next page provides a summary of the Alternative Projects showing each option's technology type, costs, and revenues. The alternative projects' processing capacity shown in **Table 1.1** is based on the available organics from both City of Davis and UC Davis. Alternative feedstock scenarios (i.e., City-only feedstock, four times City feedstock, feedstock without C&D) are assessed in the financial proformas in *Appendix E*.

Capital costs include site preparation and purchasing necessary equipment such as material handling equipment (e.g., trommel screen, tub grinder) and technology-specific equipment (CASP or AD system). The annual operating costs are the combined estimated direct labor and equipment expenditures required.

**Table 1.1 City Alternative Projects Summary<sup>1</sup>**

PROJECT	TECH	TYPE	CAPITAL COST (millions)	OPERATING COSTS / YEAR	PRODUCTS GENERATED	PRODUCT REVENUE / YEAR <sup>2</sup>	NET \$ / TON
1) YCCL	Anaerobic Composter Cells	N/A	N/A	N/A	Power Production + Compost	\$0	\$63.00 <sup>3</sup>
2) Old City Landfill	N/A	N/A	N/A	N/A	N/A	N/A	N/A
3) City WWTP	A) Stand-Alone Composting	Covered Static Pile (12-inch compost cover)	\$0.98	\$576,449	Compost	\$339,682	\$19.69
	B) Stand-Alone Composting	CASP (membrane cover)	\$4.26	\$491,560	Compost	\$339,682	\$46.06
	C) AD + Composting	Discontinuous (AD-D) + Covered Static Pile	\$6.60	\$951,353	Power Production + Compost	\$514,932	\$77.66
	D) AD + Composting	Continuous (AD-C) + CASP	\$13.72	\$1,064,998	CNG Fuel + Compost	\$918,049	\$123.03
4) UC Davis <sup>4,5</sup>	E) Stand-Alone Composting	Covered Static Pile	\$0.98	\$576,449	Compost	\$339,682	\$19.69
	F) Stand-Alone Composting	CASP	\$4.26	\$491,560	Compost	\$339,682	\$46.06
5) Recology JPO	Composting	Aerated Static Piles (ASP)	N/A	N/A	Compost	\$0	\$80.00 <sup>6</sup>

<sup>1</sup>Total tons per day (TPD) is based on the available organics from both City of Davis and UC Davis and assumes 22 working days per month (264 days per year). Alternative feedstock quantities (i.e., City-only feedstock, four times City feedstock, feedstock without C&D) are assessed in the financial proformas in *Appendix E*.

<sup>2</sup>Annual revenue to City for product sales.

<sup>3</sup>Tip fee was provided by Yolo County Central Landfill (YCCL); YCCL developed this estimated tip fee late 2016, and at the time of this report has yet to provide an updated tip fee.

<sup>4</sup>Assumes a City-operated composting project on UC Davis property

<sup>5</sup>Proforma does not include potential lease payments for use of UC Davis land

<sup>6</sup>Average of typical Recology JPO organics tip fees, not a City-negotiated price.

As shown, the options vary significantly in bottom line cost from roughly \$20/ton for basic composting to about \$125/ton for a more advanced project including both AD, composting, and CNG production.

Refer to *Section 7, Project Economics* of this report for details of the economic analysis.

## **GREENHOUSE GAS ANALYSIS**

As part of the expanded scope of work, the Clements team conducted a two-part greenhouse gas (GHG) analysis:

- 1) Using the U.S. Environmental Protection Agency Waste Reduction Model (WARM); and
- 2) Performing an AD Energy Balance.

The WARM analysis determined that the GHG reductions from both composting and AD were similar when compared to landfill disposal. Both achieved a GHG reduction of about 4,000 metric tons of carbon dioxide equivalent (MTCO<sub>2</sub>E) per year.

The AD energy balance took into consideration diesel, heat, and electricity requirements. It was determined that based on the City's and UCD's organic feedstocks, the batch-flow AD system could generate enough electricity to power roughly 130 residential homes, and the plug-flow AD system would produce enough CNG to fuel almost 13,000 passenger vehicles per year.

## **ADDITIONAL FINANCIAL ANALYSES**

As part of the expanded scope of work, SVM created financial proformas for three additional feedstock scenarios:

- 1) City + UC Davis Organics without City C&D;
- 2) City Organics Only; and
- 3) Four Times City Organics.

Each of these scenarios presented similar results to the original proforma developed for this project. Specifically, that the City's composting options were less expensive than the AD options, with static pile composting as the least expensive and AD-C with CASP composting as the most expensive.

As shown in these financial proformas, it is evident that a future project with City-only organics is a viable option, and possibly advantageous when compared to both YCCL and Recology JPO's estimated tip fees. However, if the City can attract more organic waste to its facility, this will decrease the facility's net cost per ton.

## RECOMMENDATIONS

Based on this report and the goals of the City, the Clements team recommends the following:

### If City Organics Only:

- #1: The City pursue a City-operated static pile composting operation at the City's WWTP.
- #2: The City pursue a City-operated CASP composting operation at the City's WWTP if greater air emission control is required by YSAQMD, or desired by the City and higher cost is not a deterrent

### If City and UC Davis Organics:

- #3: The City pursue a City-operated CASP composting operation at the City's WWTP (Option 3.B) or UC Davis (Option 4.E).

### If other organics are available:

- #4: Once composting is established and particularly if significant amounts of foodwaste are received in the future, consider the addition of AD to augment the existing composting.
- #5: Were the City able to attract organics from the region so as to increase the project capacity from 25,000 tons per year to 50,000 tons per year, favorable economics of scale could be achieved for both composting and AD alternatives.

The static pile and CASP composting options, as described above, provide organics diversion from landfill disposal, most likely avoid requiring the purchase of emission offsets, and offer carbon sequestration potential from the application of compost product. The CASP composting technology has achieved Best Available Control Technology (BACT) recognition in other air districts and provides significant air emission reductions aligned with the City's commitment to lowering its GHG emissions. CASP composting allows for the future facility to process larger quantities of organics (City plus UC Davis) and most likely remain under the offset threshold.

As shown in **Table 1.1**, the static pile and CASP composting options were the least expensive options. The UC Davis project economics may ultimately be impacted by the potential lease agreement for the City to operate on UC Davis property.

## NEXT STEPS

The team suggests the following next steps:

- Meet with UC Davis and adjacent municipalities to determine interest and commitment;
- Meet with YSAQMD to discuss BACT requirements and emission offset availability;
- Meet with Yolo County to discuss YCCL tipping fees and contract specifics;
- Meet with Recology, Inc. to determine the feasibility, tipping fee, and contract specifics of delivering organics to JPO; and
- Consider issuing an RFQ/RFP for composting vendors as the next step in implementing the preferred organics management option.

## Section 2

# Introduction and Background

The purpose of this *Organics Processing Facility Feasibility Analysis* was to provide an analysis of the current and potential future options for organic waste diversion for the City of Davis (City). Specifically, the Clements Environmental team was to determine the feasibility of a City-owned and/or operated organics processing facility at two possible locations, a County-owned and operated facility at the Yolo County Central Landfill (YCCL), a Recology-owned and operated facility, and a possible joint project with University of California Davis (UCD).

The following aspects were evaluated:

- Feedstocks
- Products Markets
- Site Features
- Technology Evaluation and Concept Layout
- Environmental Regulatory Requirements
- Capital, Operation & Maintenance, and Equipment Costs
- Policy Considerations

The City identified a need for this analysis based on current and future State of California policies and current organics processing projects moving forward in Yolo County.

The City implemented a mandatory City-wide organics program in July 2016. During the first year of its implementation (July 2016 to June 2017), the City diverted 12,674 tons of organics. These organics include mixed green and food waste, recyclable wood from construction and demolition debris (C&D), street sweepings, and loose green waste piles. Of this waste, roughly 54% is from the organics cart collection (i.e. mixed green and food waste). Recyclable wood waste from the City's C&D program may or may not be readily available for a City organics project as this waste is currently sent to YCCL's C&D processing facility. However, in the future this waste stream, residential self-haul wood waste, or another recyclable wood waste stream may become a viable feedstock and therefore some recyclable wood waste is included in this feasibility study.

The City is unique in that it has no large industrial businesses, nor does the City provide waste services to the nearby University of California, Davis. The City's largest organic waste producers are its grocery stores (i.e. Nugget Markets, Safeway, and Savemart) which have adopted individual organic waste policies and programs and, at the time of this study, did not participate in the City's organics collection. These stores have "back haul" programs where their organic waste (i.e. expired produce) are collected in the same truck that delivers their products (i.e. fresh produce).

Three major legislative mandates affect the City's organic waste: AB 341, AB 1826, and SB 1383. AB 341 sets a statewide mandate to reduce, recycle, or compost 75% of waste generated by 2020. AB 1826, which came into effect April 1, 2016, requires businesses and multifamily dwellings of certain size to divert their organic waste from the landfill. SB 1383 specifically identifies organic waste diversion targets to reduce statewide greenhouse gas emissions to 1990 levels; CalRecycle plans to adopt formal regulations by 2019 to implement these diversion goals.

The City's contracted hauler (Recology Davis; formerly Davis Waste Removal) currently collects and delivers all organics to the Yolo County Central Landfill (YCCL), where the organics are either preprocessed and transferred, or transferred directly to be composted off-site. Only one fully-permitted composting facility is located within Yolo County; Northern Recycling in Zamora. As of the date of this section of the report was completed (July 2017), all of the City-generated organics were processed at this composting facility. As of December 2017, materials from the City's organic carts are shipped to a composting facility in Napa as the Zamora facility is no longer permitted to compost foodwaste.

YCCL has developed a partnership with Northern Recycling to move the composting operation in Zamora to YCCL. In addition, during the course of this study, YCCL was permitting and constructing anaerobic composting cells and a liquid and food waste processing system at the landfill. Per discussions with Yolo County (December 2018), YCCL anticipated the first-phase of the anaerobic composting cells to be operational by January 2019. The relocation of the composting operation does not have an estimated operational date.



## Section 3

# Approach

The Clements team performed the following tasks for this analysis:

- Feedstock Study
- Products Market Assessment
- Site Assessments
- Technology Evaluation and Concept Layouts
- Environmental Regulatory Requirements
- Capital, Operation & Maintenance (O&M), and Equipment Costs
- Policy Considerations

In the course of this project, the Clements team met with representatives of the City of Davis, Davis Waste Removal, University of California Davis, Recology, Inc., and the Yolo Solano Air Quality Management District. Representatives from Yolo County were contacted via telephone.

### Feedstock Study

In July through September 2017, Clements team member, Diversion Strategies (DS), conducted a review of the City's organic waste collection routes, schedule, and programs; evaluated the City's organic feedstock tonnage and waste composition; and performed an assessment of potential organic feedstocks from the nearby municipalities of Winters, West Sacramento, Woodland, and Unincorporated Yolo County. From this information, the team was able to identify the organics feedstock quantity and quality generally available for a City organics processing facility.

### Products Markets Assessment

Diversion Strategies (DS) identified and described local and State finished compost standards applicable to this project. The team then identified potential uses for all organic products including compost and biogas. DS outlined the feasibility of marketing and distributing each end product, and identified potential outlets, uses, and pricing. In addition, the economics of utilizing the biogas for power generation and transportation fuel were evaluated.

### Site Assessments

The Clements team conducted thorough location analyses for the two sites identified by the City as potential areas for an organics processing facility. This included evaluating the sites' land availability, proximity to sensitive receptors, zoning and permitting, utility availability, and future potential uses. In addition, Clements conducted a comprehensive review of the Yolo County

Central Landfill's (YCCL) organics project including proposed operations, project status, and tip fees.

## Technology Evaluation & Concept Layout

The Clements team identified the most applicable organics processing technologies and evaluated access, land, and operational requirements. The latter included power, labor, and equipment considerations. The potential processing technologies were sized based on the City's and UC Davis's actual feedstock types and quantities. Concept site layouts were prepared depicting key functions and space requirements.

## Environmental Regulatory Requirements

Several regulatory bodies govern organics processing facilities in California including: CalRecycle, the Yolo-Solano Air Quality Management District, the State Water Resources Control Board, and the Central Valley Regional Water Quality Control Board. The Clements team has decades of experience permitting solid waste, organics and recycling facilities, and used their expertise to provide the potential impacts of regulations on the project options. Several regulatory requirements were considered in this feasibility analysis, including, but not limited to, California Environmental Quality Act (CEQA), Best Available Control Technology (BACT), National Pollutant Discharge Elimination System (NPDES) Waste Discharge Requirements (WDR), the Industrial General Permit (IGP), and Compostable Materials Handling Facilities State Minimum Standards.

## Capital, O&M, and Equipment Costs

As part of the Clements team, Sloan Vazquez McAfee (SVM) used the conceptual project design and their proprietary pro formas to identify annual and per ton project costs based on capital, and operation requirements and product revenues.

## Policy Considerations

The Clements team evaluated the advantages and disadvantages of the City's participation in each option from a policy perspective. Key among these policy issues is the balance between the effort, cost and risk of developing the City's own projects; and the loss of control and flexibility that comes with participation in a project by either Yolo County or UC Davis.

## Section 4

# Feedstock Study

### 4.1 OVERVIEW

The City of Davis, with a population of approximately 68,000 people, is adjacent to the UC Davis campus which has a student population of over 35,000 people. The fluctuation of population both seasonally and over time due to students coming and going from the University has impacts on the variation of feedstock in both volume and make up.

Due to the size of the City and the fluctuation of volume, collection vehicle routes are optimized for route efficiency and not for material type. Commercial organics accounts and residential organics accounts are picked up on the same route and co-mingled to avoid disjointed collection. If collection routes were created based on account type rather than location, vehicle miles traveled and fuel costs would increase.

The team's July 2017 feedstock composition study of the City's organic routes concluded these commingled loads of residential green/food and commercial green/food contained approximately 2-3% food waste by weight.

#### 4.1.1 Hauler

Davis Waste Removal (DWR) is a local waste hauler who has the exclusive franchise for trash, recycling and organic waste pick up in the City of Davis and parts of the adjacent unincorporated Yolo County areas. DWR has been operating in City of Davis since 1972. They collect both commercial and residential accounts for municipal solid waste, recyclables, and organics. In April 2018, Recology, Inc. (Recology Davis) acquired DWR, however this feedstock study was conducted prior to this acquisition. Since the acquisition, and at the time of this report, there have been no changes to waste collection services or routes. Therefore, the Team has left references to DWR, as appropriate, in this study. *Section 6.5* contains the evaluation for the project alternative related to Recology, Inc.

#### 4.1.2 Routes and Collection Schedule

DWR/Recology Davis operates collection routes for municipal solid waste (MSW), mixed recyclables, and organics in and near the City of Davis. The collection truck routes include both residential and commercial accounts. Routing is mapped to optimize collection efficiency and to reduce vehicle miles travelled.

Toters are used for organics collection, with food scraps, food-soiled paper, and yard materials commingled. In addition, yard materials are periodically collected loose in the street piles from customers. Collection vehicles are equipped with hydraulic arms for automated pick up. Curbside residential, commercial organics, and commercial recycling collection use an automated cart system. All trash, organics, and recyclables are placed inside the toters. MSW and organics carts are available in 95, 65, and 35-gallon sizes. MSW rates are based on the bin size and frequency of service. One organics toter per customer is included in MSW rates. Additional organics toters and/or more frequent service is available for additional cost.

Organics collection occurs Monday through Friday, with a fleet of four trucks/routes per day. The City of Davis' organics program provides for both green and food materials to be co-collected in the same bin. Most hauling routes consist of both commercial accounts and residential accounts commingled in the same truck to ensure route efficiency. Multi-family housing such as large apartment complexes are collected as commercial accounts as well as offices, retail, restaurants, and industry. Route details for organics are as follows:

- Year-Round, Monday through Friday: residential and commercial organics co-collection of green waste and food waste materials.
- Year-Round, Monday and Fridays: restaurant food waste is collected with residential co-collected organics.
- Year-Round, Tuesday: DWR collects one dedicated commercial route along with co-collected commercial and residential organics routes.
- January to October, First full week of each month: Loose green waste piles are collected. Customers are encouraged to fill their organics toter first before placing the loose green waste piles on the street for pick up.
- October to December, Weekly: Loose green waste piles are collected. Customers are encouraged to fill their organics toter first before placing the loose green waste piles on the street for pick up.
- DWR also collects green waste material from City of Davis' Parks Department (Parks Department).

#### 4.1.3 Current Organics Processing

Once collected, DWR/Recology Davis hauls the organics to the Yolo County Central Landfill (YCCL). Source-separated green materials such as the loose green waste pile pick up and material collected from the Parks Department is unloaded at the dedicated green waste area next to the Construction & Demolition Debris (C&D) area. Co-collected food and green waste materials are unloaded in a dedicated green and food organics area.

Green waste is consolidated in the green waste/C&D area by a third-party hauler and transported to Northern Recycling in Zamora, California for composting.

Likewise, the co-mingled green and food waste is consolidated in the co-mingled green and food organics area and, as of data received in July 2017, transferred by a third-party hauler to Northern Recycling in Zamora, California for composting. As of December 2018, due to the Zamora facility losing its license to compost food scraps, these materials are currently shipped to Napa Recycling's compost facility in Napa, California.

## 4.2 ORGANICS FEEDSTOCK

### 4.2.1 Tonnage from City of Davis

Tonnage from DWR's hauling data was provided by the City of Davis. For purposes of this assessment, organics tonnage beginning Third Quarter of 2016 was evaluated due to the City's expanded organics collection program beginning in July 2016.

Tonnage numbers include both residential and commercial organics, as well as street sweeping organics, recyclable wood waste from C&D debris, and green waste loose piles. Recyclable wood waste from the City's C&D program may or may not be readily available for a City organics project as this waste is currently sent to YCCL's C&D processing facility. However, in the future this waste stream, residential self-haul wood waste, or another recyclable wood waste stream may become a viable feedstock and therefore some recyclable wood waste is included in this feasibility study. Please see **Table 4.1** for a summary of the DWR hauling data.

The tonnage increase in the Fourth Quarter of 2016 can be attributed to two main factors. First, the frequency of loose green waste pile pick up increases to weekly from October to December. This quarter shows the highest amount of green waste loose pile tonnage. Secondly, the expansion of the food scrap collection program was initiated in the Third Quarter of 2016. New programs typically have a ramp up period, which seems to be consistent with the increased tonnage from the organics carts for each of the quarters.

### 4.2.2 City of Davis Feedstock Composition

In addition to the organics volumes generated and recovered in the City, the composition of this feedstock is also relevant to determining processing options.

For this feedstock study, three site visits were conducted at YCCL to view the City's different collection routes and multiple types of generators of organic feedstock. Site visits occurred midday on July 20, 2017; July 28, 2017; and August 1, 2017. John Geisler of DWR attended all three site visits; Jennifer Gilbert with City of Davis attended the site visit on July 20; and Richard Tsai with City of Davis attended the site visit on July 28. Observations of the feedstock composition on each day are described on the following pages.

**Table 4.1 DWR Hauling Data Summary**

	<i>Organics Carts (Green and Food Scraps)</i>	<i>Recyclable Wood Waste<sup>1</sup></i>	<i>Street Sweepings</i>	<i>Green Waste Loose Piles</i>	<b>Total Organics Tons Per Quarter</b>	<b>Average Tons Per Month<sup>2</sup></b>	<b>Average Tons Per Day<sup>3</sup></b>
<b>3rd Quarter 2016</b>	1,114.10	85.33	100.31	843.43	2,143.17	714	32
<b>4th Quarter 2016</b>	1,643.53	106.95	253.65	2,022.13	4,026.26	1,342	61
<b>1st Quarter 2017</b>	1,914.99	98.07	201.94	1251.5	3,466.50	1,156	52
<b>2nd Quarter 2017</b>	2,136.53	110.65	130.15	661.3	3,038.63	1,013	46
<b>TOTAL ORGANICS</b>	<b>6,809</b>	<b>401</b>	<b>686</b>	<b>4,778</b>	<b>12,674</b>	<b>1,056</b>	<b>48</b>

<sup>1</sup> Recyclable wood waste from C&D drop boxes was estimated at 15% of total C&D tonnage. This estimate was specified by CalRecycle's 2006 Detailed Characterization of Construction and Demolition Waste.

<sup>2</sup> Tons per quarter divided by 3 to determine tons per month (TPM).

<sup>3</sup> Calculated 22 business days average per mo., divided TPM by 22.

#### *YCCL Site Visit #1: July 20, 2017*

The first site visit to YCCL was conducted to view the co-collected green waste and food waste materials commingled from both residential and commercial accounts. Four collection trucks were observed unloading their route material at the dedicated green and food material receiving area of the landfill.

The co-collected wastes contained predominantly green wastes (i.e. yard clippings, branches, leaves, flowers, and dried grasses). A small amount of vegetative food wastes, food-soiled paper (i.e. paper plates and cardboard pizza boxes), non-soiled cardboard packaging, and compostable plastic bags were also present in the material. Non-organic contaminants were present, but consisted of a low percentage of the feedstock. It is estimated from visual assessment that contaminants consisted of roughly three percent (3%) of the material by weight. Common contaminants observed were film plastics, plastic bags, and plastic beverage containers. **Figures 4.1, 4.2, and 4.3** are photographs of the observed City organic waste during Site Visit #1.

**Figure 4.1 YCCL Site Visit #1, City Organics Waste Photograph #1**



**Figure 4.2 YCCL Site Visit #1, City Organics Waste Photograph #2**



**Figure 4.3 YCCL Site Visit #1, City Organics Waste Photograph #3***YCCL Site Visit #2: July 28, 2017*

The second site visit to YCCL was conducted to view the co-collected green waste and food waste materials commingled from both residential and commercial accounts. The commercial accounts on routes from this day included commercial food waste from restaurants. Three of the four collection trucks were observed unloading their route material at the dedicated green and food material receiving area on the landfill portion. A fourth truck had tipped at the dedicated green and food material receiving area prior to our arrival at YCCL. All four trucks contained food and green materials from residential and commercial accounts.

The co-collected wastes contained predominantly green wastes (i.e. yard clippings, branches, leaves, flowers, and dried grasses), but had a visible increase in the amount of food waste content compared to Site Visit #1. Food waste was recognizable and consistent with commercial restaurants, including a bag of flour, loaves of bread, bags of discarded bagels, and popcorn from the local movie theater. Vegetative food wastes along with food-soiled paper (i.e. paper plates and cardboard pizza boxes), non-soiled cardboard packaging, and compostable plastic bags were also present in the material. Contamination was visibly higher, but still consisted of a low percentage of the feedstock. It is estimated from visual assessment that contaminants consisted of roughly seven percent (7%) of the material by weight. Common contaminants observed were film plastics/plastic bags (non-compostable), plastic and glass beverage containers, and foamed plastic and canned food containers from households. **Figures 4.4, 4.5, 4.6, and 4.7** are photographs of the City organic waste observed during Site Visit #2.



During this site visit at the YCCL, the dedicated green waste area adjacent to the C&D area was also observed. Material in this area consisted of leaves, grass and branches and had very little, if any, visible contamination. **Figure 4.8** is a photograph of the YCCL green waste area.

**Figure 4.4** YCCL Site Visit #2, City Organics Waste Photograph #1



**Figure 4.5** YCCL Site Visit #2, City Organics Waste Photograph #2



**Figure 4.6** YCCL Site Visit #2, City Organics Waste Photograph #3



**Figure 4.7** YCCL Site Visit #2, City Organics Waste Photograph #4



**Figure 4.8 YCCL Site Visit #2, YCCL Green Waste Area Photograph #1***YCCL Site Visit #3: August 1, 2017*

The August 1<sup>st</sup> site visit to YCCL was conducted to view a dedicated commercial organics route operated by DWR. The commercial accounts on this route were downtown commercial businesses and offices.

The dedicated commercial route contained predominantly green wastes (i.e. yard clippings, branches, leaves, flowers, and dried grasses). Some food wastes were observed, although in not as high a concentration as Site Visit #2. Food waste was recognizable and appeared to be mostly scraps and vegetative food wastes. A high amount of food-soiled paper (i.e. paper plates and cardboard pizza boxes) was present in the feedstock along with non-soiled cardboard packaging and some compostable plastic bags. Contamination within the feedstock was the highest of the three site visits, estimated to be roughly ten percent (10%) by weight. Common contaminants observed were film plastics/plastic bags (non-compostable), plastic and glass beverage containers, foamed plastic and canned food containers from households. Household garbage, including electronics, and office break room garbage were observed in the loads. **Figures 4.9 and 4.10** are photographs of the City's organics waste from Site Visit #3.

**Figure 4.9** YCCL Site Visit #3, City Organics Waste Photograph #1



**Figure 4.10** YCCL Site Visit #3, City Organics Waste Photograph #2



*YCCL Site Visit by DWR: August 7, 2017*

John Geisler of DWR provided photographs of the collected feedstock from a dedicated commercial partial route that operated on August 7<sup>th</sup>. The load contained cardboard, food, and compostable plastic bags. According to Mr. Geisler, this commercial route includes the Davis Food Co-op, and contained the highest amount of food observed during any of the site visits. **Figure 4.11** is a photograph taken by DWR during DWR's YCCL Site Visit.

**Figure 4.11** YCCL Site Visit by DWR, City Organics Waste Photograph #1  
(Source: DWR)

*Organics Cart Feedstock Composition Summary*

The food and green commingled feedstock observed on the three site visits and the photographs provided by DWR consistently showed a high content of green waste with approximately two to three percent food waste, and three to ten percent contamination. The City's commingled organics cart program has shown an increase in every quarter since the beginning of the program in July 2016. We would expect the percentage of food waste to increase over the months and years as the residents and businesses in Davis grow accustomed to the program, gain proficiency in the source separation tasks, and as even more stringent organics recovery legislation is passed in the future. This assumption is based on the team's observation of waste composition of other, existing municipal organics and recycling programs.

### *City of Davis Wastewater Treatment Plant*

As of July 2017, the City Wastewater Treatment Plant (WWTP) sends its biosolids to YCCL for use as Alternative Daily Cover (ADC) at a tip fee of \$20 per ton. The WWTP has recently installed secondary and tertiary treatment site improvements. The installation was still underway at the time this portion of the study was completed, so it was not clear as to the exact quantity of biosolids from the City WWTP that would be available for a potential organics processing facility. From the City's WWTP improvement plans dated April 2015, the maximum amount of dry solids expected from the WWTP is 8,040 pounds per day. Using a 365-calendar year, this equates to roughly 4 TPD or 1,467 TPY. For purposes of this study, it was assumed that the City would continue sending its biosolids to the YCCL for use as ADC into the foreseeable future as the \$20 tipping fee and the simplicity of the program are very beneficial.

#### 4.2.3 Other Feedstocks

##### *Yolo County Organics*

Yolo County is a predominantly agricultural county. The Yolo County seat is located north of Davis, in Woodland. Other cities in Yolo County include West Sacramento and Winters. **Table 4.2** shows the estimated theoretical breakdown of annual organics generation within Yolo County.

DWR/Recology Davis is the hauler for the City of Davis, and a portion of unincorporated Yolo County. Waste Management, Inc. (WMI) is the hauler for the cities of Woodland, West Sacramento, and Winters, and the other portion of unincorporated Yolo County. WMI takes their collected material to YCCL.

The City of Davis began co-collecting residential green and food waste in July 2016. The City of Winters started a similar program in July 2017, the City of West Sacramento in January 2018, and the City of Woodland in March 2018.

Since 2014, programs have been put in place at both the state and local level to increase organics diversion from landfills (see *Section 5. Organics Waste Composition Variables* for more detail). It could be expected that the amount of organics separated from the disposal stream has increased since 2014. Updated data should be presented from the state this calendar year as CalRecycle began a 2018 Waste Characterization in February 2018 to analyze progress towards state goals. The data from this waste characterization study is expected to be released in the fall of 2019.

##### *Commercial Organics*

In addition to common commercial businesses such as retail shops, restaurants, and offices, Yolo County is home to commercial food processing plants and wineries. According to the Yolo County

May 2019

**Table 4.2 Yolo County Theoretical Organics Generation**  
(Source: 2014 CalRecycle Waste Characterization)

JURISDICTION	WASTE TYPE	TPY	TOTAL TPY
Davis	Total Commercial <sup>1</sup> Organics	11,921 TPY	20,507 TPY
	Total Residential <sup>2</sup> Organics	8,586 TPY	
Woodland	Total Commercial <sup>1</sup> Organics	13,484 TPY	20,828 TPY
	Total Residential <sup>2</sup> Organics	7,344 TPY	
Winters	Total Commercial <sup>1</sup> Organics	1,027 TPY	1,966 TPY
	Total Residential <sup>2</sup> Organics	939 TPY	
West Sac	Total Commercial <sup>1</sup> Organics	17,541 TPY	24,382 TPY
	Total Residential <sup>2</sup> Organics	6,814 TPY	
Unincorporated Yolo County	Total Commercial <sup>1</sup> Organics	4,127 TPY	6,638 TPY
	Total Residential <sup>2</sup> Organics	2,511 TPY	

<sup>1</sup> Commercial organics wastes are generated by businesses, industries (e.g., factories, farms), institutions, and public areas (e.g., roads, parks). Commercial estimate on the types and amounts of materials in the waste streams of California jurisdictions based on statewide average data collected in recent CalRecycle studies that is then combined with local employment or housing data.

<sup>2</sup> Residential organics wastes are generated by households, consisting of both single family residential and multi-family that includes four or less units. Residential estimates are based on statewide data collected in recent CalRecycle studies that is then combined with local housing and population data.

General Plan, this includes one tomato processor, two rice mills, nine wineries, eight nut and nut oil processors, three dairies, 16 seed labelers, and a prune processor.

Yolo County contains several vineyard areas in Clarksburg, Winters, and Capay/Dunnigan Hills. In 2015, Yolo County vineyards produced 28,612 tons of red wine grapes and 62,341 tons of white wine grapes. Winery wastes are high-liquid with a solid content consisting of grape pomace (seeds, skins and stems) and lees. Generally one ton of pomace is produced from every five (5) tons of grapes crushed.

Food processing and winery wastes can be managed in a variety of ways. Some material might go to disposal, however, these organics can also go to land application, reuse on site, waste water treatment plants, animal feed, composting (both on-site and commercial scale), and a small volume may go to the UC Davis anaerobic digester. Availability of this material for a City project would depend on factors such as local franchise agreements, pricing, and local/regional/state regulations.

University of California, Davis

Waste generated at UC Davis (UCD) is collected and managed by the University and includes green and food wastes as well as animal bedding and manure. The organic feedstock generated by UCD that may be available for a potential City organics processing facility, as identified by UCD in August 2017, is broken down by material type in **Table 4.3**.

**Table 4.3 Estimated UCD Available Organics Tonnage**

MATERIAL	AVERAGE ANNUAL TONNAGE	TONS PER DAY <sup>1</sup>	FINAL DESTINATION
Food Waste (postconsumer) <sup>2</sup>	150	0.5	Northern Recycling Compost Facility in Zamora
Animal Science Bedding (60% manure)	8,000	30	Green Belt Carrier composting facility in Dixon, CA <sup>3</sup>
Straw, Shavings & Manure	3,000	11	California Soils composting facility in Vernalis, CA
Green Waste	1,250	5	YCCL
Biosolids	400	1.5	YCCL
AD <sup>4</sup> digestate	528	2	Not confirmed.
<b>TOTAL ORGANICS</b>	<b>13,328</b>	<b>50</b>	

<sup>1</sup> Daily tonnage based on 22 working days per month rounded to the nearest half.

<sup>2</sup> Waste audits at the Coffee House (which accounts for half of the material stream) consistently has shown less than 10% contamination by weight. The audits do not consider PLA or bioplastics as contamination.

<sup>3</sup> Any tonnage not removed by Green Belt Carrier is stockpiled on UCD property.

<sup>4</sup> The UCD AD system also produces 10,000 gallons per day of wastewater

In 2015, CleanWorld constructed and began operating an AD system on UCD property to manage organic feedstocks from the campus. UCD purchased the digester in August 2017. The original design capacity of this digester was to process up to 50 tons per day (TPD) of organic waste at an average of 25 percent solids. During the digester's operation under CleanWorld's ownership, the system typically operated at 60 percent capacity, processing approximately 30 TPD of pre-consumer food from UCD, produce wastes from private food distribution companies, tomato wastes, and ice cream wastes. Although this AD system is considered a high-solids AD, greenwaste is not a viable feedstock as it would significantly exceed the ideal solids range for this facility. Thus, the UCD AD system is not a viable outlet for the City as the City's organic waste is predominately greenwaste. This is also the reason why UCD has available feedstocks for a City organics project as these materials are not accepted by the University's digester.



### 4.3 ORGANIC WASTE COMPOSITION VARIABLES

Policy at both the state and local level can influence the quantity and composition of feedstocks as programs mature. Both the State as well as the City have established aggressive programs geared towards diverting organics from disposal.

#### 4.3.1 City of Davis Organics Programs

In June 2016, the City implemented a food scrap collection program whereby both residents and businesses within the City can put their green and food wastes in the organics carts for pick up by DWR. Being only a year old at the time of this portion of the study, the program was still in a ramp up phase. From when the program started (July 2016) to a year later, tonnage within the carts has continued to increase each quarter despite the population characteristics and seasonal fluctuations in the number of students in residence at UCD.

The City continues education efforts including providing information to residents on the program and having DWR perform waste audits on local businesses. Based on the team's experience of established organics programs, five percent (5%) food content in residential organics and ten percent (10%) food content in commercial organics would be an optimistic but achievable near term goal, which may likely rise in future years as the program matures.

#### 4.3.2 State of California Policy

California has a long history of encouraging robust recycling programs by passing legislation and mandates that require local government to meet aggressive recycling targets. Once the foundation was set by AB 939, which mandated that cities and counties divert at least 50% of their solid waste from landfills by the year 2000, the Integrated Waste Management Act continued to be amended to foster ever more aggressive recycling programs across the State. While AB 939 focused mainly on traditional recyclables found in "blue bin" programs as well as construction and demolition wastes, subsequent legislation requiring organics collection and diversion have emerged in the last five years. Relevant policies that pertain to organics diversion from landfills are detailed below. These current policies, paired with the more aggressive recycling goals and mandates coming from the state and local levels is expected to have a positive effect on the City's organic waste generation, recovery, and potential for a processing facility.

#### *SB 1383*

SB 1383 (Short Lived Climate Pollutants) includes a component that establishes targets to achieve a 50 percent reduction in the level of the statewide disposal of organic waste (from the 2014 level) by 2020 and a 75 percent reduction by 2025. The bill was signed by the Governor in October 2016, and CalRecycle is currently drafting regulations. At the time of this report, the rulemaking

*May 2019*

process is in the preliminary, informal workshop stage, with formal rulemaking expected in 2018 and adoption of the new regulations by the end of 2019.

#### AB 1826

AB 1826 (Mandatory Commercial Organics Recycling) requires businesses and multifamily dwellings to recycle their organic waste on and after April 1, 2016, depending on the amount of waste they generate per week. The bill was signed by Governor Brown in October 2014. 1826 provides for a phased approach, increasing the thresholds for generators to comply over the course of several years. 2017 was the first year under the bill that jurisdictions must report information to CalRecycle about their organic waste recycling program implementations. The annual reports were due to CalRecycle on August 1<sup>st</sup>.

## 4.4 CONCLUSION

Based on this information, the team is designing the conceptual organics facility for the following feedstocks shown below in **Table 4.4**. **Tables 4.5, 4.6, and 4.7** categorize the available organics that could be utilized in the alternative projects evaluated in this study.

For the purposes of this feasibility assessment, the Team has eliminated the biosolids from the City's and UCD's wastewater treatment plants as potential feedstocks. This is due to the fact that both treatment plants have very favorable current programs whereby the biosolids are used for ADC at the YCCL, and also because the inclusion of biosolids negatively effects the potential market for the final compost product.

**Table 4.4 Available Organic Feedstocks Summary**

	Green Material (TPD) <sup>1</sup>	Food and Commingled Food/Green (TPD) <sup>1</sup>	Other Organics (TPD) <sup>1</sup>	TOTAL TPD <sup>1</sup>	TOTAL TONS PER YEAR
<b>City of Davis</b>	18.0	26.0	4.0 <sup>2</sup>	48	12,672
<b>UC Davis</b>	5.0	0.5	43.0 <sup>3</sup>	48.5	12,804
<b>Total</b>	<b>23.0</b>	<b>26.5</b>	<b>47.0</b>	<b>96.5</b>	<b>25,476</b>

<sup>1</sup> Tons per day (TPD) is based on 22 working days per month

<sup>2</sup> Other organics is the combined City wood waste from C&D drop boxes and street sweepings

<sup>3</sup> Other organics is the combined UCD animal manure and bedding, and AD digestate

**Table 4.5 Available Organic Feedstocks for Stand-Alone Composting**

City of Davis		Tons per Day <sup>1</sup>	% Contamination
	Mixed Green and Foodwaste <sup>2</sup>	26	< 10%
	Greenwaste (loose)	18	0%
	Other Organics <sup>3</sup>	4	0%
<b>City Total Organics:</b>		<b>48</b>	
UC Davis		Tons per Day <sup>1</sup>	% Contamination
	Postconsumer Foodwaste	0.5	< 10%
	Greenwaste	5	
	UC Digestate	2	
	Animal Manure & Bedding	41	
<b>UC Davis Total Organics:</b>		<b>48.5</b>	
<b>TOTAL COMPOSTING FEEDSTOCKS:</b>		<b>96.5</b>	

<sup>1</sup> TPD based on 22 working days per month.

<sup>2</sup> Residential and commercial green/food contain approximately 2-3% foodwaste by weight.

<sup>3</sup> Other organics is the combined City woodwaste from C&D drop boxes and street sweeping.

**Table 4.6 Available Organic Feedstocks for Anaerobic Digestion**

City of Davis		Tons per Day <sup>1</sup>
	Mixed Green and Foodwaste	26
	Greenwaste (loose)	18
	Other Organics <sup>2</sup>	4
<b>City Total Organics:</b>		<b>48</b>
UC Davis		Tons per Day <sup>1</sup>
	Postconsumer Foodwaste	0.5
	Greenwaste	5
<b>UC Davis Total Organics:</b>		<b>5.5</b>
<b>TOTAL AD FEEDSTOCKS:</b>		<b>53.5</b>

<sup>1</sup> TPD based on 22 working days per month

<sup>2</sup> Other organics is the combined City street sweeping and woodwaste from C&D drop boxes

**Table 4.7 Available Organic Feedstocks for Composting with AD**

City of Davis AD System		Tons per Day <sup>1</sup>
	Digestate (75% of AD feedstocks) <sup>2</sup>	40.13
<b>City Total Organics:</b>		<b>40.13</b>
Non-Digestable Organics		Tons per Day <sup>1</sup>
	UC Digestate	2
	Animal Manure & Bedding	41
<b>UC Davis Total Organics:</b>		<b>43</b>
<b>TOTAL COMPOSTING FEEDSTOCKS:</b>		<b>83.13</b>

<sup>1</sup> TPD based on 22 working days per month

<sup>2</sup> This is the average digestate production between both types of AD systems reviewed in this study.

## Section 5

# Products Market Assessment

### 5.1 INTRODUCTION

This section provides an overview of the markets for the key products and by-products of possible organics infrastructure. Most importantly for this study, these products include compost from a composting operation, and biogas from an AD system.

### 5.2 FINISHED COMPOST QUALITY

Finished compost appears as a dark brown, soil like humus with an earthy smell. Title 14, Chapter 3 of the California Code of Regulations (“regulations”) establishes standards for the compost product. Key components to finished compost quality are:

1. Pathogen reduction
2. Metals concentrations
3. Physical contaminants

Finished compost will have gone through a pathogen reduction process during its active composting phase, reaching temperatures of over 55 degrees Celsius (131 degrees Fahrenheit) for a period of at least three days during this active composting phase. The length of time will vary dependent on the composting process used (in-vessel, open windrow, aerated static pile, etc.). The finished product must meet requirements for maximum acceptable pathogen concentrations for Salmonella and fecal coliform as outlined in the regulations.

Finished compost product must also meet maximum acceptable metals concentrations as outlined in the regulations. Metals include: Arsenic, Cadmium, Chromium, Copper, Lead, Mercury, Nickel, Selenium, and Zinc.

Physical Contamination of the finished compost product is also limited by the regulations. Finished product cannot contain more than 0.5% by weight of contaminants greater than 4 millimeters, and no more than 20% of that 0.5% can be film plastic greater than 4 millimeters.

Testing and sampling occurs during and after the composting process to ensure these standards are met prior to removal of the compost from the facility.

A blend of carbon and nitrogen is essential for the composting process. Grasses and green wastes such as leaves, along with food wastes and biosolids contain more nitrogen while more fibrous sources such as wood chips, branches, dried leaves, dried grasses, and straw provide a higher carbon content. Having a balanced ratio of carbon and nitrogen is a necessary component for the

composting process to maintain aerobic conditions within the compost pile and sustain microbial activity.

Temperatures reached during pathogen reduction should be sufficient to kill off weed seeds. If the compost product has reached desired temperatures of over 55 degree Celsius for a period of time during the active composting process, it is unlikely that weed seeds will survive and be passed on in the finished compost product.

### **5.3 AMENDMENTS**

Compost additives can be incorporated into the compost process to provide nutrients (including carbon and/or nitrogen), aid in pile porosity, aid in moisture control, achieve desired PH levels, and aid in minimizing nuisance conditions such as leachate and odors. Common amendments to the compost process include: wood chips, straw, shredded paper, sawdust, rice hulls, manures, and gypsum.

Materials found in recycling streams such as paper, yard material, clean construction & demolition (C&D) waste, and clean wood waste can be used as amendments. However, it should be determined if use of these materials as an amendment is the highest and best use as compared to reuse or manufacturing a new product for the market.

Food soiled paper is good feedstock for composting since it cannot be recycled. Clean paper (including printed) can also be used as an amendment, but should be evaluated if use as an amendment is the highest and best use of material as compared to a conventional paper recycling process. Some paper such as newsprint can contain a high lignin content which can be resistant to decomposition. Inks should not pose an issue for a compost amendment although many composters do try to avoid including substantial amounts of paper with ink on it. Most newspapers nowadays use water or soy-based inks, however glossy magazines do sometimes use heavy metal-based inks.

As indicated above, yard materials such as branches, dried grasses, leaves, and straw provide a good carbon source for compost. In addition, agricultural sources such as orchard waste can be used as a carbon source as well. These materials not only add carbon, but also increase porosity and aeration as well.

Ground wood waste also provides a good carbon source. Again, it should be evaluated if use as an amendment is the highest and best use for clean wood and clean C&D. Reuse and processing clean wood as a mulch product provides a quicker production time and faster path to market. In addition, processing clean C&D and clean wood into an amendment would require processing, which increases handling, equipment requirements, manpower and cost.

The use of amendments in the anaerobic digestion process is dependent on the technology chosen. Generally, food material as a feedstock provides for a higher energy offtake than green/wood feedstocks in the digestion process. However, these amendments can be used for the composting of digestate following the AD process.

## 5.4 FINISHED PRODUCT USES AND MARKET ASSESSMENT

Diverting organics away from the landfill to other management options introduces new products and byproducts into the marketplace. Several products and commodities can be generated from the composting and digestion processes. While some, like compost and biogas, can be revenue generating, others such as leachate and digestate can be an expense to the operation depending on how it is managed.

### 5.4.1 Revenue Generating Byproducts of Organics Management Options

#### *Compost*

The City of Davis is located in an optimal geographic location for the sale of compost and compost products. Not only is Davis surrounded by agricultural land, but many crops grown exclusively in the area are regular consumers of compost products. Over the last several years, water use restrictions tightened due to drought conditions in California. As a result, the water retention capabilities of compost attracted both big and small agriculture to invest the time and money associated with compost application over the last several years.

California has made a large investment in composting in the form of the Healthy Soils Initiative. Governor Brown's office included funding of \$25 million to support a statewide "soil carbon" program, aimed at providing financial incentives for farmers and ranchers to implement soil management and agricultural practices that sequester carbon and improve soil health, including increasing the carbon/organic matter of soils through the use of compost. Key state agencies are considering setting a soil carbon target, where the State would attempt to increase soil carbon levels by one to five percent over the next three to five years. Compost use is considered one of the best ways to return organic matter to the soil and cultivate soil health quickly. This initiative is currently being administered by the California Department of Food and Agriculture (CDFA), in collaboration with various state agencies and departments, and is thought to be a program that will enhance the marketability of compost in the state.

One of the key limiting factors for marketing compost is haul distance. For most crops, the margins only allow for the cost of hauling the compost up to 50 miles. This haul distance varies based on: volume of product purchased, crop profit margin, and value of compost product (100% compost vs specialized blend, etc.)

### **Potential Volume of Marketable Compost Product Available**

Based on the assessment of the City of Davis' organic feedstock, if the City were to divert all of its current material to a new composting facility, it would result in an approximate amount of 12,000 to 13,000 tons of feedstock/year. For UCD, the similar organic feedstock is also about 13,000 TPY. Conditions such as contamination level, screen size, and biological activity greatly influence how much compost can be produced from one cubic yard (cy) of municipally-derived food/yard waste compost. For the purposes of this study, the following factor was used: for every one ton of feedstock, approximately two-thirds or 0.67 ton of compost can be manufactured and sold. This conversion factor was based on data from an active, organics windrow composting operation in California. Therefore, it is estimated that the annual amount of compost manufactured including both the City and UCD material is about 17,000 tons. This equates to 28,000 cy assuming a compost density of 1,200 lbs per cy.

### **Potential End Users of Compost and Compost Products**

#### ***Bulk Agricultural Sales:***

Compost manufacturing is similar to other manufacturing where inventory control is important to keeping operations running smoothly. One way to ensure compost is sold and moved quickly is through bulk sales to large agricultural operations in the region.

The top 10 crops as of 2012, ranked by highest revenue per acre, in the Yolo/Solano/Sacramento are shown in **Table 5.1**. Of these top 10 crops, six are compost users within a reasonable hauling distance from the City of Davis. While box tree nursery operations do not represent a large acreage, they have been avid purchasers of compost and mulch products. Bartlett pears, almonds, walnuts, and wine grapes represent over 100,000 acres of cropland that regularly use and benefit from agronomic application of compost and compost blends.

For most crop producers, hauling distance is a significant limiting factor, which is why we have chosen to limit the market area to Yolo, Solano and Sacramento Counties. However, some crops defy this industry norm. Cannabis farmers, for example, operate on high revenue per acre and have unique custom compost blend needs. This allows cannabis producers to haul custom blends longer distances to ensure a highly stable, uncontaminated product.



**Table 5.1 Top 10 Crops in the Yolo/Solano/Sacramento Region**

COMMODITY	HARVESTED ACRES	REVENUE	REVENUE / ACRE	YEAR	COMPOST USER?
Nursery	2,589	\$50,925,000.00	\$19,669.76	2015	Y
Bartlett Pears	5,072	\$39,893,000.00	\$7,865.34	2015	Y
Almond	27,988	\$116,053,000.00	\$4,146.53	2015	Y
Tomatoes	48,978	\$181,291,000.00	\$3,701.48	2015	N
Walnuts	25,981	\$81,245,000.00	\$3,127.09	2015	Y
Wine Grapes	48,951	\$143,192,462.00	\$2,925.22	2015	Y
Rice	31,260	\$50,854,000.00	\$1,626.81	2015	N
Sunflowers	30,385	\$42,963,000.00	\$1,413.95	2015	N
Organic Production	42,656	\$51,173,000.00	\$1,199.67	2015	Y
Hay	79,401	\$84,622,000.00	\$1,065.75	2015	N

\*All data pulled from County Crop Reports written by County Ag Departments reported annually.

### ***Pricing for Bulk Compost Sales***

In the region around the City of Davis, bulk compost typically sells for between \$12 and \$25 per cy depending on the volume sold and whether or not the compost is Organic Materials Review Institute (OMRI) listed, and/or certified organic. Compost used for organic production can yield a price closer to \$25 per cy while non-organic, raw compost can sell for as low as \$10 to \$12 per cy.

Using an average density of 1,200 pounds per cubic yard of compost, the average price per ton of compost is \$20 to \$40 per ton depending on certification, quality, and volume.

### ***Bagged Compost Products***

One way to maximize the profit per ton of compost is by offering a bagged product to retailers in the region. Bagged products yield a higher price per ton of compost, but require more equipment and labor to produce, as well as increased distribution channels leading to more customers and customer service requests.

One way to avoid the increased equipment, labor, and customer service demands of manufacturing bagged product is by partnering with an agricultural bagging service like E.B. Stone in Suisun City. Such an arrangement is a win-win scenario because the partner without a bagging system is able to increase sales potential by offering a bagged product, and the bagging contractor can optimize the use of its bagging system while also generating new revenue for the company.

The average price for bagged compost is \$6.00/ft<sup>3</sup> of product which is equal to approximately 40 pounds. Using the estimated volume of roughly 17,100 tons of potential manufactured compost, as outlined on Page 31, from the combined City and UCD organic feedstocks, this would result in approximately 855,000 bags of compost. Based on the consulting team's knowledge of the composting industry and local markets for the product, we believe the City can realistically sell 100% of their marketable product, and using the average price for bagged compost of \$6.00 a bag this results in \$5.13M gross revenue annually from the sale of bagged compost. Although this amount might look enticing compared to bulk agricultural sales, it comes with significant expense in: quality control, labor, bag cost, equipment cost and maintenance, marketing, and customer service requirements. For the purposes of the Financial Pro Forma included in **Appendix D**, the average price per ton of bulk compost product was used.

### ***Compost Give-a-ways***

Local community give-a-ways provide a good outlet for the finished compost product, while supporting and giving back to the local community. While compost give-a-ways may not generate monetary revenue, they generate goodwill as well as educating the public on the benefits of local organic programs. Typically, programs such as this are staffed by volunteers, and local companies may volunteer transportation of the product from the compost site to the give-a-way location, so monetary costs of executing such a program are low.

### **Compost Blends**

One way to maximize both the economic and environmental impact of manufacturing compost is by offering custom blending for many different applications. Custom compost blending not only maximizes the profitability of selling compost, it opens additional market opportunities.

Compost can be blended with soil, or other amendments such as gypsum, lime, worm castings, bat guano, feather meal, and other additives for specific application in niche markets. Market opportunities for compost blends in Yolo County range from wetland restoration to serving the growing cannabis farming community. For these high-level potential uses, it is likely the compost purchaser would be companies hired to do the actual work (e.g. contractors).

Wetland Restoration: Given Yolo County’s large wetland footprint, using a compost and soil blend for wetland restoration is one way to market compost in the area. Rich in organic matter, and microbial populations, a soil and compost blend mimics the characteristics of wetland soil which can help spur growth of native plant species.

Cannabis Production: With the legalization of the cultivation and sale of cannabis, California expects the cannabis market to have a value of around \$7 billion once the legal market is established. With legalization comes regulation, and meeting requirements for pesticide levels in cannabis will likely steer cannabis farmers toward more sustainable farming practices, including using compost blends to optimize soil and plant health.

Much like the trend in viticulture, cannabis farmers are growing a wide variety of plant types, each requiring slightly different growing conditions for optimal production and potency. This lends itself to opportunities for marketing highly customized blends to end users in this market.

**Table 5.2** shows some common additives, their approximate cost, and potential for profit.

**Table 5.2 Costs for Common Compost Amendments**

Common Compost Amendment	Approx. Cost / Ton of Amendment	Compost Price/ton <sup>2</sup>	Operating Cost/ton <sup>3</sup>	Profit Margin/ton @ 25%	Profit Margin/ton @ 35%
Bat Guano	\$500	\$20	\$4	\$131	\$183
Dolomite	\$47	\$20	\$4	\$18	\$25
Feather meal	\$400	\$20	\$4	\$106	\$148
Potassium Sulfate	\$145	\$20	\$4	\$42	\$59
Sulfur	\$225	\$20	\$4	\$62	\$87
Worm Castings	\$350	\$20	\$4	\$94	\$131
Gypsum	\$40	\$20	\$4	\$16	\$22
Lime	\$15	\$20	\$4	\$10	\$14
Perlite	\$30	\$20	\$4	\$14	\$19

<sup>1</sup>Approx. cost/ton of additives found on global trade site alibaba.com and based on data available at time of report

<sup>2</sup>Compost price/ton is based on market area’s average price/ton of compost

<sup>3</sup>Operating cost/ton based on industry knowledge of market area operating cost/ton of compost blend

It is evident that adding custom blending to any compost operation can greatly increase the revenue from the back end of the compost operation, which will in turn allow the facility to rely less on tip fees as a means of cash flow.

### **Mulch and Landscape Products**

One way to greatly enhance the marketability of a site's feedstock is to ensure the material is managed in the most economically favorable way by assessing the value stream of each incoming feedstock. Dimensional lumber and wood pallets are considered organic, but may have a higher and better use than as an added carbon source for the composting process.

A potential product from processing dimensional lumber and wood pallets is mulch. Mulch is a rapidly growing niche in the California landscape market due to an increased awareness of water use reduction practices. Replacing both residential and commercial lawns with drought resistant landscapes has been a common practice with residents and businesses alike over the past five years as California struggles to reduce water consumption.

Outdoor landscaping is the single largest use of water in the typical California home. In most yards, grass consumes the most water, so reducing or eliminating grass in landscapes can make a significant impact on the State's water use.

Governor Brown issued an Executive Order on April 1, 2015 that directed the implementation of specific actions to reduce potable water use in the urban sector. Directive number three declared that 50 million square feet of turf be replaced with drought-tolerant landscapes, such as mulch. This is to be accomplished by local water agency programs and a complementing statewide residential turf rebate program implemented by Department of Water Resources.

In order to manufacture drought-tolerant landscape products, such as mulch, the City would have to invest in a grinder and coloring machine to correctly size the product and prepare it for sale into the marketplace. Alternatively, some industrial applications such as sheet mulching will only require size reduction of dimensional lumber and wood pallets, unlike landscaping application which requires more stringent specifications such as color and zero contamination tolerance. While landscape mulch yields a higher price in the marketplace, sheet mulching is a less labor and capital intensive way of getting this recycled product into the marketplace for a higher and better use.

### ***Potential Volume of Marketable Mulch and Landscape Products***

Recyclable wood waste from the City's C&D program may or may not be readily available for a City organics project as this waste stream is currently sent to YCCL's C&D processing facility. However, in the future this waste stream, residential self-haul wood waste, or another recyclable

May 2019

wood waste stream may become a viable feedstock and therefore some recyclable wood waste is included in this feasibility study.

Based on the feedstock assessment of the City of Davis' organic feedstock, the available dimensional lumber and wood pallets in the City's waste stream (15% of material from C&D drop boxes) is estimated at 401 tons per year. Taking into account volume reduction as a result of losing fines from grinding, it can be assumed that 90% of the dimensional lumber product can be sold as marketable product. The City of Davis would have approximately 261 tons of marketable mulch product available for sale annually.

### **Distribution Models for Compost**

Compost distribution from facility to end user can take on several different models, including: partnering with a bagging operation, distributing through an agricultural products broker, purchasing delivery trucks and equipment like spreading machines, finding customers that prefer to handle the logistics of compost pick-up and delivery. However, given the expected volume of compost produced by the City, the models that make the most economic sense for the City are:

- Sell compost to a compost broker at a reduced rate
- Establish facility's own customer base for bulk agricultural sales with customers that handle their own logistics for delivery of compost; and
- Establish facility's own customer base for bulk agricultural sales and contract with third party haulers to distribute compost to customers.

#### ***Distributing through brokers***

Distributing compost through brokers is a good way to ensure product is moving from production to inventory to market quickly, with minimal expense to the compost manufacturer. This is an ideal situation if the City is not interested in hiring additional staff to both sell the compost and service the end user. Contracts with one or more agricultural products brokers can be negotiated for 100% or less of the overall compost volume.

Gross revenue from compost sales will be much less with this option since brokers are only willing to pay a fraction of the average per ton price for compost. However, most of the product revenue will be profit since there is limited operational costs associated with this distribution model besides the labor and equipment costs associated with loading the compost into transfer trucks for distribution.

#### ***Distributing through third-party haulers***

Contracting with third party haulers to distribute compost product to customers is another option for distributing City compost product. In this scenario, the City would incur the time and expense

May 2019

of customer acquisition as well as customer service, but would contract out the hauling and delivery of the compost product to third party hauling services. The cost of hauling and delivery of the compost product would be returned to the City through additional fees to the end user meant to cover these costs. In addition, the City could charge a small profit margin for the service of facilitating the logistics of delivery.

This model is a good option if the City is interested in selling compost at its full market value while maintaining control of the product's brand. Gross revenue from compost sales will be higher than under the broker model, however, more staff time will be dedicated to attracting and servicing customers.

### ***Scheduled pick-ups by customers***

Another option for compost distribution is to limit the City's customer base to end users with logistical functions that prefer to pick up, haul and deliver compost using their own trucks. This model allows for reduced costs associated with scheduling and negotiating rates with third party haulers while still maintaining a decent profit margin. One thing to consider with this distribution model is that it seriously narrows the type of customer the City can do business with. This focused sales effort can result in acquiring customers with a need for large volumes of compost. This model carries considerable risk since the customer base is likely to be less diversified and losing one customer can result in unsold inventory.

This model is a good option if the City can secure long term agreements with end users in close proximity to the compost site.

### **Competitors in Region**

The two main competitors in the region are Recology Jepson Prairie Organics located in Vacaville, CA and Northern Recycling located in Zamora, CA.

- Recology averages approximately \$12 per cy bulk raw compost (\$20/ton)
- Northern Recycling advertises \$18 per ton bulk raw compost

Although the region's main competitors are close by, due to the agricultural nature of the region, the market is not saturated, and market penetration should not be a problem with a quality product.

#### **5.4.2 Anaerobic Digestion and Biogas Projections**

##### ***Anaerobic Digestion Process Description and Selection***

The organic waste anaerobic digestion industry is relatively young. While a limited number of facilities were installed in the 1980s, the industry's rapid growth did not begin until the mid-1990s.

May 2019

Given that the industry is merely three decades old, it is no surprise that there are many different anaerobic digestion (AD) technologies available. Another reason for the variety in process types is the wide range of feedstocks processed. Organic waste feedstocks differ substantially, from unsorted municipal solid waste (MSW) to homogenous industrial food wastes, to curbside-collected green waste. Anaerobic digestion technologies can be categorized based on the following features:

- Number of stages
  - Single-Stage
  - Two-Stage
- Feed Total Solids (TS) content
  - “Wet”/Low solids process (<15 – 20 percent TS)
  - “Dry”/ High-solids process (>15 – 20 percent TS)
- Operating temperature
  - Mesophilic (approximately 93 to 98 °F [34 to 37 °C])
  - Thermophilic (approximately 131 to 140 °F or [55 to 60 °C])
- Agitation
  - Gas injection
  - Internal mechanical components (agitator)
  - Re-pumping / Re-circulation
- Reactor / Digester type
  - Vertical positioning
  - Horizontal positioning
- Process flow
  - Continuous (fully mixed or plug flow)
  - Discontinuous (batch)

In general, the various AD technologies can be grouped into the following three process types:

- Wet/Low-Solids Continuously Mixed (LS-C); (TS <15-20 percent)
- Dry/High-Solids Batch/Discontinuous (AD-D); (TS >30 percent)
- Dry/High-Solids Continuous (Plug) Flow (AD-C); (TS >20 percent)

### Biogas projections

To assess the biogas production potential for the available organic feedstocks for the City of Davis, the team selected a high-solids AD process. The advantages of a high-solids system include the capability to process:

- A wider range of organic feedstocks,
- Green waste and certain types of agricultural waste, and
- Compostable bags potentially used for collecting residential and commercial organics.

The high-solids (HS) anaerobic digestion process can either be performed in a discontinuous/batch-type flow configuration (AD-D) or in a continuous/plug-flow type design (AD-C). The photographs in **Figure 5.1** show examples of AD-D and AD-C type installations.

**Figure 5.1** Examples of Anaerobic Digestion Processes: BEKON AD-D Process (left) and Hitachi Zosen Inova AD-C Process (right)



Depending upon the flow configuration and resulting digester design, pre-treatment of the organic feedstocks prior to digestion may or may not be required. A mechanical removal step for physical contaminations downstream of the digestion process (e.g., screening the digestate) is typically required to achieve a high-quality compost product.

Adding AD capacity to the City of Davis waste water treatment plant's (WWTP) low-solids digester capacity for primary sludge (PS) and thickened waste activated sludge (TWAS) could provide more flexibility in biogas utilization options.



### *Digestion of Organic Waste in AD Processes*

Two cases were selected for projecting the biogas potential from AD for an assumed annual throughput of 13,250 tons (at 50 tons per day \* 265 days per year) of source separated organics (SSO):

- Case A: Digestion of SSO (food waste and green waste), (AD-D)
- Case B: Digestion of SSO (food waste and green waste), (AD-C)

While the AD system runs 365 days per year, the biogas production estimate is based on the system's annual throughput of organics. For the purposes of this feasibility analysis, the system will receive 50 tons per day on 265 days (22 working days per month). Fifty (50) tons per day were used instead of the identified available feedstocks for AD from the City and UC Davis wastes (53.5 TPD) as it is within this project's margin of error and most systems are designed in round numbers (i.e. 50 TPD system, 100 TPD system, 200 TPD system, etc.).

**Table 5.3** and **Table 5.4** summarize feedstock characteristics (assumed quantities and composition and specific gas yields) along with related biogas projections for both cases. Based on the feedstock characteristics for the City of Davis and UC Davis, 98 percent (by weight) is comprised of green waste and two percent (by weight) of pre- and post-consumer food waste.

As illustrated in the two tables, the biogas production from the 13,250 tons/yr of SSO input is 50.2 cfm for the AD-C process compared with 33.2 cfm for the AD-D process. A slightly higher methane content of 55.3 percent in the biogas from the AD-C process can be expected compared with 55 percent for the AD-D process.

As the food waste co-collection program is maturing over time, it is reasonable to expect an increase in the amount of collected food scraps in the organics bin. **Figure 5.2** shows an example where the collected food waste of currently 2 percent of the total amount is increased to 5 percent and then to 10 percent, along with the correlating biogas production. (For this example, it is assumed that the amount of collected green waste remains the same; it does not account for future population growth which would result in an increase in generated and collected organics.)

**Table 5.3 Case A – AD-D Process; Organic Waste Quantity and Composition**

PARAMETER	FOOD WASTE (PRE- AND POST CONSUMER)	GREEN WASTE (INCL. OTHER ORGANICS) <sup>1</sup>
Mass	265 tons/yr (240.4 MT/yr)	12,985 tons/yr (11,779.8 MT/yr)
Total Solids	28%	55%
Volatile Solids	80%	80%
Specific Biogas Yield per wet ton input	1,317.5 ft <sup>3</sup> /ton (41.1 m <sup>3</sup> /MT)	
Methane Content	55 %	
Biogas Flowrate	33.19 cfm = 17,446,504 ft <sup>3</sup> /yr (494,303 m <sup>3</sup> /yr)	

<sup>1</sup> Other organics is the combined City wood waste from C&D drop boxes and street sweeping

**Table 5.4 Case B – AD-C Process; Organic Waste Quantity and Composition**

PARAMETER	FOOD WASTE (PRE- AND POST CONSUMER)	GREEN WASTE INCL. OTHER ORGANICS <sup>1</sup>
Mass	265 tons/yr (240.4 MT/yr)	12,985 tons/yr (11,779.8 MT/yr)
Total Solids	28%	55%
Volatile Solids	80%	70%
Specific Biogas Yield per wet ton input	1,993.8 ft <sup>3</sup> /ton (62.2 m <sup>3</sup> /MT)	
Methane Content	55.3 %	
Biogas Flowrate	50.23 cfm = 26,403,222 ft <sup>3</sup> /yr (747,656 m <sup>3</sup> /yr)	

<sup>1</sup> Other organics is the combined City wood waste from C&D drop boxes and street sweeping

## Gas projections from AD-C Process with increased organics diversion

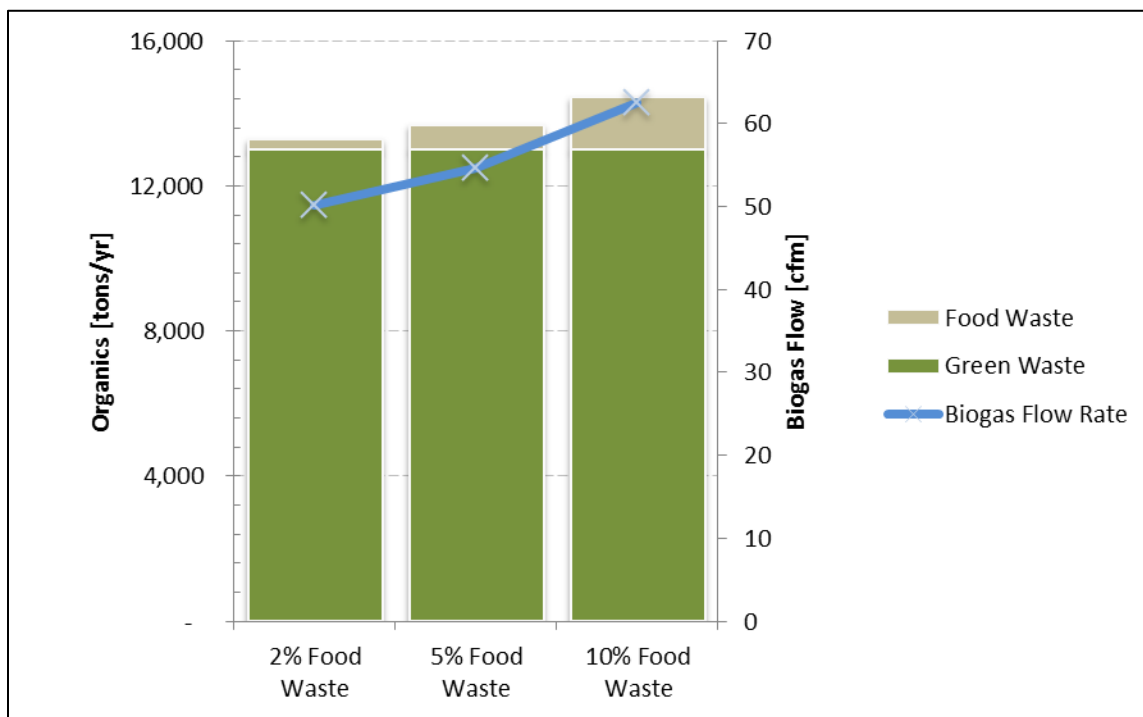
**Figure 5.2 Increase in Food Waste Collection and Resulting Biogas Production**

The biogas flow rate rises from 50.2 cfm (at 2 percent food waste) to 62.5 cfm (at 10 percent food waste). This illustrates that even a small overall increase in collected food waste can have a significant impact on the biogas production due to a higher specific gas yield for food waste compared with green waste.

*Combined biogas production – sludge digestion and municipal SSO digestion*

The average biogas flow rate from the City of Davis WWTP's sludge digesters is projected at 48 cfm under dry weather conditions. Hence, a high-solids digestion process would boost the overall biogas production on site. As shown in **Figure 5.3**, an AD-C process (fed with green waste comingled with only 2 percent food waste) could more than double the plant's projected average dry weather biogas production.

*Biogas Utilization*

As illustrated in **Figure 5.4**, a range of biogas utilization options are available to put the produced biogas to beneficial use:

- Upgrade for pipeline injection or compressed natural gas (CNG) for vehicle use,
- Generate electric power, or
- Recover heat for on and offsite use.

**Figure 5.3 Biogas Production Potential Combining the Biogas Flows from the WWTP with the AD-C Process**

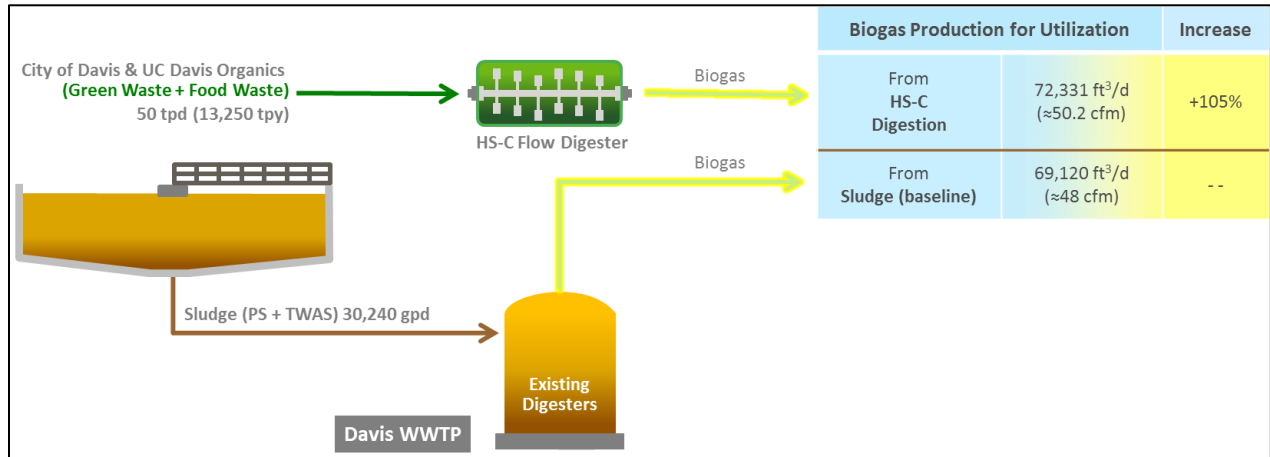

**Figure 5.4 Biogas Utilization Options**

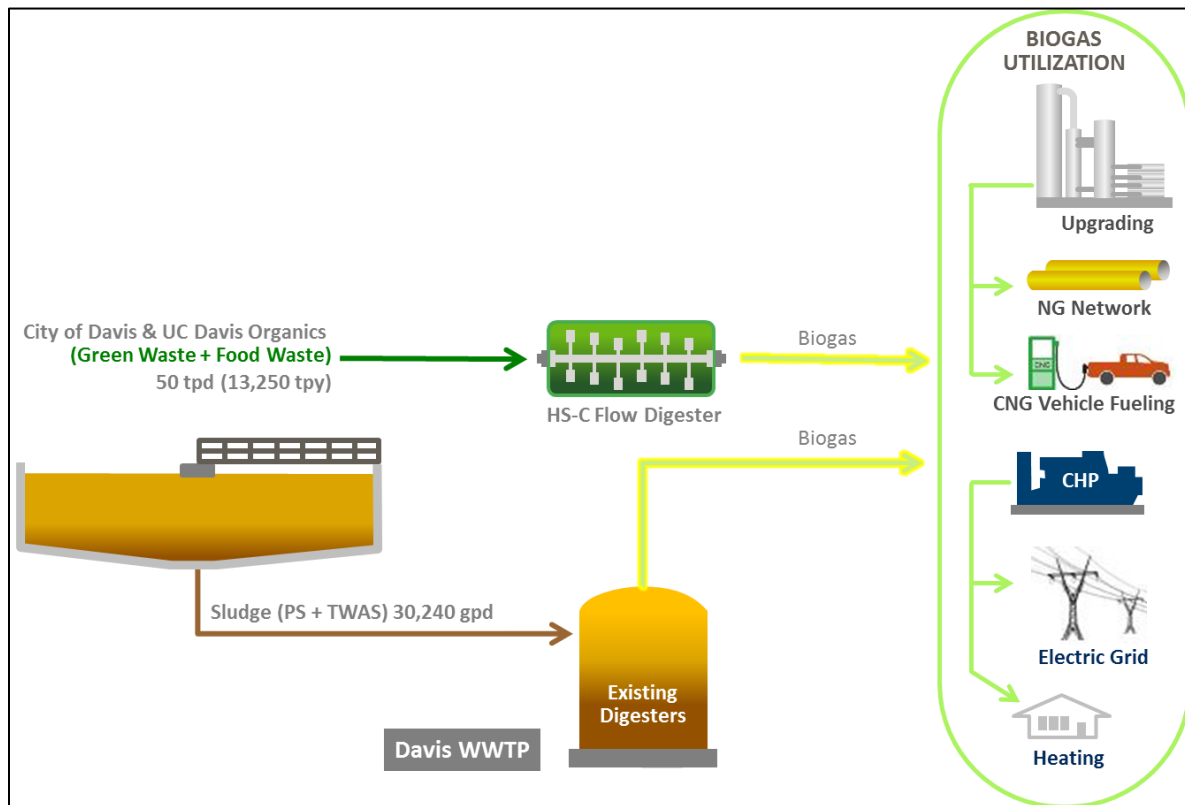

The WWTP is currently using the produced biogas to heat the WWTP on-site digesters. In the future and with the addition of the biogas from an organics AD facility, the WWTP may utilize the biogas onsite to generate electricity for the WWTP's power consumption, or to generate CNG vehicle fuel.

**Table 5.5** summarizes the biogas production and electric power output for the two digestion processes for the utilization of biogas in reciprocating internal combustion engines (RICE) for electric power (and heat generation) as one of the possible options.

**Table 5.5 Electric Power Generation Potential from Biogas Production – WWTP Sludge Digestion and Organics AD-C Digestion**

PARAMETER	WWTP SLUDGE DIGESTION	ORGANICS HS-C DIGESTION
Biogas Production	69,120 ft <sup>3</sup> /d (≈48 cfm)	72,331 ft <sup>3</sup> /d (≈50.2 cfm)
Methane Content	60%	55.3%
Energy Content <sup>1</sup>	41.47 MMBTU/d = 1.73 MMBTU/hr	39.99 MMBTU/d = 1.67 MMBTU/hr
RICE Combined heat and Power Electric Efficiency	40%	
RICE CHP Power Rating	195 kWel	188 kWel

<sup>1</sup> Assumed Methane Energy Content of 1,000 BTU/ft<sup>3</sup>

#### *Cost Comparison for Biogas Utilization Options*

In September 2016, the U.S. Environmental Protection Agency (EPA) published a report titled “Evaluating the Air Quality, Climate & Economic Impacts of Biogas Management Technologies”. Led by the University of California Biomass Collaborative, the report presents the efficiency, cost of energy, and criteria pollutant and greenhouse gas emissions (GHG) associated with seven California-based biogas management technologies:

- 1) Combustion in a RICE,
- 2) Combustion in a gas turbine,
- 3) Combustion in a microturbine,
- 4) Conversion in a fuel cell,
- 5) Processing for injection into a natural gas pipeline,

- 6) Processing to create renewable compressed natural gas (R-CNG) for vehicle fueling, and
- 7) Flaring.

Among other characteristics evaluated and compared in this report, levelized cost of energy (LCOE) was expressed as: dollar per kilowatt hour (\$/kWh) or dollar per million British Thermal Units (\$/MMBTU).

### *Summary Cost Results*

For the seven management technologies, the costs required to process biogas are illustrated in **Figure 5.5**. The cost ranges for them are as follows:

- 1) Combustion in a RICE: cost ranging from \$4.40 – \$5.35/MMBTU,
- 2) Combustion in a gas turbine: cost ranging from \$3.25 – \$4.20/MMBTU,
- 3) Combustion in a microturbine: costs ranging from \$4.30 – \$6.85/MMBTU,
- 4) Conversion in a fuel cell: costs ranging from \$10.40 – \$18.40/MMBTU,
- 5) Processing for injection into a natural gas pipeline: cost ranging from \$7 – \$25/MMBTU,
- 6) Processing to create renewable compressed natural gas (R-CNG) for vehicle fueling: \$3.40 – 12.80/MMBTU, and
- 7) Flaring: lowest cost option at less than \$1/MMBTU.

As depicted in **Figure 5.5**, all of the investigated processes show economies of scale; this is most strongly pronounced for microturbines, fuel cells and upgrading systems for R-CNG and pipeline injection, due to a combination of a couple of factors: lower per-unit capital and operating costs, and higher efficiencies at a larger scale. For locations where biogas is already available (e.g., landfills or WWTPs), management of biogas using microturbines, reciprocating engines, and gas turbines would compete with industrial and commercial electricity prices in CA.

**Figure 5.6** shows the levelized cost of electricity (LCOE) for electricity producing systems. This includes the electric power generation system discussed for the City of Davis summarized in **Table 5.5**.

**Figure 5.5 Biogas Processing Cost** (Source: BioCycle Journal, October 2016)

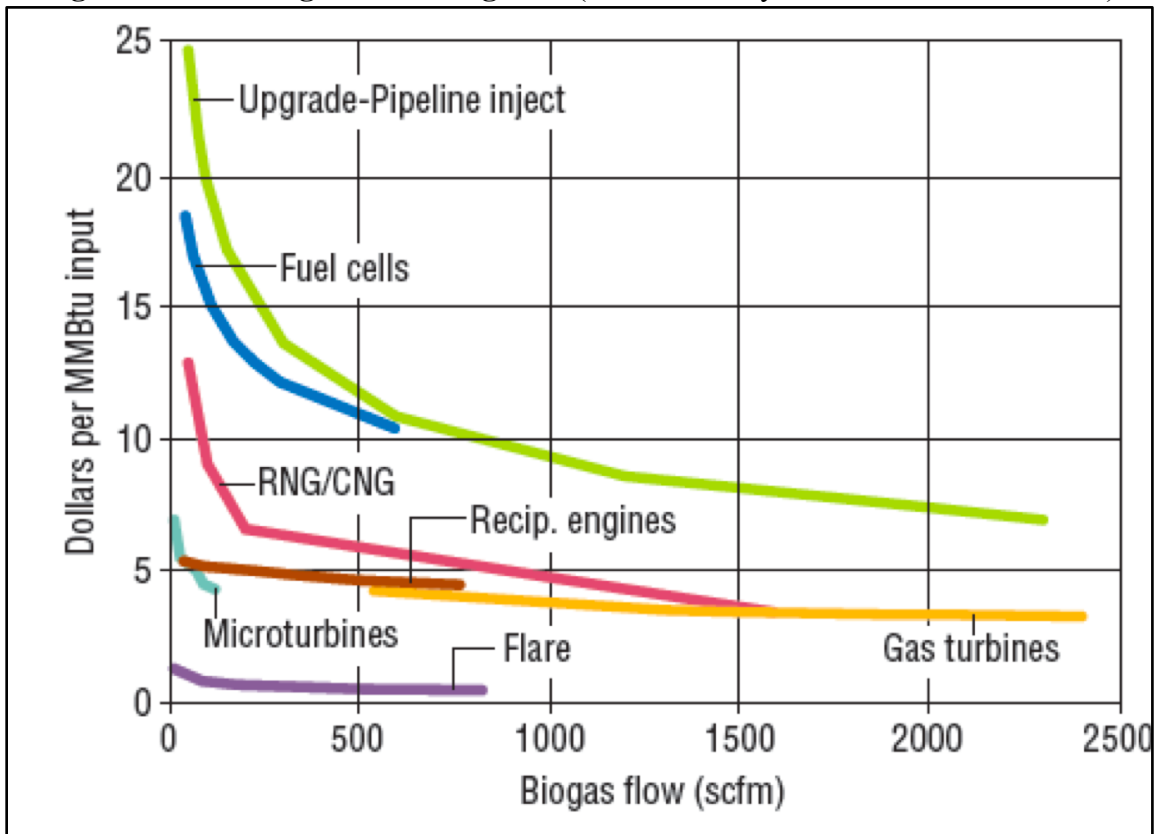

**Figure 5.6 Levelized Cost of Energy Comparison** (Source: BioCycle Journal, October 2016)

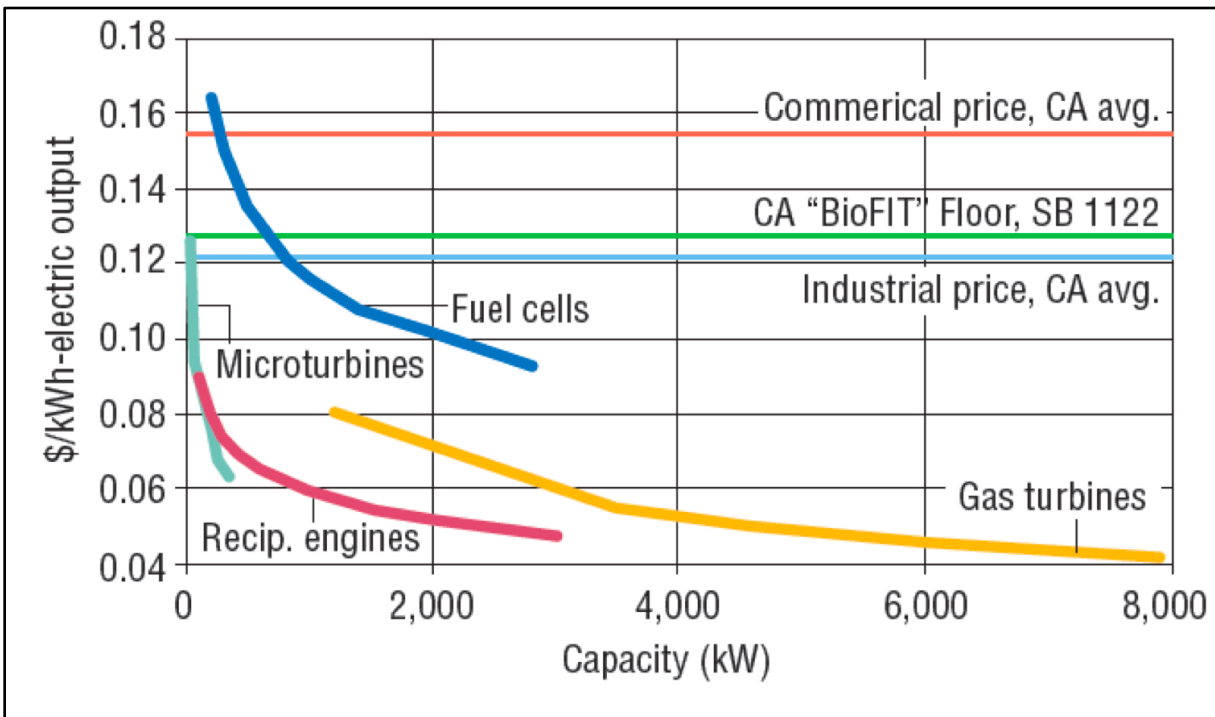

The cost ranges for the four applicable power producing systems are as follows:

- 1) Combustion in a RICE: cost ranging from \$0.09/kW for 100 kW capacity to \$0.05/kW for 3 MW capacity ,
- 2) Combustion in a gas turbine: cost ranging from \$0.08/kW for 1,2 MW capacity to \$0.04/kW for 7.9 MW capacity,
- 3) Combustion in a microturbine: costs ranging from \$0.13/kW for 30 kW capacity to \$0.06/kW for 333 kW capacity,
- 4) Conversion in a fuel cell: costs ranging from \$0.16 per kWh at a smaller capacity (200kW) to around \$0.09/kWh at 3 MW capacity.

The biogas market continues to grow in the State of California. Renewable Natural Gas (RNG) derived from organic sources like food scraps is the next frontier as the State seeks to maximize and optimize renewable sources of energy.

CNG produced from the digestion of organic waste is one of the lowest carbon intensity fuel sources available as assessed by the California Air Resources Board (CARB). Over the lifecycle of CNG fuel, it will cut GHG emissions by 80% or more compared to diesel. According to CARB, CNG is considered net-carbon-negative when produced from food waste. The use of CNG also and drastically cuts health-damaging air pollutants like particulates and NOx.

### *Potential End Users*

The biogas generated can be used as fuel for electricity generation in on-site or adjacent furnaces, boilers or other fuel needs. In addition to electricity generation the gas can also be upgraded for use in vehicles or distribution through natural gas pipelines. If absolutely necessary it can also be flared. The electricity or biogas can be used to power onsite operations, or sold to local entities or energy utilities.

When choosing biogas use options, facilities must examine each option's potential effects on economic performance, on-site labor needs, the skillsets needed to maintain and repair the equipment, and the potential need to hire a third-party operator.

### **Compressed Natural Gas**

- Pipeline: PG&E and the California Public Utilities Commission (PUC) have historically avoided approving pipeline injection of food waste derived RNG. However, there have been recent developments on this issue and the PUC is set to be adopting achievable standards in the near term. This will greatly increase the viability of pipeline injection projects in Northern California.



- **Fueling Stations:** If there is a nearby fleet of CNG vehicles that can use the CNG produced by the digestion project, constructing a fueling station is the preferable method of utilizing the biogas in the region. The California Energy Commission has awarded more than \$37 million in grants for the development and deployment of heavy duty natural gas trucks and installation and upgrades to a wide assortment of fueling stations. These programs will only continue to grow as RNG standards increase over time to meet GHG reduction goals.

### 5.3.3 Cost of Disposal and/or Recycling Byproducts

Some byproducts from organics management processes are not currently marketable in the state of California. One of the main hurdles to an economically viable organics management facility is the ability to manage and/or dispose of the manufacturing byproducts in an economical way. While compost, mulch, CNG, and electrical generation are all revenue generating byproducts of organics management options; leachate, supernatant, and digestate are byproducts which require management that results in an expense to the organics management operation.

#### **Leachate**

Leachate is an unavoidable byproduct of the composting process. Recent requirements from the State Water Resources Control Board require that leachate be managed at compost facilities through a combination of collection and conveyance systems to stormwater ponds that collect the leachate as a part of the facility's ground and stormwater management systems. This stormwater/leachate combination can be used to moisten the compost piles, while also providing a catalyst to the composting process through increased biological activity since this liquid is considered nutrient rich.

If leachate cannot be managed through a dedicated stormwater and leachate management system as described above, the leachate would have to be hauled off for treatment to the City's wastewater treatment plant (WWTP), or potentially hauled off to the Yolo County Central Landfill for injection into its anaerobic composting cells.

The cost for industrial wastewater disposal at the City WWTP is \$3.94 per account plus \$6.74 per 100 cubic feet. The most recent anticipated tip fee for YCCL's organics processing facility is \$63 per ton as received.

#### **Supernatant**

Supernatant is a byproduct of the Anaerobic Digestion process and can be described as the liquid that remains after digestion. This liquid is a result of water pumped in during the digestion process as well as water formed during the digestion process. Supernatant typically has high levels of

biological oxygen demand, ammonia, and solids. Most AD facilities currently market this to agricultural communities, either for profit or at a cost.

The most common way of managing supernatant is by introducing it back to the headworks of a WWTP. Although the supernatant is relatively small in volume, it contains dissolved and suspended organic and inorganic materials. These materials add suspended solids, nutrients (nitrogen and phosphorus), and organic compounds to the influent. Operational problems can occur as a result of introducing supernatant into the headworks of a WWTP. Potential operational issues include: increased chlorine demand, odor problems, sludge bulking, and undesired impact of high concentrations of nitrogen and phosphorus. Several operational problems are associated with the presence of high concentrations of nitrogen and phosphorus. These problems include possible permit violations, nitrification, denitrification, and excess growth of algae in secondary clarifiers. These concerns from WWTP operators could result in either the WWTP not accepting the supernatant or requiring excessively high fees for disposal at the headworks of the plant.

## **Digestate**

Digestate is the solids byproduct of the Anaerobic Digestion process. It is comprised of the fraction of the feedstock introduced to the digesters that the microbes cannot use and the mineralized remains of the dead bacteria used in the digesters. Digestate can come in three forms: fibrous, or acidogenic digestate; liquor, or methanogenic digestate; or a sludge-based combination of the two fractions. In two-stage systems the different forms of digestate come from different digestion tanks. In single stage digestion systems the two fractions will be combined and, if desired, separated by further processing.

Acidogenic digestate is a stable organic material comprised largely of lignin and cellulose, as well as a variety of mineral components. This material is similar to compost, but with a greater lignin content. Methanogenic digestate is rich in nutrients and can be used as a fertilizer based on the levels of potentially toxic elements (PTE) in the initial feedstock. Most non-industrial waste streams have low PTE levels. PTEs are typically heavy metals such as Cd, Cr, Cu, Ni, Pb, and Zn. For example, digestate produced from the source-separated organics (SSO) as an anaerobic digestion feedstock typically shows low concentrations of these PTEs whereas digestate generated from organics extraction from mixed MSW (also called organic fraction of MSW) may show higher PTEs.

Theoretically, digestate may be seen as a marketable commodity for agriculture, however, currently there is no viable or stable market for digestate in the State of California. This results in digestate being seen as a disposal expense to AD facility operators. Since one of the values of AD is diversion from landfills, it is important that AD facility operators look at options for disposal

that are considered diversion such as composting. The diversion of the incoming organic waste to the digester would count as diversion, but not the digestate from the digester itself if used as ADC.

Lab testing of all digestate will be important and necessary for ensuring the digestate will be accepted at both composting facilities for compost feedstock as well as landfills for ADC. Potential high concentrations of metals and/or ammonia may result in difficulty finding an option for digestate management. Since the material requires little to no processing and/or size reduction, tip fees will be much less than that for raw unprocessed feedstock.

For this project, it is assumed that digestate from an AD project at the WWTP would be composted there on-site. Roughly 75% of the incoming feedstock to the AD system would become digestate, then roughly two-thirds of this will become compost product. For example, using 13,250 tons per year (50 tons per day \* 265 days per year), this would equate to about 9,938 tons per year of digestate. About one-third is lost during the aerobic composting process for a total compost product of 6,625 tons of composted digestate.

## Section 6

# Alternative Project Evaluations

### 6.1 INTRODUCTION

The City of Davis collects a total of roughly 15,000 tons per year of organic material through its curbside and other collection programs, but only roughly 13,000 tons per year are organic material that may be used for this project due to excluding the inerts from the City's C&D collection. This report evaluates several organics diversion options for the City, culminating in an alternative project ranking matrix that highlights key factors necessary for an environmentally and financially successful project. This assessment identifies the most practical facility design and other specifications based on available feedstock, desired capacity, economical technology, and operator responsibilities.

The projects that have been identified for evaluation and comparison are:

1. Yolo County Central Landfill Anaerobic Composter Cells and Food Processing Facility
2. City of Davis Old Landfill Organics Processing Facility
3. City of Davis Wastewater Treatment Plant Organics Processing Facility
4. University of California Davis Composting Facility
5. Recology, Inc.

### 6.2 YOLO COUNTY CENTRAL LANDFILL

#### 6.2.1 Project Overview

##### *Existing Operations*

Yolo County Central Landfill (YCCL) is an active landfill with a maximum permitted throughput of 2,800 tons per day (TPD) broken down as follows: 1,800 TPD for disposal; 500 TPD for construction, demolition, and inerts (CDI) processing; and 500 TPD for composting. Currently the composting component operates as a chip and grind operation with no active composting. A copy of YCCL's current (July 2018) SWFP is included in **Appendix A**.

##### *Proposed Operations*

Yolo County Central Landfill (YCCL) is in the permitting and construction phases of its anaerobic composting cells, and liquid and food waste processing project. YCCL is also expanding its existing composting permitted area and design capacity. **Figure 6.1** is the YCCL Site Map which shows the anaerobic composter cells (Compost Facility #1) and the aerobic composting operation

(Compost Facility #2). **Figure 6.2** is the YCCL Storm Water Drainage Plan which identifies the liquid and food waste receiving area.

#### *Anaerobic Composter (AC) Cells (Compost Facility #1)*

This project consists of seven (7) anaerobic composter (AC) cells spread across 21 acres. Each cell is designed to hold 23,000 cubic yards, for a combined total on-site capacity of 161,000 cubic yards of material. Each cell is 150 ft. wide, 300 ft. long, and 30 ft. in height to the AC cell cover. See **Figure 6.3**, Anaerobic Composter Cell Site Plan.

Assuming the high-moisture feedstocks (ie. food waste, green waste, biosolids) have a bulk density between 350 lbs/cy to 1,500 lbs/cy, the total tonnage that could be stored in each AC cell is approximately 4,025 to 17,250 tons. Yolo County has stated Phase One of the AC cells is sized to process 52,000 tons per year. Phase Two increases to 110,000 tons per year.

YCCL plans to load each AC cells with ground food waste, green waste, and other high-moisture feedstocks in horizontal layers to a depth of 30 feet, then seal the AC cell. The waste will anaerobically digest for 22 weeks, with liquid waste from YCCL's organics processing area injected into the cell to increase biogas production which is collected through a series of pipes. When the cell cap is removed after the anaerobic treatment, the pile is then injected with air for aerobic treatment for a period of two weeks. After this combination of anaerobic and aerobic treatment (24 weeks), the digestate is excavated, screened, and either sent to Northern Recycling for composting or marketed directly as a soil amendment.

#### *Liquid and Food Waste Processing Area*

The liquid and food waste processing area has a maximum on-site capacity of 500 cubic yards of material. This capacity limit may or may not include the six (6) 7,600-gallon storage tanks used to settle solids. This area is made up of three components: 1) Liquid waste receiving, bio-separating, and dewatering area; 2) Food waste processing area; and 3) Liquid waste digester. See **Figure 6.4**, YCCL Liquid and Food Waste Processing Area.

Figure 6.1 YCCL Site Map (Source: YCCL Joint Technical Document, June 2018)



Figure 6.2 YCCL Storm Water Drainage Plan (Source: YCCL Joint Technical Document, June 2018)

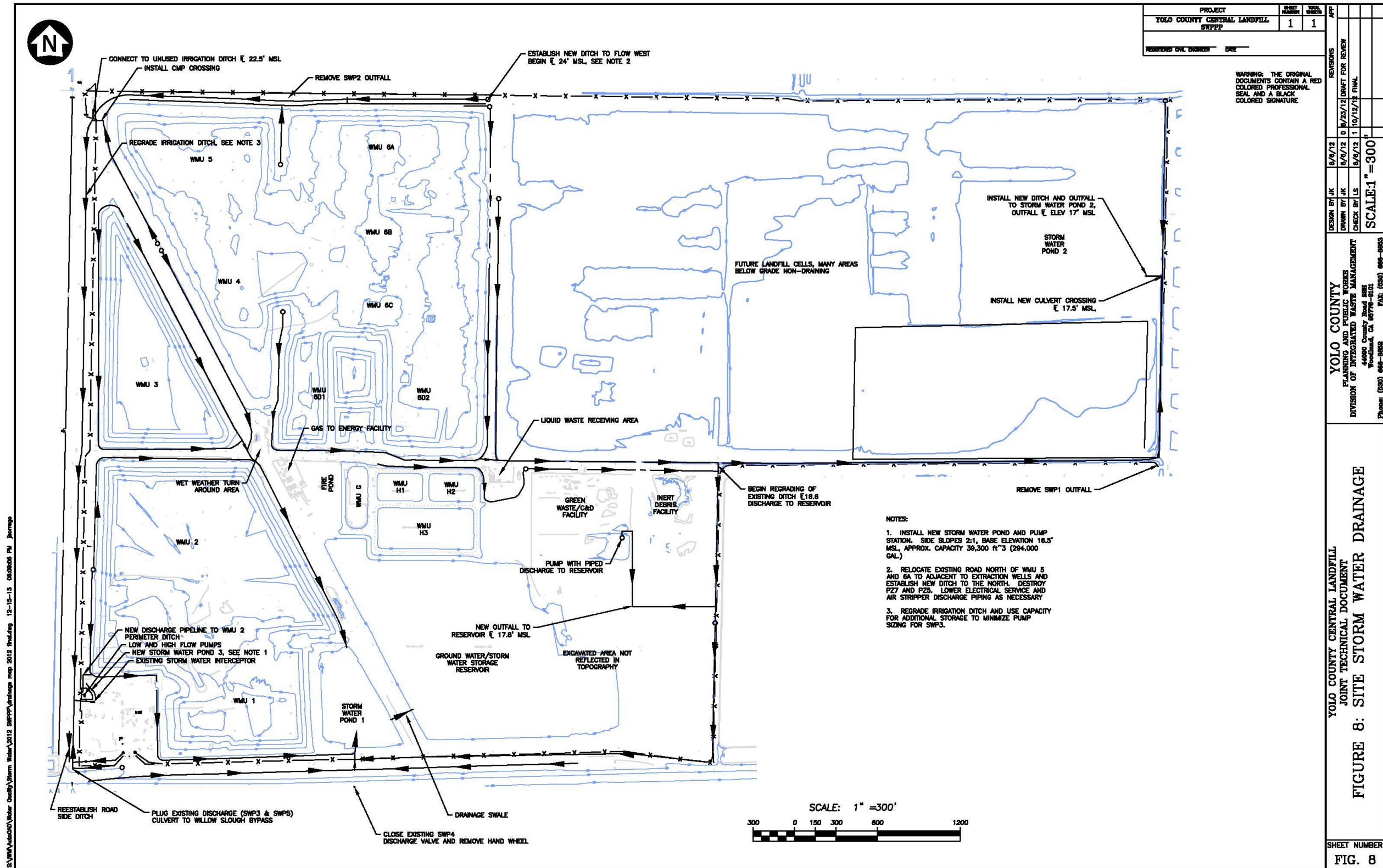

Figure 6.3 YCCL Anaerobic Composter Cell Site Plan (Source: YCCL Joint Technical Document, June 2018)

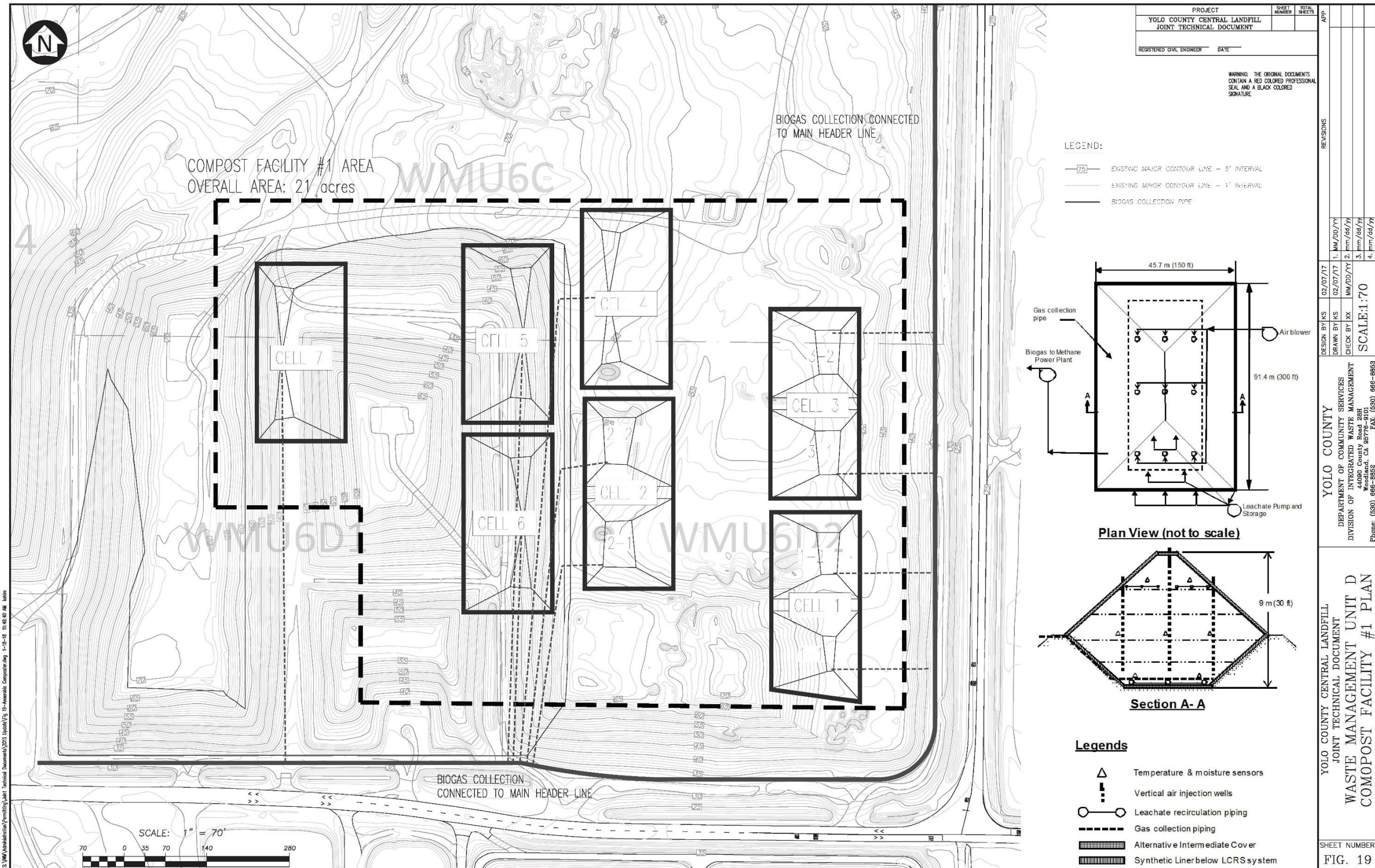
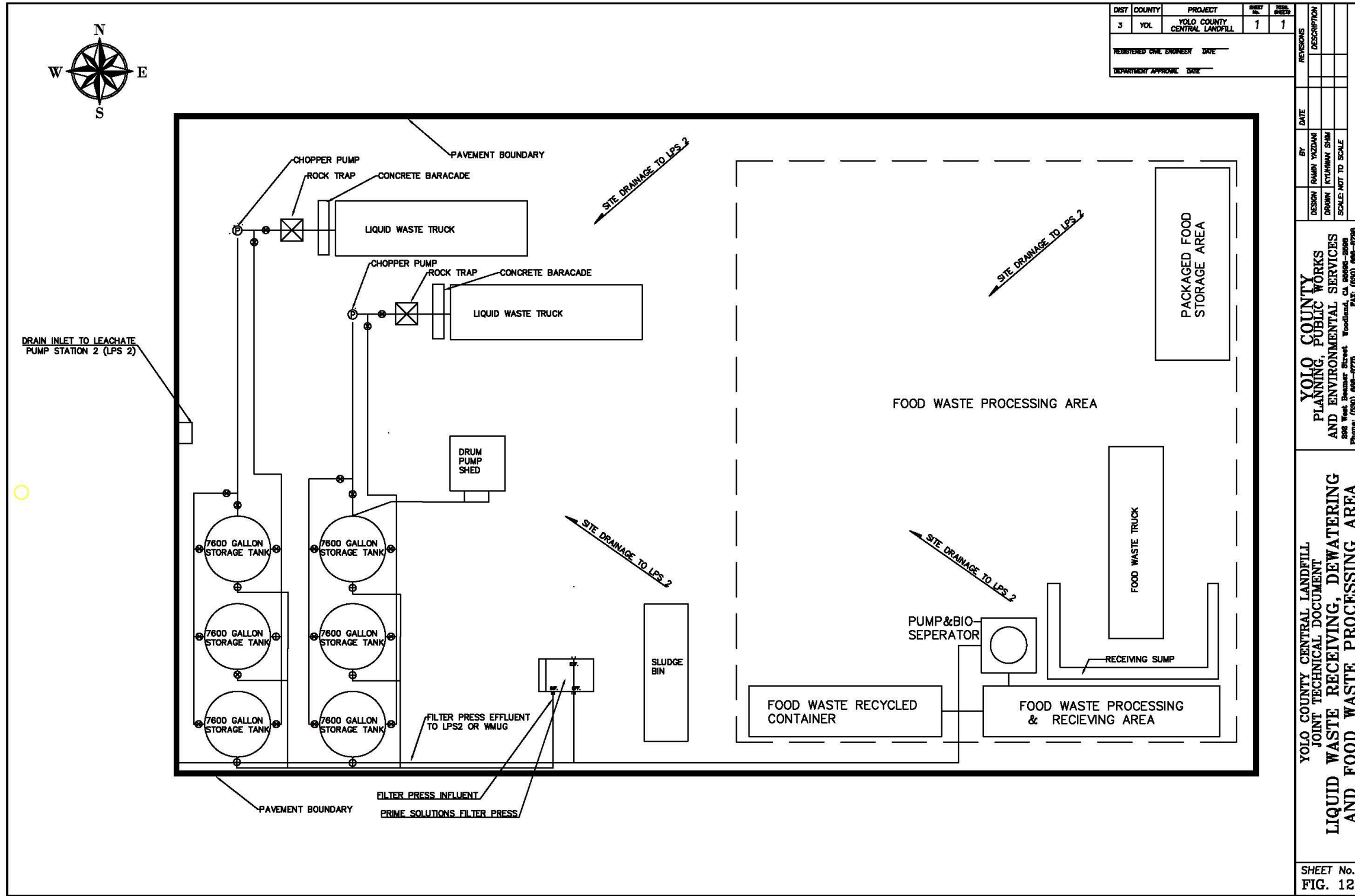



Figure 6.4 YCCL Liquid and Food Waste Processing Area (Source: YCCL Joint Technical Document, June 2018)

S:\PWL\DIGESTER (FOOD) PROJECT\Full Scale Project\Full scale digester 4\_Liquid waste receiving.dwg 2-16-16 10:00:17 AM kshim



DIST	COUNTY	PROJECT	SHEET NO.	TOTAL SHEETS
3	YOL	YOLO COUNTY CENTRAL LANDFILL	1	1

REVISIONS	DATE	BY	DESCRIPTION
		RAMAN YAZDANI	
		KYUMHAN SHIM	

YOLO COUNTY  
 PLANNING, PUBLIC WORKS  
 AND ENVIRONMENTAL SERVICES  
 898 West Research Street, Woodland, CA 95694-2698  
 Phone: (916) 688-8775 FAX: (916) 688-8798

YOLO COUNTY CENTRAL LANDFILL  
 JOINT TECHNICAL DOCUMENT  
 LIQUID WASTE RECEIVING, DEWATERING  
 AND FOOD WASTE PROCESSING AREA

SHEET No.  
 FIG. 12

### *Composting Operation (Compost Facility #2)*

YCCL was originally permitted to actively compost on five (5) acres with a maximum on-site capacity of 45,000 cubic yards. The future composting operation will expand the existing 20 acres used for the YCCL Wood and Yard Waste Facility to 40 acres with a total on-site capacity of 208,000 cubic yards. The additional 20 acres will be used for compost curing and finished product storage and be located either on top of existing landfill or on undeveloped YCCL property. Refer to **Figure 6.1** for the current location of the YCCL Wood and Yard Waste Facility which is labeled as “Green Waste / C&D Facility”.

Assuming the wood and green wastes have a bulk density of 350 lbs/cy, the total tonnage that could be stored in the compost area is approximately 36,400 tons. YCCL has stated this project will have an annual throughput capacity of 180,000 tons.

### *Feedstocks*

The lined AC cells will receive food waste, green waste, manure, wastewater treatment sludge, and other high-moisture feedstocks. In addition, the liquid waste extracted from the liquid waste processing area will be injected into the AC cells.

The composting operation component is permitted to receive municipal solid waste (MSW), green material, and construction and demolition debris (C&D).

At the time of this report, YCCL did not have any organic waste agreements in place with any of the surrounding municipalities or industrial processors, and has only received one letter of intent from the City of West Sacramento. However, the franchised hauler, Waste Management Inc., for the Cities of Winters, Woodland, and West Sacramento, Unincorporated Yolo County, and the associated food processing facilities currently hauls all organic waste to YCCL and is expected to continue this due to the hauler’s franchise agreements with each jurisdiction which includes waste flow control.

### *Technology*

Clements created a waste flow diagram to display the movements of feedstocks through the YCCL proposed projects, and is located in **Appendix B**. YCCL Senior Engineer was responsible for the design of the AC cells, which prior to this full-scale project were implemented at YCCL as a pilot research study. It appears Yolo County is also responsible for the design of the liquid waste and food waste processing area.

Northern Recycling is in the process of permitting and financing the relocation of its composting operations in Zamora to YCCL. Northern Recycling currently uses traditional windrow composting at their facility in Zamora, CA. Northern Recycling may be allowed to use windrow composting at YCCL instead of advanced methods such as aerated static pile (ASP) or use of geomembrane textile covers. The technology selection is contingent on the interpretation of the Yolo Solano Air Quality Management District (YSAQMD). As of September 2018, Northern Recycling has officially submitted a permit application to YSAQMD, but there has been no final determination on the mitigation measures required for this project. However, YSAQMD has stated that Best Available Control Technology is applicable for any new or modified source where daily pollutant emissions exceed the BACT thresholds, and there is an increase in quarterly emissions. Northern Recycling's compost operation at YCCL would most likely be considered a modified source and be required to meet YSAQMD BACT standards.

### *Operator*

Yolo County Planning and Public Works Department is listed as the sole operator of this Solid Waste Facility Permit.

Northern Recycling currently operates the Wood and Yard Waste Facility at YCCL and is in the negotiation and permitting process to operate the future composting operation located at YCCL. Northern Recycling has elected to move to YCCL to expand its composting operations. At its current location in Zamora, Northern Recycling was unable to expand due to permitting obstacles and community criticism.

B&D Geerts currently operates the CDI facility at YCCL.

### 6.2.2 Project Status

CalRecycle issued a revised Solid Waste Facility Permit (SWFP) on July 31, 2018 to include the AC cells and other organics processing operations at YCCL.

The first phase of the YCCL anaerobic composting cells is currently in the construction phase with estimated time to operations early 2019, with a goal of January 2019. At the time of the latest discussion with YCCL (December 2018), the Regional Water Board was currently reviewing YCCL's construction quality assurance (CQA) plan. The Regional Water Board has 90 days to review and approve or comment on the CQA.

The YCCL liquid and food processing building is anticipated to start-up summer 2019. YCCL awarded an equipment contractor September 2018, and expects to receive the equipment in six

months. An additional three months is necessary to install and test equipment prior to full operation.

The composting facility is on a different timeline dependent on Northern Recycling's Zamora operation relocating to YCCL. There is no expected operational date as the biggest hurdle for this move is Northern Recycling's inability to obtain proper project financing without feedstock contracts. YCCL plans to continue its Wood and Yard Waste Facility as it currently operates, sending processed wood chips and mulches to Northern Recycling's composting operation in Zamora. The organic residuals from the AC cells will also be sent to Zamora, if necessary.

YCCL will have to revise its Joint Technical Document prior to composting on-site. Although permitted through CEQA and CalRecycle for operations at YCCL, Northern Recycling is currently securing its own State Water Resources Control Board, Waste Discharge Requirements (WDR) Permit. The WDR requires Northern Recycling to construct a levee around the entire composting area proposed at YCCL, and also includes some site preparation requirements.

### 6.2.3 Financial Aspects

#### *Tipping Fee*

As of July 2018, the YCCL tipping fee for clean wood, green, and food wastes is \$54.00 per ton and their most recent estimate as of December 2018 for the AC cell project is \$63.00 per ton. This estimate is based on the assumption that the project will process 50,000 tons per year. If there is less material available for processing via the AC cells, then the per ton rate may increase.

Additionally, YCCL's tipping fee for the AC cell project is contingent on the cost to relocate Northern Recycling to YCCL. The \$63.00 per ton rate was determined late 2016, prior to the Regional Water Quality Control Board's requirement that Northern Recycling build a levee around the composting operation. The cost of construction for this levee has yet to be incorporated into Northern Recycling's rate, which in turn will most likely increase the YCCL's tipping fee for the AC cells.

Referring to *Section 4*, Feedstock Study, **Table 4.1**, DWR Hauling data, the City sent roughly 15,000 tons of organics, including C&D materials, to YCCL. Assuming YCCL will raise the tip fee from \$54.00 to \$63.00 per ton, the City will pay an increase of \$135,000 per year to take their organics to YCCL. Using the following equation, over ten (10) years, this equates to the City paying a total of about \$1.5 million more for the YCCL project compared to the current system.

Assumptions:

Organic Waste Tonnage will remain the same

Current U.S. Inflation Rate = 1.7%

$$F = A \left[ \frac{(1+i)^n}{i} \right]$$

where  $F$  = Future Cost;  $A$  = Annual Cost;  $i$  = inflation rate; and  $n$  = time

$$F = \$135,000/\text{year} \left[ \frac{(1 + 1.7\%)^{10\text{yr}} - 1}{1.7\%} \right]$$

Future Cost = \$1,458,098.97

If the City were to experience a 5% increase of Organic Waste Tonnage per year, then the increased total 10-year cost of the YCCL project to the City would be \$1.7 million compared to the status quo (i.e. \$54 per ton). Refer to **Table 6.1**, Organics Growth Tonnage and Cost with YCCL Project and **Table 6.2**, Organics Growth Tonnage and Cost at Status Quo for the cost breakdown.

**Table 6.1 Organics Growth Tonnage and Cost with YCCL Project**

Year	Previous Tonnage	Growth Rate	Growth	Total Tonnage	Est. Cost @ \$63/ton	Inflation (1.7%)	Cost w/Inflation
1				14,969	\$943,047.00		\$943,047.00
2	14,969	0.05	748	15,717	\$990,199.35	\$16,833.39	\$1,007,032.74
3	15,717	0.05	786	16,503	\$1,039,709.32	\$17,675.06	\$1,057,384.38
4	16,503	0.05	825	17,328	\$1,091,694.78	\$18,558.81	\$1,110,253.59
5	17,328	0.05	866	18,195	\$1,146,279.52	\$19,486.75	\$1,165,766.27
6	18,195	0.05	910	19,105	\$1,203,593.50	\$20,461.09	\$1,224,054.59
7	19,105	0.05	955	20,060	\$1,263,773.17	\$21,484.14	\$1,285,257.32
8	20,060	0.05	1003	21,063	\$1,326,961.83	\$22,558.35	\$1,349,520.18
9	21,063	0.05	1053	22,116	\$1,393,309.92	\$23,686.27	\$1,416,996.19
10	22,116	0.05	1106	23,222	\$1,462,975.42	\$24,870.58	\$1,487,846.00
<b>Total Organics Tonnage:</b>				<b>188,278</b>	<b>Total Cost w/Inflation:</b>		<b>\$12,047,158.27</b>

**Table 6.2 Organics Growth Tonnage and Cost at Status Quo**

Year	Previous Tonnage	Growth Rate	Growth	Total Tonnage	Est. Cost @ \$54/ton	Inflation (1.7%)	Cost w/Inflation
1				14,969	\$808,326.00		\$808,326.00
2	14,969	0.05	748	15,717	\$848,742.30	\$14,428.62	\$863,170.92
3	15,717	0.05	786	16,503	\$891,179.42	\$15,150.05	\$906,329.47
4	16,503	0.05	825	17,328	\$935,738.39	\$15,907.55	\$951,645.94
5	17,328	0.05	866	18,195	\$982,525.31	\$16,702.93	\$999,228.24
6	18,195	0.05	910	19,105	\$1,031,651.57	\$17,538.08	\$1,049,189.65
7	19,105	0.05	955	20,060	\$1,083,234.15	\$18,414.98	\$1,101,649.13
8	20,060	0.05	1003	21,063	\$1,137,395.86	\$19,335.73	\$1,156,731.59
9	21,063	0.05	1053	22,116	\$1,194,265.65	\$20,302.52	\$1,214,568.17
10	22,116	0.05	1106	23,222	\$1,253,978.93	\$21,317.64	\$1,275,296.57
<b>Total Organics Tonnage:</b>				<b>188,278</b>	<b>Total Cost w/Inflation:</b>		<b>\$10,326,135.66</b>

#### 6.2.4 Policy Issues

According to Yolo County, YCCL currently does not have organic waste flow control agreements with any of the haulers, cities, or businesses in Yolo County, however YCCL does have one letter of intent from the City of West Sacramento. When Northern Recycling relocates to YCCL, Yolo County should receive the roughly 180,000 tons of organic material per year that Northern Recycling is currently processing in Zamora. Depending on the feedstock, this material may either be fed into the AC cells or composted by Northern Recycling.

Due to the cost of the project as a whole (AC cells, liquid waste processing, and Northern Recycling composting component), YCCL is suggesting a 10-year feedstock agreement with the City of Davis. To date, no negotiations have taken place in this regard.

The greatest advantages of this project for the City is that there are no infrastructure, permitting, or project development requirements for the City. This project is remote from sensitive receptors and will have no impact on the hauler, who currently brings all organics to YCCL where it is transferred to Northern Recycling, therefore there will be no additional transportation costs or logistics alterations. The City may not receive any of the organic products (i.e. compost or biogas), but would also not be responsible for product marketing. The YCCL project supports the overall County effort in diverting waste from the landfill, and is most likely the quickest, simplest, and least expensive option for the City.

The most significant disadvantage for this option is the uncertain cost per ton (tipping fee) and the stability of that tipping fee over time. Without understanding the actual cost of this project, it is difficult to assess the total cost of the City's participation. In addition, YCCL may require a long-

term feedstock guarantee from the City, which will cause the City to be locked in to the County and its project for potentially decades into the future. This would eliminate the City's flexibility to change direction in programs or facilities as organics diversion progresses. The County's anaerobic composter cell technology, with the aeration and excavation components, is a new system developed by Yolo County. While the pilot program was deemed successful, there is a potential for under performance of this system compared to other organics handling options. In addition, the County will receive all the recognition for its environmental stewardship.

As part of the expanded scope of work, a conference call with Yolo County was conducted on September 25, 2018 to update this report and discuss possible collaboration with a City-owned and operated project. A technical memo summarizing this discussion is included in **Appendix C**.

### 6.3 CITY OF DAVIS OLD LANDFILL

The City identified their old landfill as a possible site for an organics facility. However, subsequent to the team starting work on this project, other potential uses of that site by the City came to light. As such, the site was only to be considered if the Clements team identified unique, beneficial aspects that made the Old Landfill the most ideal location for an organics facility.

The Clements team has found no such significant beneficial aspects to utilizing the Old Landfill as host for a City organics facility. However, given that conditions may change in the future, the following discussion is provided.

#### 6.3.1 Project Overview

The Clements team completed an analysis of the following:

- Land Availability
- Proximity to Sensitive Receptors
- Zoning & Permitting
- Access
- Floodplain
- Utility Availability
- Future Outlook
- Conclusion

#### *Land Availability*

The City of Davis has an inactive landfill located in unincorporated Yolo County roughly two (2) miles due north of the City center. The Old City of Davis Landfill has approximately 30 acres of

land available for a potential City organics project. The available land is outlined in red in **Figure 6.5**.

**Figure 6.5 Old City of Davis Landfill Available Land** (Source: Google Earth)



Approximately 10 acres of this land is currently being used by Blue Max Kart Club and Rate Karts! Inc. These companies' livelihood depend on the availability of this land. These local businesses currently using this land for recreation would need to be relocated, and this may have a negative impact on the businesses and their users.

#### *Proximity to Sensitive Receptors*

Less than 200 feet northwest of the property is the Davis Paintball Center. The Wildhorse Golf Club is located southeast across the street. All of these activities are outdoor public recreational areas. In addition, the nearest residential homes are roughly 0.3 miles from the property line.

The close proximity of this site to sensitive receptors could be problematic during the public permitting process for an organics facility.

#### *Zoning & Permitting*

The Old Davis Landfill is zoned "Agricultural Intensive". As described in the Yolo County Municipal Code:



“The Agricultural Intensive Zone is applied to preserve lands best suited for intensive agricultural uses typically dependent on high quality soils, water availability, and relatively flat topography.”

This zone designation may require a potential organics processing facility to go through a re-zoning process to obtain the proper zoning designation. This parcel is not subject to the Williamson Act, therefore there is no requirement to pursue the agricultural use.

#### *Access*

The Old Landfill has one access point from Pole Line Road. Collection trucks would access Pole Line Road from E Covell Blvd. (from the south) or County Road 29 (from the north). The south access runs parallel with several residential neighborhoods, a soccer field, and the Wildhorse Golf Club. Therefore, there is a potential increase of truck traffic affecting these sensitive receptors.

#### *Floodplain*

The City’s Old Landfill is located in a FEMA Flood Zone A. The area is subject to the 100-year flood event. If used for an organics composting facility, this property must hold, at a minimum, the 25-year 24-hour storm event to comply with the State Water Resources Control Board’s (SWRCB) new General Order Waste Discharge Requirements for Composting Operations. Given the close proximity of this site to sensitive receptors, the Lead Agency (City of Davis) or SWRCB may require protection for the 100-year flood event.

#### *Utility Availability*

This site has no available utilities (water and power). However, there is a nearby solar farm that may be willing to provide power to a future facility.

#### *Future Outlook*

The City has prospective plans to utilize some of the land adjacent to this area. Depending on the final use, this could result in another sensitive receptor or less available land for the project. Given this uncertainty and the other negative issues, the team has dropped this site from further considerations.

## 6.4 CITY OF DAVIS WASTEWATER TREATMENT PLANT

### 6.4.1 Project Overview

The City of Davis has a wastewater treatment plant (WWTP) located in unincorporated Yolo County near the Yolo County Central Landfill and roughly five (5) miles from the City center.

The Clements team completed an analysis of the following:

- Land Availability
- Proximity to Sensitive Receptors
- Zoning & Permitting
- Access
- Floodplain
- Utility Availability
- Future Outlook

#### *Land Availability*

The City WWTP has 170 acres of land available for a potential City organics facility. The available land is outlined in red in **Figure 6.6**.

As of the date when this portion of the report was completed (July 2017), this land was being used as an irrigation field for WWTP effluent. The WWTP recently went through an upgrade and no longer requires the irrigation field for additional treatment. One or more of the retention ponds shown to the west of the available land may be available for stormwater storage and/or treatment.

#### *Proximity to Sensitive Receptors*

The City WWTP is surrounded by agricultural land to the north, east, and south, and by the YCCL to the west. The nearest residential home is over 3,500 feet southwest from the potential project area. The 400-acre City wetlands is roughly 0.8 miles southeast from the potential project area and is home to hundreds of birds, mammals, amphibians and reptiles, and native plants.

#### *Zoning & Permitting*

The site is located in Yolo County and zoned “Public and Quasi-Public”. As described in the Yolo County Municipal Code:

“The Public and Quasi-Public zone is applied to lands that are occupied or used for public and governmental offices, places of worship, schools, libraries, and other civic uses. Other typical uses include airports, water and wastewater treatment plants, drainage basins, and sanitary landfills.”

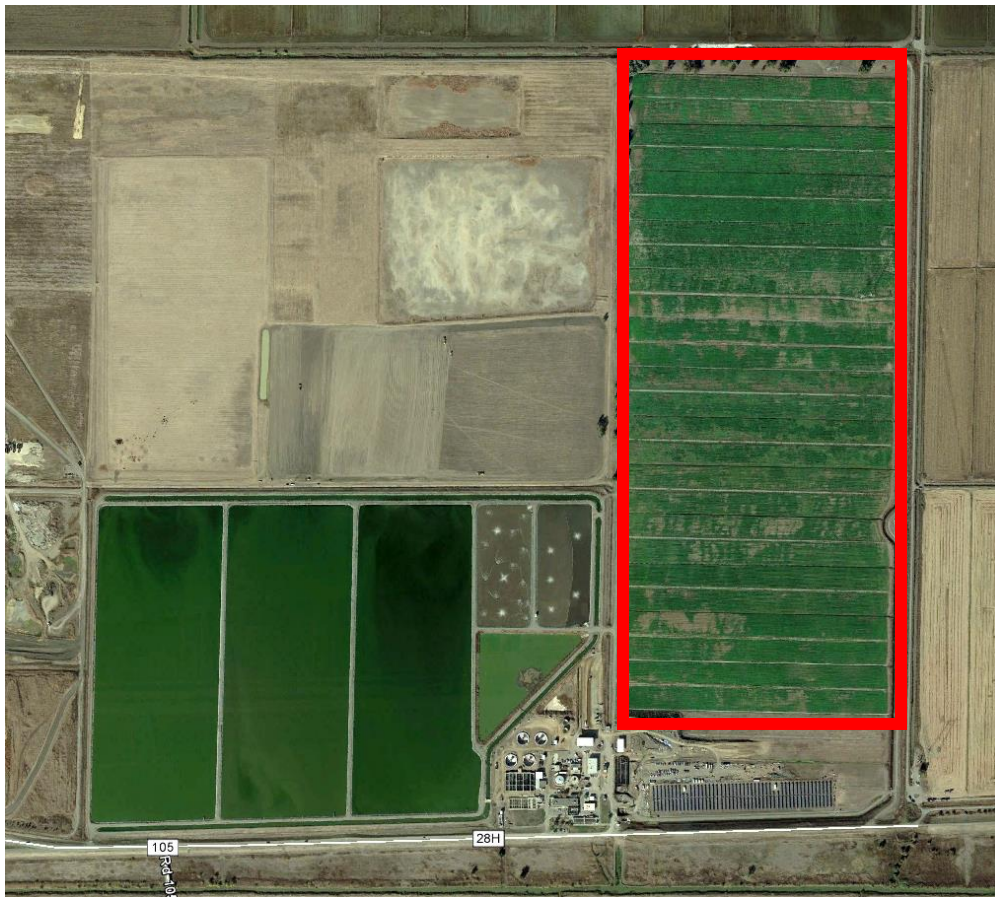
**Figure 6.6 City WWTP Available Land** (Source: Google Earth)

This zoning would be appropriate for a composting or Anaerobic Digestion (AD) project, particularly if there are synergies with the WWTP.

#### *Access*

The City WWTP is located adjacent to YCCL. Davis Waste Removal (DWR)/Recology Davis collection vehicles deliver the City's organics to YCCL for pre-processing (e.g. chip/grind), and/or transfer to Northern Recycling in Zamora. As of December 2018, the organics are now transferred from YCCL to Napa Recycling. The financial, environmental, and operational impact to divert the City's organics to the City WWTP instead of YCCL is insignificant, and instead would result in a decrease of overall transportation emissions due to the eliminated transfer to an off-site composting operation. The WWTP has one access point off County Road 28H.

#### *Floodplain*

The City WWTP is located in a FEMA Flood Zone A. The area is subject to the 100-year flood event. The City WWTP currently has a National Pollutant Discharge Elimination System (NPDES)

May 2019

permit to discharge stormwater to the Davis Wetlands. There is an opportunity for a future organics facility to be incorporated into the WWTP's NPDES permit, but most likely it will be easier to permit the organics facility separately through the General Industrial Stormwater Permit and/or the General Order Waste Discharge Requirements (WDR) for Composting Operations. At a minimum, the site would need to hold the 25-year, 24-hour storm per the SWRCB WDR. This may be provided by earthen berms, or a lined detention pond. The lead agency may require the facility to provide capacity for the 100-year storm event.

### *Utility Availability*

Due to the close proximity of the City WWTP, this land has access to power from the Pacific Gas and Electric Corporation and from the adjacent WWTP solar farm. The solar farm currently provides 40% of the power requirements for the City WWTP.

The City WWTP upgrade provides approximately 1.5 to 2 million gallon per day (MGD) of reclaimed water available for use in the summer, and 0.5 MGD of reclaimed water available for use in the winter. This could be a good source of water for an AD and/or composting project.

### *Future Outlook*

The WWTP has no current plans to utilize the area identified in this assessment, and has designated that 170 acres are available for a project.

## 6.4.2 Technical Aspects

### *Conceptual Site Plan*

**Figure 6.7** shows the location of the organics facility in relation to the WWTP. **Figure 6.8** shows the conceptual site plan of an organics processing facility.

### *Organics Throughput*

For the purposes of this study, the Clements team assumes that the project will process all available organics from the City of Davis and UC Davis, approximately 48 and 48.5 tons per day, respectively. Thus, any composting technology must be able to process roughly 100 tons per day.

Since about 85% of UC Davis' available organics is made up of animal bedding and manure, this tonnage is excluded from the potential tonnage available for an anaerobic digestion (AD) system. Thus, any proposed AD system must be able to process roughly 50 tons per day. See **Table 6.1** for the breakdown of these organics.

Figure 6.7 City WWTP Organics Processing Facility Conceptual Site Plan



NOTES	
MATERIAL UNLOADING	Area footprint: ~1.5 acre
PRODUCT STORAGE & LOADING	Area footprint: ~0.5 acre
COVERED COMPOSTING	System footprint: ~1 acre
STATIC PILE COMPOSTING	System footprint: ~11 acres
ANAEROBIC DIGESTION (w/o building)	System footprint: ~0.28 acres
CNG UPGRADING UNIT & FUELING	System footprint: ~0.15 acres

REVISIONS	

City of Davis WWTP  
Organics Facility  
Concept Plan  
45400 County Road 28H  
Davis, CA 95616

  
**CLEMENTS ENVIRONMENTAL**  
15230 Burbank Bl. Ste. 103  
Sherman Oaks, CA 91411  
(818) 267-5100

DATE: 10/04/2017	SHEET 2 of 2
FILE: WWTP Conceptual Site Plan 100417	
SCALE: 1" = 200' <small>when printed 11" x 17"</small>	

Figure 6.8 City WWTP Organics Processing Facility Conceptual Site Plan II



NOTES
MATERIAL UNLOADING Area footprint: ~1.5 acre
PRODUCT STORAGE & LOADING Area footprint: ~0.5 acre
COVERED COMPOSTING System footprint: ~1 acre
STATIC PILE COMPOSTING System footprint: ~11 acres
ANAEROBIC DIGESTION (w/o building) System footprint: ~0.28 acres
CNG UPGRADING UNIT & FUELING System footprint: ~0.15 acres

REVISIONS

**City of Davis WWTP  
Organics Facility  
Concept Plan**  
45400 County Road 28H  
Davis, CA 95616

  
**CLEMENTS  
ENVIRONMENTAL**  
15230 Burbank Bl. Ste. 103  
Sherman Oaks, CA 91411  
(818) 267-5100

DATE: 10/04/2017  
FILE: WWTP Conceptual Site Plan 100417  
SCALE: 1" = 100'  
when printed 11" x 17"

**SHEET  
1 of 2**

## Technology

The Clements team has identified two potential projects at the City WWTP as follows:

- Project 1: Stand-Alone Composting Operation
- Project 2: Integrated Anaerobic Digestion (AD) and Composting

### **Project #1 – Composting**

The Clements team has identified the following potential composting technologies applicable for the City project. More detailed air emissions analysis in coordination with the Yolo Solano Air Quality Management District will be needed in order to make a decision on which technology is best suited for this application:

- 1) Static Pile Composting (12-inch compost cover)
- 2) Covered Aerated Static Pile (CASP) Composting (membrane cover)

#### ***Static Pile Composting***

The simplest composting method to process organics comprised of predominately green, food, and animal waste, is static pile composting (typically windrows) with a 6 to 12-inch finished compost cap and watering system. Compost windrows can range in length from 200 to 600 feet long, and are typically 12 feet wide and 6 to 8 feet high. The typical composting period for this technology is 90 to 120 days. **Figures 6.9** and **6.10** show photographs of an operational static pile composting facility.

**Figure 6.9 Example Static Pile Composting Facility Aerial** (Source: Google Earth)



**Figure 6.10 Example Static Pile Composting Pile Formation**  
(Source: Tierra Verde Industries)



### ***Covered Aerated Static Pile (CASP) Composting***

The advanced composting method to process these organics is a Covered Aerated Static Pile (CASP) Composting System. One example of this technology that will be used to represent a CASP is the GORE® Cover System as shown in **Figures 6.11** and **6.12**. There are other composting technologies provided by companies such as Engineered Compost Solutions (ECS) and Green Mountain Technologies. The GORE® system is used here mainly as an example of the CASP technology with which the team is very familiar, not as an endorsement.

The standard GORE® system consists of eight (8) concrete bunkers each 165 feet long, 35 feet wide, and 8 feet high and is designed to process 100 tons per day (TPD). Each bunker can hold approximately 1,300 cubic yards of material. The GORE® system operates as follows:

- Phase I active composting: 28 days (4 bunkers)
- Phase II secondary composting: 14 days (2 bunkers)
- Phase III curing: 14 days (2 bunkers)

After each phase, the material is moved by a wheeled loader to the bunkers of the next phase. During the composting, the bunkers are covered with a semipermeable membrane that traps VOC and NH<sub>3</sub> emissions within the compost piles where they are destroyed. The piles are aerated to control temperature and moisture, and channels installed in the concrete floor collect leachate and divert it to a holding tank for further processing and reuse.



**Figure 6.11 GORE® Composting Facility Aerial** (Source: Sustainable Generation)



**Figure 6.12 GORE® Composting Facility Compost Piles**



See **Table 6.3** for a general comparison of these two technologies.

**Table 6.3 Static Pile vs. CASP General Comparison**

TECHNOLOGY TYPE	LAND REQUIRED	PILE SIZE	ACTIVE PHASE	ACTIVE PHASE PILE TURNINGS	TOTAL RETENTION TIME
Static Pile	15 acres	200' x 12' x 6'	15 days	5	90 to 120 days
CASP	2 acres	165' x 35' x 8'	28 days	1	56 days

**Project #2 – AD with Composting**

The Clements team has identified two potential AD technologies:

- 1) High Solids Discontinuous / Batch-Flow Type (AD-D)
- 2) High Solids Continuous / Plug-Flow Type (AD-C)

***Anaerobic Digestion Overview***

Anaerobic digestion is the reduction of carbon-based organic materials through controlled decomposition by microbes, accompanied by the generation of liquids and gases. In anaerobic digestion, the biodegradable, organic components of the waste stream are metabolized by microorganisms in the absence of oxygen, producing a biogas (primarily methane and carbon dioxide), a solid byproduct (called "digestate", which is generally considered to be a compost), and reclaimed water. The anaerobic digesters achieve significant diversion of 60 percent to 80 percent, assuming the composted residue can be marketed.

High solids anaerobic digestion technology can operate on a wide range of feedstocks including: green waste, food waste, food processing plant wastes, and other organic waste streams. This flexibility makes it attractive for a project in Davis with its surrounding agricultural community where a variety of feedstocks are possible. There are two types of high solids AD technologies, discontinuous and continuous, as described in *Section 5.3.2*.

***High Solids – Discontinuous / Batch-Type Flow (AD-D)***

Some of the companies providing AD-D type technologies include:

- SMARTFerm
- Organic Waste Systems (OWS)
- BEKON
- Eggersmann

The team is using the SMARTFerm technology for this study due to the small size of the proposed AD facility and the team's knowledge of the technology, its performance, and cost. This is not an endorsement of this vendor over the other competitors.

The SMARTFerm offers a 50 TPD shop fabricated steel digester, requiring roughly 4,000 square feet and can be fully assembled in as little as 90 days. The system is made up of four (4) digestion bays each 12 feet in width, 12 feet in height, and 40 feet in length. After organic waste is loaded into one of four digesters, the hatch is closed and sealed as the in-floor aeration system blows air through the material for six to eight hours. The aeration helps to biologically heat the waste to a maximum of 131 degrees Fahrenheit to support thermophilic AD. Heated liquid biological inoculant is introduced to the waste to maintain this temperate and assist in biogas production. The total residence time is 21 days, with the generation of approximately 100 to 120 scfm biogas. At the end of this process, the hatch is opened and digestate is removed to be sent to a composting operation for finishing. **Figures 6.13** and **6.14** are photos of the SMARTFerm system.

**Figure 6.13 SMARTFerm System at Monterey Regional Waste Management District**  
(Source: SMARTFerm)

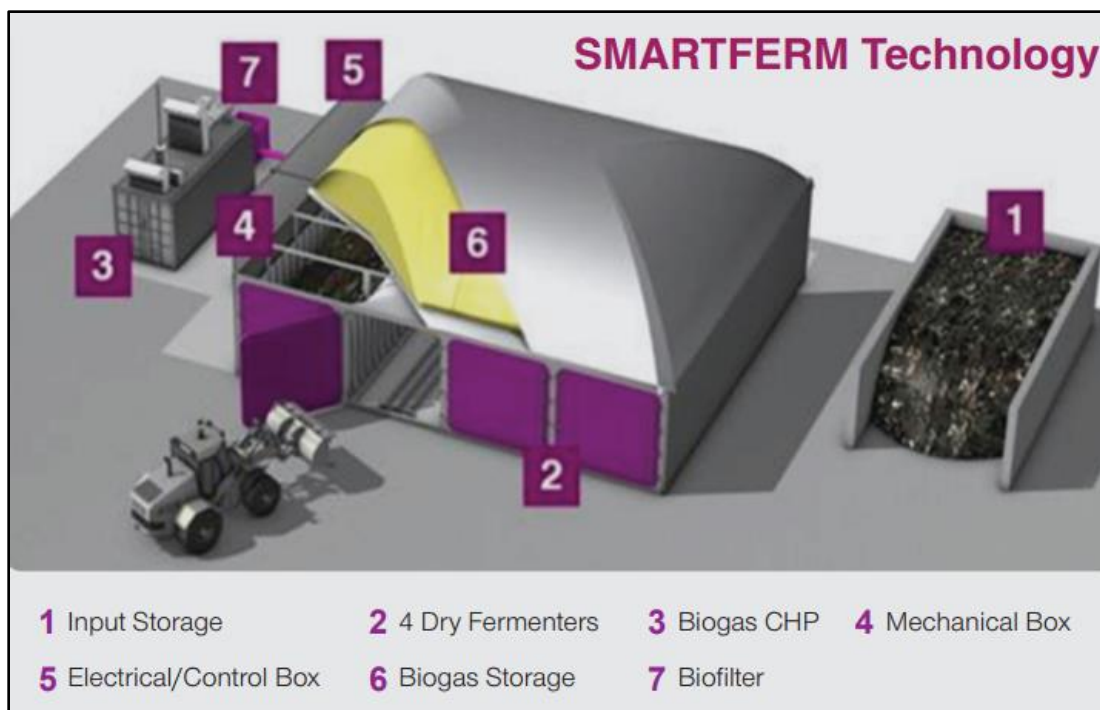

**Figure 6.14 SMARTFerm Conceptual Site Layout** (Source: SMARTFerm)***High Solids – Continuous / Plug-Type Flow (AD-C)***

Examples of AD-C type technologies include:

- Eisenmann
- Clean World
- GICON

Eisenmann’s concrete square primary digester with round post digester can process up to 60 TPD, and requires 8,000 square feet. This AD system uses a two-stage process. The first stage is a horizontal plug-flow digester that is heated, insulated, and fit with a horizontal agitator to create a homogenous mixture. The feedstock is continuously mixed to ensure the biological processes occur throughout the load to maximize biogas generation. The second stage is a heated and stirred tank with a double-membrane roof to store biogas. The typical residence time is 21 days, after which the digestate is applied directly as a soil amendment or composted for finishing. This system can process high organic loads (i.e. food waste) as well as dry materials (i.e. green waste). **Figures 6.15** and **6.16** are photos of the 60 TPD Eisenmann system. Eisenmann has shown to achieve 80% digestate and 150 to 165 scfm biogas production from feedstock inputs. Other plug-flow systems have demonstrated digestate production in the 65% to 80% range.

**Figure 6.15 Eisenmann Main Digester Schematic** (Source: Eisenmann)

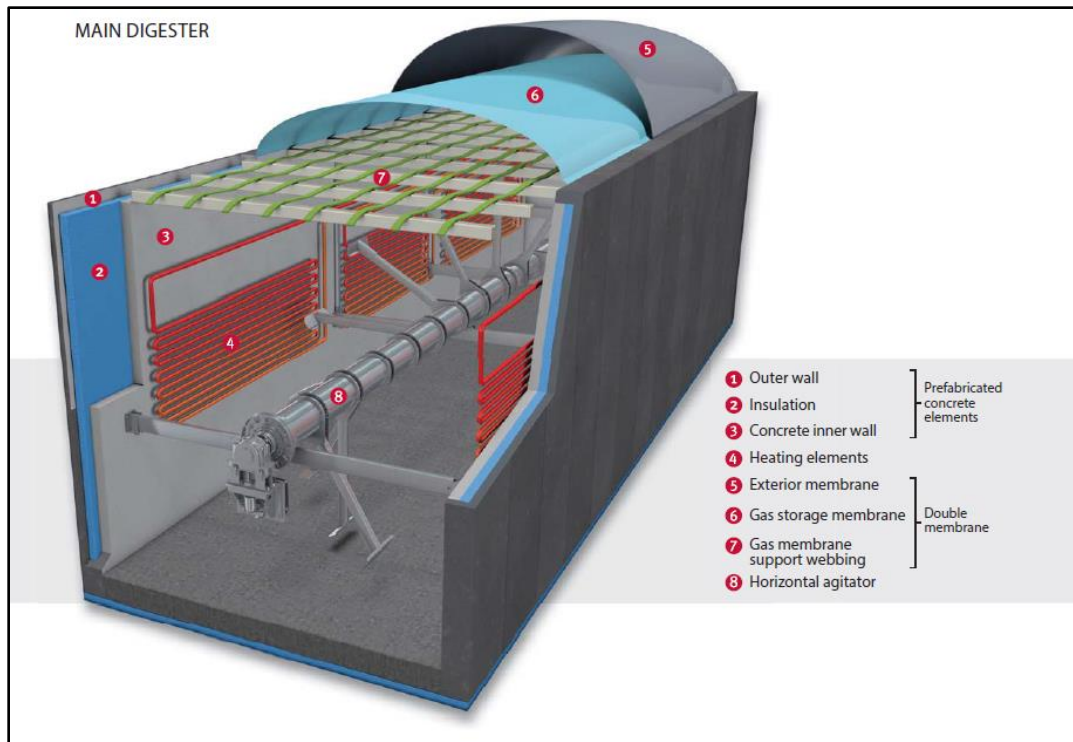

**Figure 6.16 Eisenmann Conceptual Site Layout** (Source: Eisenmann)

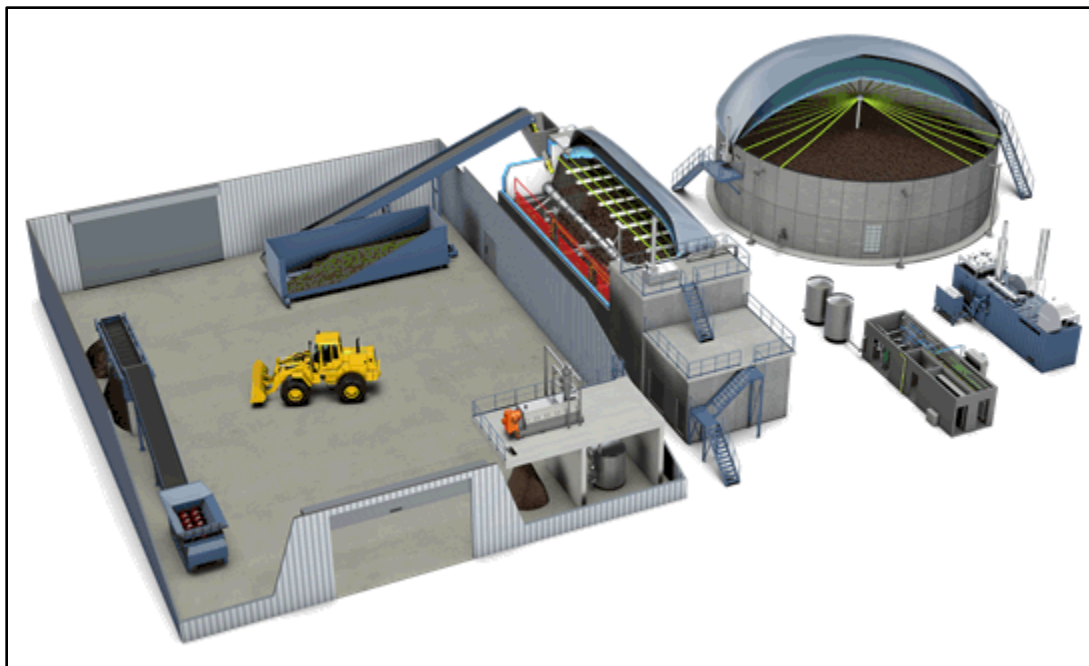

AD-D (batch) and AD-C (plug flow) have shown to result in varying digestate production, however they both typically fall within the 65% to 80% range. Therefore, the team used the average of 75% for both systems. See **Table 6.4** for a general comparison of these two technologies.

**Table 6.4. AD-D vs AD-C General Comparison**

TECHNOLOGY TYPE	TONS / DAY	SYSTEM FOOTPRINT	RETENTION TIME	DIGESTATE PRODUCTION	BIOGAS OUTPUT
AD-D	50	4,000 sf	21	75%	100 to 120 scfm
AD-C	60	8,000 sf	21	75%	150 to 165 scfm

### 6.4.3 Environmental Aspects

There are several key environmental regulations that must be considered during the design of an organics facility. For the purposes of this study, the regulations are divided by the governing body.

#### **CEQA Analysis – City of Davis**

The first step to securing permits for this City organics project is controlled by the City.

This project will require land use and CEQA approval from the lead agency, which in this case is the City of Davis. Technically, the project is located in unincorporated Yolo County, but the City has always acted as the lead agency for the City’s WWTP. Based on the project’s zoning of Public and Quasi-Public (PQP), the Lead Agency may determine only a site plan review is required. The project will most likely result in a Mitigated Negative Declaration (MND) based on the lead agency’s California Environmental Quality Act (CEQA) Initial Study. The MND will have project-specific mitigation measures to ensure the project does not have a significant effect on the environment or human health. As the lead agency, the City and/or its CEQA consultant would determine the most appropriate mitigation measures for this project.

#### **State Water Resources Control Board**

The State Water Resources Control Board (SWRCB) requires all composting facilities to comply with the General Order, Waste Discharge Requirements (WDR). Based on the tonnage throughput and feedstock types, the City’s composting operation would qualify as a Tier I facility. The requirements of a Tier I facility are summarized below:

1. Tier I feedstocks are limited to agricultural materials, green materials, paper materials, vegetative food waste, residentially co-collected or self-hauled food and green materials, and AD digestate from any allowable Tier I feedstocks;
2. The facility receives, processes, and stores less than 25,000 cubic yards of allowable compostable materials on-site at any given time;
3. The percolation rate and depth to the highest anticipated groundwater level meets the allowable WDR standards. See **Table 6.5**.
4. Areas used for receiving, processing, or storing compostable materials must be designed, constructed, and maintained to control and manage all run-on, run-off, and precipitation which falls onto or within the boundaries of these areas from a 25-year, 24-hour peak storm event, at a minimum.

These Tier I WDR requirements do not limit the City from accepting organic waste from other cities or nearby industries as long as the City accepts only allowable feedstocks, stores no more than 25,000 cubic yards of compostable material on-site at any given time, and has adequate protection from the 25-year, 24-hour storm for all operational areas.

Meat, bones, eggs, and other non-plant-based food materials are not allowed to be accepted as a Tier I facility, unless the feedstock source is considered, “residentially co-collected or self-haul food and green materials”. This is consistent with the City’s organics carts, although a final determination will need to be made by the Central Valley Regional Water Quality Control Board (CVRWQCB) to include businesses’ organics carts. The team believes this feedstock falls within the intent of the allowable Tier I feedstocks.

**Table 6.5 WDR Tier I Percolation Rate and Depth to Groundwater Standards**

SOIL PERCOLATION RATE (MPI – MINUTES PER INCH)	DEPTH TO GROUNDWATER (MINIMUM)
< 1 MPI	50 feet
1 MPI – 5 MPI	20 feet
> 5 MPI – 30 MPI	8 feet
> 30 MPI	5 feet

The National Oceanic and Atmospheric Administration’s Point Precipitation Frequency estimates the 25-year 24-hour storm event for the project site to be 4.07 inches. Based on this size storm and the project acreage shown in **Figures 6.7** and **6.8**, the project would require, at the minimum, a 2-foot earthen berm around the operations’ perimeter for stormwater protection. This is subject to approval by the CVRWQCB.

If the facility did not meet Tier I requirements, then it would need to comply with the following:

- Working surfaces must meet a hydraulic conductivity of  $1.0 \times 10^{-5}$  cm per second. Must consist of one of the following:
  - Compacted soils, with a minimum thickness of one foot;
  - Asphaltic concrete or Portland cement concrete;
- Detention ponds must meet a hydraulic conductivity of  $1.0 \times 10^{-5}$  cm per second. Must include one of the following:
  - A liner system consisting of a 40 thousandths of an inch (mil) synthetic geomembrane (or 60-mil HDPE), underlain by either one foot of compacted clay or a geosynthetic clay liner installed over a prepared base.
  - A liner system that includes Portland cement concrete, underlain by a 40-mil synthetic geomembrane (or 60-mil HDPE)
- Detention ponds must be designed and constructed with a pan lysimeter

Per the December 2018 discussion with YCCL, it was made known that the CVRWQCB required the proposed composting operation at YCCL to construct a levee around the composting operation to protect from the 100-year flood event, as the operation is located within the flood plain. This level of protection has been required for other projects if deemed necessary by the Regional Water Quality Control Board or any other governing agency (i.e., Lead Agency during CEQA review). Based on this information from YCCL, a City project at the WWTP will most likely also require protection from the 100-year flood event, especially if it is a Tier II facility. Luckily, the WWTP has retention ponds that may be available to provide this capacity.

### **Yolo Solano Air Quality Management District (YSAQMD)**

Yolo-Solano is currently designated “non-attainment” for ozone, which is created by the chemical reactions between oxides of nitrogen (NO<sub>x</sub>) and volatile organic compounds (VOCs), both of which are produced from composting. Therefore, composting operations will need to achieve Best Available Control Technology (BACT) certification. The two requirements are:

- 1) Achieved in practice
- 2) Technologically feasible (Cost-benefits ratio for cost per emission reduction)

YSAQMD has accepted aerated static piles, such as the GORE® Covered Composting System, as a BACT technology, but will assess projects with lesser air emission controls on a case-by-case basis. The San Joaquin Valley Air Pollution Control District (SJVAPCD) has BACT-certified static pile composting with 6-inches of finished compost cover plus a watering system as this method has shown to achieve 60% reduction in VOCs and 60% reduction in NH<sub>3</sub> compared to traditional windrow composting. In comparison, the GORE® Covered Composting System, a form of covered aerated static pile (CASP) composting, has consistently shown at least 80% reduction, with as high as 95% reduction, in VOCs and 75% reduction in NH<sub>3</sub>. Depending on the cost-benefit



ratio, YSAQMD may require the City to use GORE® Covered Composting System instead of static pile with 6-inch compost cap.

Due to the region's non-attainment status, emission offsets may be required to permit composting due to its generation of VOCs. YSAQMD has an offset threshold of 9,000 lbs. of VOCs per quarter. Applying the above conservative VOC reductions to SJVAPCD's standard emissions factor for organics composting, the City's composting project does not appear to require offsets if it utilizes a CASP composting system. **Table 6.6** summarizes the different VOC emissions associated with each technology as it relates to the YSAQMD offset threshold. These estimates only account for the composting portion of the project. Although material receiving, pre-processing, and storage activities will also contribute to the facility's emissions, these are much lower than the composting operation and can be reduced through a variety of best management practices such as reducing staging times.

**Table 6.6 ESTIMATED EMISSION OFFSETS REQUIRED PER COMPOST TECHNOLOGY**

TECH. TYPE <sup>1</sup>	VOC CONTROL	TPY <sup>2</sup>	VOC EF <sup>3</sup>	QUARTERLY EMISSIONS (lbs. of VOC) <sup>4</sup>	YSAQMD OFFSET THRESHOLD (lbs. of VOC)	OFFSETS REQUIRED?
Static Pile Composting	60%	25,476	2.284	14,547	9,000	Yes
CASP	80%	25,476	1.141	7,273	9,000	No

<sup>1</sup>These emission offset estimates only apply to the composting portion of the project and does not include material receiving, pre-processing, and storage activities.

<sup>2</sup>Tons per year (TPY) is based on the combined City and UC Davis organics feedstock (96.5 tons per day) at 22 working days per month.

<sup>3</sup>VOC Emissions Factor (EF) was determined by applying the VOC control to the SJVAPCD's standard organics composting EF of 5.71 lbs. of VOC per ton of feedstock.

<sup>4</sup>Quarterly emissions were determined by dividing the annual emissions by four.

Currently YSAQMD only has two composting operations within the district, both of which are existing facilities and not subject to BACT requirements. However, Recology Jepson Prairie utilizes an aerated static pile system.

### CalRecycle

This organics processing facility would need to apply for a Full Solid Waste Facility Permit, which includes a Report of Composting Site Information and Odor Impact Minimization Plan. The anaerobic digestion component would require an In-Vessel Digestion Report and a Transfer

Processing Report. Each of these documents have numerous requirements including, but not limited to, operations to meet state minimum standards, schematic drawings, hours of operation, equipment requirements, design capacity, anticipated volume of quench or process water, and final disposal method.

Upon submittal of the application, it takes at least 150 days to secure a Full Solid Waste Facility Permit. This includes 30 days to deem the application complete, 30 days to hold a public information meeting, 30 days to draft proposed permit, and 60 days for CalRecycle to approve.

#### 6.4.4 Policy Aspects

The major advantage of the City developing and operating an organics facility is the City's ability to control its own destiny. The City will be able to utilize vacant City-owned property, control the land use and CEQA permitting, and have full control over the design, operations, and cost. In addition, this project has a few possible synergies with the adjacent WWTP:

- Utilize reclaimed water generated by the WWTP for operations and dust control;
- Compost the WWTP's biosolids, in the future; and/or
- Combine the AD-generated biogas with the WWTP's biogas to produce renewable electricity to operate the WWTP

The major disadvantage of this project is the likely higher cost compared to sending the City's organic waste to YCCL, or to contracting with Recology to haul the City's organics to one of their existing processing facilities. This project will also require extensive permitting, and most likely will have a long lead time until the project is operational. While the City will enjoy profits from the generated products from this project, the City will also be in charge of marketing these products which has potential risks if the demand is low.

## 6.5 UNIVERSITY OF CALIFORNIA, DAVIS

### 6.5.1 Project Overview

The University of California, Davis (UCD) has a 50 TPD AD system at 28068 County Road 98, west of the main UCD campus. UCD is interested in developing a partnership, either through formal agreements or voluntary participation, with the City for organics processing as follows:

1. City to own and operate a composting operation on UCD property
2. City to provide its organic waste to support UCD-owned and operated composting operation on UCD property
3. UCD to provide its organic waste to a City-owned and operated organics processing facility located on City property (See *Section 6.4*)

Of these options, #1 would require a clear partnership through a lease agreement and waste agreement between the City and UCD. Options #2 and #3 can be merely participation in the other entity's organics program or through formal partnership such as a waste agreement.

The Clements team completed an analysis of following:

- Land Availability
- Proximity to Sensitive Receptors
- Zoning & Permitting
- Access
- Floodplain
- Utility Availability
- Future Outlook

#### *Land Availability*

UCD has identified roughly 13.4 acres of available land for an organics processing facility, specifically composting, to support the UCD AD facility. The available land is outlined in red in **Figure 6.17**.

#### *Proximity to Sensitive Receptors*

The available UCD land is surrounded by vacant agricultural land, the UCD AD facility, and the UCD landfill. The nearest residential homes are roughly three-quarter of a mile north.

#### *Zoning & Permitting*

This land is owned by UC Davis, and UC Davis would act as the lead agency during the CEQA process for a potential project. This allows UC Davis to require specific mitigation measures for this project.

#### *Access*

As this property is directly across the street from the UCD AD facility, there is access to the site from Lincoln Highway. This is the only access to the site and would be shared with all traffic to the UCD AD facility.

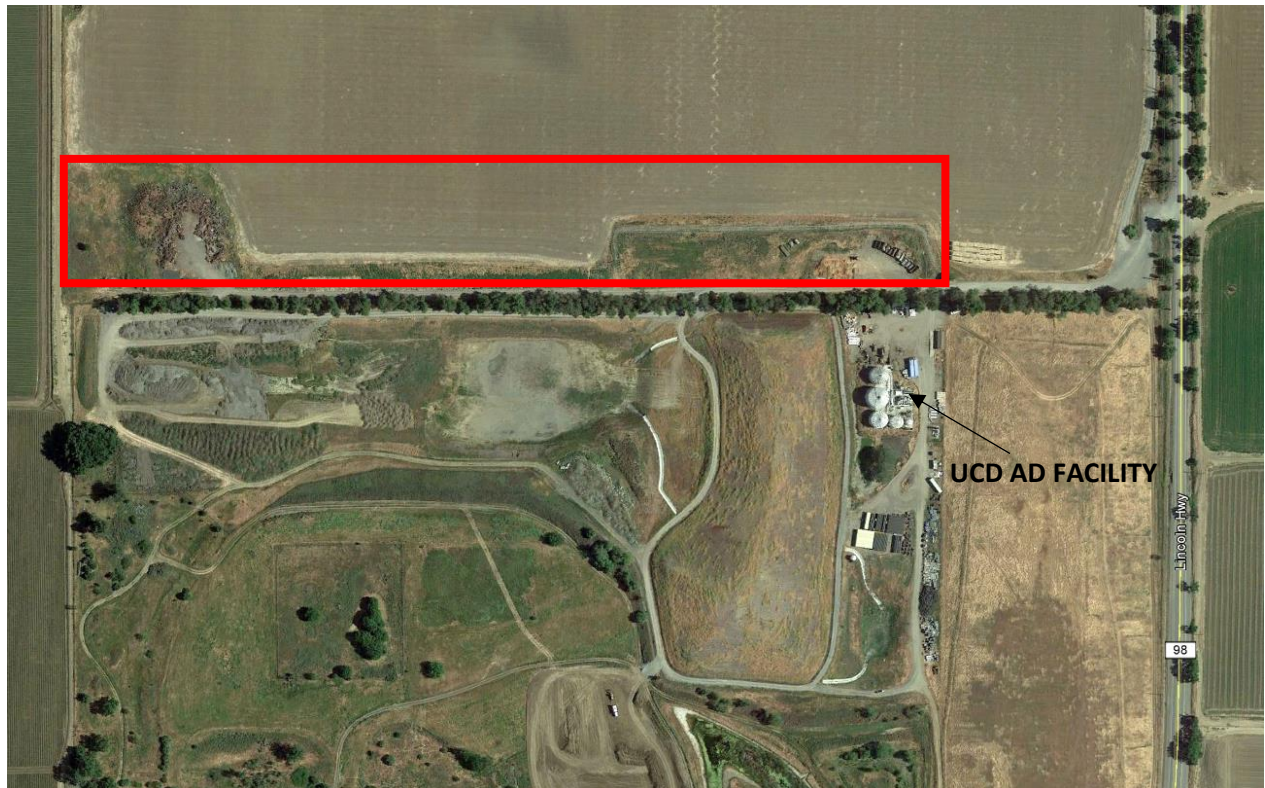
**Figure 6.17 UCD Available Land** (Source: Google Earth)

### *Floodplain*

This property is located in a FEMA Flood Zone A and is subject to the 100-year flood event. This composting project would need to comply with the NPDES General Industrial Stormwater Permit and/or the General Order Waste Discharge Requirements (WDR) for Composting Operations. At a minimum, the site would need to hold the 25-year, 24-hour storm per the SWRCB WDR. This may be provided by earthen berms, or a lined detention pond. The lead agency may require the facility to provide capacity for the 100-year storm event.

### *Utility Availability*

Due to the close proximity of the UCD AD facility, it can be assumed that this facility will have access to water and power.

### *Future Outlook*

UCD needs an economical outlet for their AD facility's digestate and process water effluent, regardless of the City's interest in developing an organics processing facility.

## 6.5.2 Technical Aspects

### *Conceptual Site Plan*

Please see **Figure 6.18** for a conceptual site plan of an organics processing facility adjacent to the UCD AD facility.

### *Organics Throughput*

For the purposes of this study, the Clements team assumes that the project will process all available organics from the City of Davis and UC Davis, approximately 48 and 48.5 tons per day, respectively. See **Table 6.1** for the breakdown of these organics.

### *Technology*

UC Davis is only interested in a City-owned and operated, or UC Davis-owned and operated composting system. The Clements team proposes the same composting technologies as recommended for the City WWTP organics project. Please see **Table 6.4** for a general comparison of these two technologies.

## 6.5.3 Environmental Aspects

The environmental regulatory requirements for an organics processing facility at UCD are identical to the requirements if the project were to be at the City's WWTP, except which public agency is the lead agency.

For a project at the City's WWTP, the City would be the lead agency during the CEQA and land use permit process. For a project at UCD, UCD would be the lead agency. This means UCD would have ultimate authority over the project's land use approval, level of CEQA required (i.e. MND or EIR), fees, and mitigation measures.

## 6.5.4 Policy Aspects

There are two options for this project, either the City leases the UCD land and operates the organics processing facility, or the City participates in a UCD owned and operated facility.

Figure 6.18 City Organics Processing Facility at UCD



NOTES	
AVAILABLE LAND:	~13.4 acres
MATERIAL UNLOADING	Area footprint: ~1.4 acres
COVERED COMPOSTING	System Footprint: ~1.0 acre
STATIC PILE COMPOSTING	System Footprint: ~9.2 acre

REVISIONS	

City of Davis UCD  
Organics Facility  
Concept Plan  
45400 County Road 28H  
Davis, CA 95616

  
CLEMENTS  
ENVIRONMENTAL  
15230 Burbank Bl. Ste. 103  
Sherman Oaks, CA 91411  
(818) 267-5100

DATE: 10/04/2017  
FILE: UCDavis Concept Plan  
SCALE: 1" = 150'  
when printed 11" x 17"

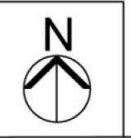

### *Option #1: City Lease and Operate*

The main advantage of a City-operated facility on UCD property is to support a regional effort with the university. Other advantages include the site's remote location to sensitive receptors and current use for chipping and grinding activities and mulch storage.

However, the City would most likely be subject to a long-term lease agreement with UCD that could involve substantial cost as well as provisions whereby UCD could take over ownership or operation of the facility. Per the latest meeting, UCD would be willing to negotiate a cost for the land, however admits to charging CleanWorld a very high lease. Additionally, the City would be responsible to support UC waste diversion efforts.

### *Option #2: UCD Own and Operate*

The main advantage for City participation in a UCD owned and operated facility is to support a regional effort between the City and University. Other advantages include no infrastructure, permitting, or product-marking burden on the City. This option would have minimal impact on the hauler, as the travel distance is similar to or less than to YCCL.

The drawbacks to this project are similar to those if the City were to participate in the YCCL organics project. The City would most likely be subject to a feedstock guarantee, severely limit the City's flexibility in choosing future options, and face an uncertain or unstable price per ton. UCD would also receive all the positive publicity for its waste diversion efforts.

## **6.6 RECOLOGY, INC.**

On August 29, 2017, Davis Waste Removal (DWR) informed the City that Recology, Inc. (Recology) offered to purchase all of the assets of DWR and continue DWR's operations in the City under the existing franchise agreement. The City had the "first right of refusal" to purchase DWR's physical assets (truck yard, MRF, etc.), but gave up that right and allowed Recology to purchase DWR as Recology Davis.

### **6.6.1 Project Overview**

Recology, Inc. (Recology) was founded in San Francisco and provides an array of services throughout California, Oregon, and Washington. Within a 70-mile radius of the City center, Recology currently owns and operates four (4) organics composting facilities and two (2) sanitary landfills. These facilities are shown in **Figure 6.19**.

**Figure 6.19 Potential Recology Organics Facilities**

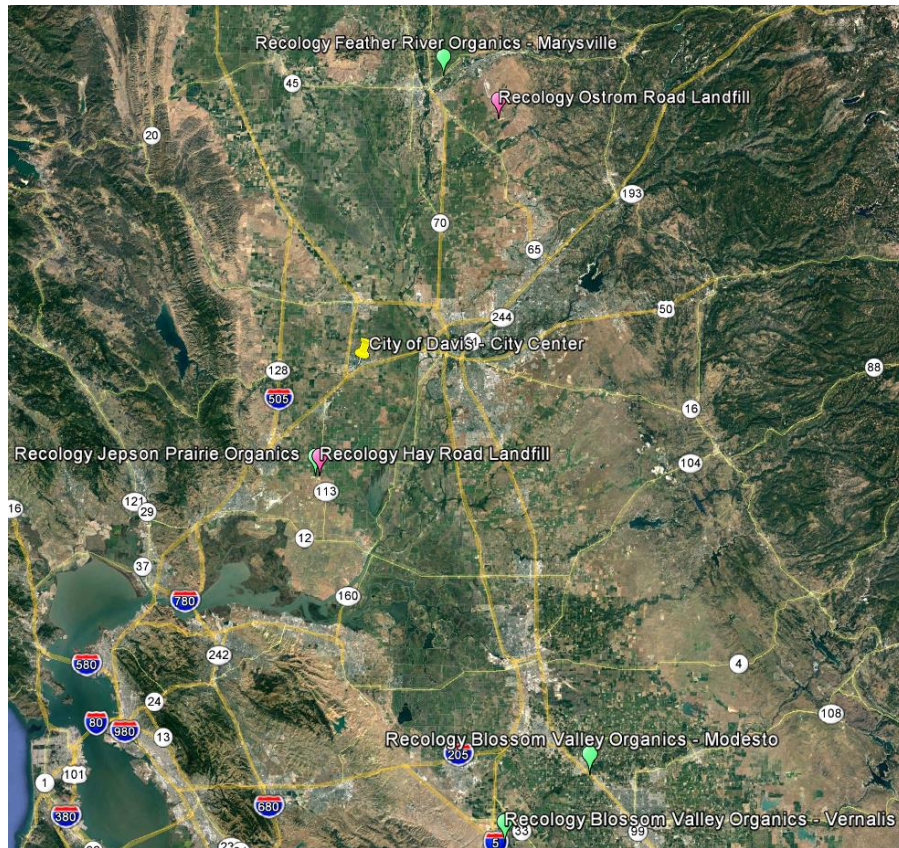

### 6.6.2 Technical Aspects

Due to the potential monopoly nature of Recology’s nearby organics processing and disposal facilities, Recology may propose to direct all of the City’s organics tonnage to their nearest facilities Jepson Prairie Organics and Hay Road Landfill. See vicinity map for the nearest Recology facilities compared to Yolo County Central Landfill in **Figure 6.20**.

#### *Jepson Prairie Organics*

Jepson Prairie Organics (JPO) has a current maximum permitted throughput of 750 tons per day for composting agricultural, food, and green wastes on 54 acres.

JPO currently uses aerated static pile composting technology. The facility is subject to the State Water Resources Control Board’s new General Order Waste Discharge Requirements (WDR) for Composting Operations and will be required to make site improvements. Recology may be able to incorporate the WDR into existing NPDES permits associated with Hay Road Landfill, therefore resulting in no additional financial burden from the WDR.

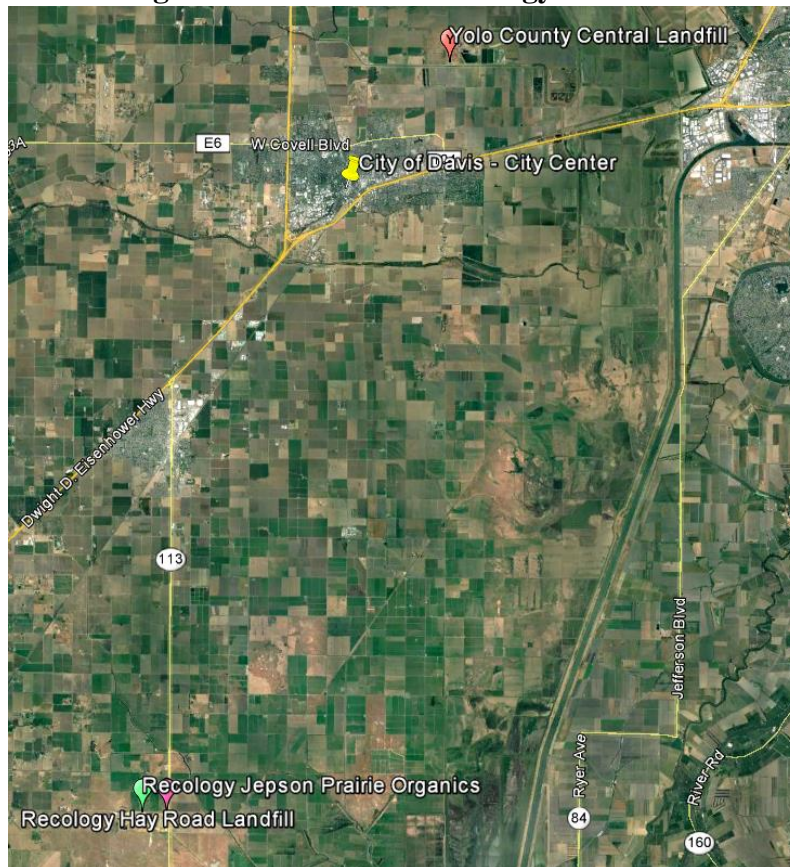

**Figure 6.20 Nearest Recology Facilities**

### *Hay Road Landfill*

Recology's Hay Road Landfill is permitted for a maximum of 2,400 tons per day for disposal or municipal solid waste, biosolids, and organics (i.e. construction/demolition, agricultural, etc.).

### *Blossom Valley Organics North*

If the City's organics needed additional processing for which JPO did not have the capacity, then Recology would most likely transfer these organics at JPO and haul them by transfer truck to Blossom Valley Organics North (BVON), Recology's largest organics processing facility in the area. BVON is located in Vernalis, CA and has a current maximum permitted capacity of 2,000 tons per day for composting food and green wastes on 123.5 acres. BVON currently uses traditional windrow composting.

### 6.6.3 Environmental Aspects

#### *Transportation Emissions*

The City has asked the team to compare the potential environmental impacts of hauling the City's organic waste to Jepson Prairie Organics or Hay Road Landfill with to the current practice of hauling to the Yolo County Central Landfill. As of July 2017, when the portion of this study was completed, DWR trucks were fueled with compressed natural gas (CNG), and it was assumed that Recology will continue using these trucks to provide City hauling services. From the City center, one roundtrip to Recology's JPO releases roughly 3.17 times more CO<sub>2</sub> equivalent (CO<sub>2</sub>E) into the atmosphere than one roundtrip to YCCL. Please see **Table 6.7** for a summary of the primary transportation impacts.

**Table 6.7 Primary Transportation Impacts**

PROJECT	FACILITY	ROUNDTRIP DISTANCE PER TRIP	VEHICLE TYPE	EMISSIONS FACTOR <sup>1</sup>	CO <sub>2</sub> E PER TRIP
STATUS QUO <sup>2</sup>	YCCL	12.0 miles	CNG collection vehicles	1.996 g CH <sub>4</sub> per mile	2.70 lbs.
Recology	JPO	38.0 miles	CNG collection vehicles	0.175 g N <sub>2</sub> O per mile	8.55 lbs.

<sup>1</sup>Source: EPA (2014) Inventory of U.S. Greenhouse Gas Emissions and Sinks: 1990-2012. All values are calculated from Tables A-104 through A-106.

<sup>2</sup>Assumes future composting will occur at YCCL, not Zamora

Currently, YCCL sends preprocessed and unprocessed green waste to Northern Recycling's composting facility in Zamora. YCCL plans to relocate the composting operation to YCCL, however there is no anticipated start date for this change to occur.

If Recology were to need additional processing capacity not available at JPO, Recology would most likely transfer the organic waste to BVON, via diesel fueled transfer trucks.

#### *Composting Emissions*

Recology JPO currently uses aerated static pile composting, which is a certified Best Available Control Technology by the San Joaquin Valley Air Pollution Control District (SJVAPCD). The Yolo-Solano Air Quality Management District (AQMD) does not have a list of technologies that are certified BACT, but require new composting operations to meet BACT-requirements. Yolo-Solano AQMD and many Air Districts rely on the more stringent Air Districts for guidance since the more stringent districts have established rules, certifications, technology review, emissions data, and etc. For this particular project, SJVAPCD has defined stringent emissions requirements,

May 2019

and adopted specific rules that relate to the composting operations. This technology has shown to reduce VOC emissions by 80% and ammonia emissions by 50% compared to traditional composting methods. BVON uses traditional windrow composting methods.

#### 6.6.5 Financial Aspects

The tipping fee at JPO and Hay Road Landfill are dependent on waste type, volume, and contamination level as well as the processing or disposal contract. Typically tipping fees at JPO are \$40 per ton for clean green, \$70 per ton for residential green and food waste, and \$90 per ton for commercial organics. The typical tip fee for MSW at Hay Road is \$40 per ton. The City may have some room to negotiate with Recology on these tip fees.

#### 6.6.6 Policy Aspects

Due to Recology's acquisition of DWR, this is most likely the quickest, simplest, and least expensive option for the City. Recology may be able to offer the City a deal if the City agrees to send its organics waste to JPO for processing and solid waste to Hay Road Landfill for disposal. This option also demands no infrastructure, permitting, or product marketing efforts from the City.

As with any project where the City is not the operator, the City will most likely be required to commit to a feedstock guarantee and, therefore, lose control of future system options. The City would be subject to the cost per ton as determined by Recology, which could change significantly and suddenly. With this option, Recology would get all the recognition for its diversion efforts.

As part of the expanded scope of work, a meeting was held with Recology Davis about their plans for organics in April 2018. The City was present for these discussions. A technical memo summarizing this meeting is included in **Appendix D**.

### 6.7 COMPARATIVE EVALUATION MATRIX

**Table 6.8** on the following page summarizes the key aspects of each of these potential projects.

**Table 6.8 City of Davis Comparative Evaluation Matrix**

PROJECT	ACRES	FEEDSTOCKS	TONS PER DAY[1]	TECHNOLOGY	PRODUCTS	ADVANTAGES	DISADVANTAGES
1) YCCL	61	City of Davis · Mixed green and foodwaste · Greenwaste (loose) · Other Organics	26 18 4	Anaerobic Composting Cells & Foodwaste Processing Area	1) Biogas to electricity 2) Compost	No infrastructure for City No permitting/project dev. for City Supports overall County effort Most likely quickest, simplest, & least expensive No impact on hauler No product marketing/value for City Remote from sensitive receptors	Feedstock guarantee may be required Loss of control of future system options Uncertain \$/ton price and stability Likely poor performance of bioreactor County gets all the recognition
2) Old City Landfill	10	N/A	N/A	N/A	N/A	City controls own destiny City owned land currently vacant (mostly) Current SWFP? No. Not even "Inactive" Current C.U.P. and CEQA? Probably Not	Cannot build on fill material Feedstock guarantee may be required City plans for other development at site No ability to use electricity on site May require utility work
3) City WWTP	170	City of Davis · Mixed green and foodwaste · Greenwaste (loose) · Other Organics  UC Davis · Postconsumer Foodwaste · Greenwaste · Digestate · Animal Bedding	26 18 4  0.5 5 2 41	1) High solids AD w/ Composting 2) Stand Alone Composting	1) Biogas w/ WWTP · CNG · Electricity · to YCCL 2) Compost	City controls own destiny City owned Land City-controlled land use and CEQA permitting Synergies with WWTP (feedstocks, products) Full city control of design, operations, cost City control of products for optimal benefit Free compost giveaway possible to residents Potential better economies of scale w/ other towns and industries No impact on hauler City gets recognition	Extensive permitting required Long lead time Likely higher cost than options 1 & 5 Product marketing risk/reward is City's
4) UC Davis	13.4	Same feedstocks as Project #3		Composting 1) City lease/op. 2) UC own/op. [2]	1) Compost	Supports a regional effort with UC <u>If City lease/op:</u> Remote from sensitive receptors Land currently used for chip/grind & storage <u>If UC own/op:</u> No infrastructure for City No permitting/project dev. for City Minimal impact on hauler No product marketing/value for City	<u>If City lease/op:</u> Cost of lease Responsible for UC waste diversion <u>If UC own/op:</u> Feedstock guarantee may be required Loss of control of future system options Uncertain \$/ton price and stability UC Davis gets all the recognition
5) Recology	10	Same feedstocks as Project #1		N/A	1) Compost	No infrastructure for City No permitting/project dev. for City Most likely quickest, simplest, & least expensive No product marketing/value for City	Feedstock guarantee may be required Loss of control of future system options Uncertain \$/ton price and stability Recology gets all the recognition

[1] Tons per day based on 265 days per year

[2] The UC own/op project option is not included in the project proformas as this option is dependent on the UC's tip fee and other project requirements all of which are unknown at the time of this study.

## Section 7

# Project Economics

### 7.1 SUMMARY

The Clements team has identified four options for the City of Davis to own and operate an organics processing facility at the City's WWTP, and two on UC Davis property. For purposes of this study, the team combined Covered Static Pile Composting, the Discontinuous/Batch Flow AD, and biogas power production as the less sophisticated and less expensive scenario (Option C); and the Covered Aerated Static Pile composting (CASP), the Continuous/Plug Flow AD, and the CNG production as the more sophisticated, higher performing, and expensive option (Option D). In this way, the range of project possibilities was covered, without having to analyze every possible combination of composting, AD, and biogas utilization technologies, which was beyond the scope of this work. See **Table 1.1** in *Section 1, Executive Summary* for a summary of the five project options broken down by location, technology, type, capital cost, operating cost, products, revenue from products, and net cost per ton of feedstock.

To calculate cost per ton, the Clements team determined equipment and labor requirements, capital, operational, and maintenance expenses, and value of the products generated. City utility and labor rates were used. For alternative projects located at the UC Davis site, the team did not include potential lease payments for use of UC Davis land. Depending on the lease payments, this could have a significant effect on these option's economics.

**Table 7.1** shows the pro forma summary. Please refer to **Appendix E** for the full pro forma.

### 7.2 PROJECT DISCUSSIONS

This section provides an overview discussion of the key economic aspects of each option.

#### 7.2.1 WWTP Located Options

**Table 7.2** displays the key financial points for a project at the City WWTP.

#### *Options A and B – Stand-Alone Composting*

Options A and B assume available organics from the City and UCD, except their respective biosolids, are sent to the composting system from which two-thirds is converted into a finished compost product. As described in the product market study, compost product sells for an average of \$20 to \$40 per ton depending on certification, quality, and volume. For the purposes of this pro forma, the Team gave the compost product the conservative value of \$20 per ton.

**Table 7.1 Pro Forma Summary**

	SITE - WWTP								SITE - UC DAVIS			
	Option A Composting		Option B Composting		Option C AD & Composting AD-D & Covered Static Pile		Option D AD & Composting AD-C & CASP		Option E Composting		Option F Composting	
	Covered Static Pile		CASP		Covered Static Pile		AD-C & CASP		Covered Static Pile		CASP	
	\$ Per Incoming ton Annual		\$ Per Incoming ton Annual		\$ Per Incoming ton Annual		\$ Per Incoming ton Annual		\$ Per Incoming ton Annual		\$ Per Incoming ton Annual	
<b>Operations Costs</b>												
Labor	\$17.05	\$434,417	\$13.78	\$351,184	\$26.86	\$684,321	\$27.46	\$699,622	\$17.05	\$434,417	\$13.78	\$351,184
Equip Maint & Ops	\$5.58	\$142,032	\$5.51	\$140,376	\$10.48	\$267,032	\$14.34	\$365,376	\$5.58	\$142,032	\$5.51	\$140,376
<b>Sub-Total</b>	<b>\$22.63</b>	<b>\$576,449</b>	<b>\$19.29</b>	<b>\$491,560</b>	<b>\$37.34</b>	<b>\$951,353</b>	<b>\$41.80</b>	<b>\$1,064,998</b>	<b>\$22.63</b>	<b>\$576,449</b>	<b>\$19.29</b>	<b>\$491,560</b>
<b>Disposal Costs <sup>1</sup></b>												
Disposal - Residual Solid Waste Recovered/Diverted w/Negative Value	\$0.00	-	\$0.00	-	\$0.00	-	\$0.00	-	\$0.00	-	\$0.00	-
<b>Sub-Total</b>	<b>\$0.00</b>	<b>\$0</b>	<b>\$0.00</b>	<b>\$0</b>	<b>\$0.00</b>	<b>\$0</b>	<b>\$0.00</b>	<b>\$0</b>	<b>\$0.00</b>	<b>\$0</b>	<b>\$0.00</b>	<b>\$0</b>
<b>General &amp; Administrative Costs <sup>2</sup></b>												
Personnel <sup>3</sup>												
Facility G&A	\$1.98	\$50,400	\$1.98	\$50,400	\$1.98	\$50,400	\$1.98	\$50,400	\$1.98	\$50,400	\$1.98	\$50,400
<b>Sub-Total</b>	<b>\$1.98</b>	<b>\$50,400</b>	<b>\$1.98</b>	<b>\$50,400</b>	<b>\$1.98</b>	<b>\$50,400</b>	<b>\$1.98</b>	<b>\$50,400</b>	<b>\$1.98</b>	<b>\$50,400</b>	<b>\$1.98</b>	<b>\$50,400</b>
<b>Debt Service &amp; Equipment Replacement</b>												
Debt Service <sup>4</sup>	\$4.97	126,531	\$20.48	521,740	\$33.04	841,836	\$65.40	1,666,073	\$4.97	126,531	\$20.48	521,740
Equipment Replacement	\$3.45	\$87,857	\$15.78	\$402,071	\$25.51	\$649,857	\$48.02	\$1,223,371	\$3.45	\$87,857	\$15.78	\$402,071
<b>Sub-Total</b>	<b>\$8.42</b>	<b>\$214,388</b>	<b>\$36.26</b>	<b>\$923,812</b>	<b>\$58.55</b>	<b>\$1,491,694</b>	<b>\$113.42</b>	<b>\$2,889,444</b>	<b>\$8.42</b>	<b>\$214,388</b>	<b>\$36.26</b>	<b>\$923,812</b>
<b>Total Costs</b>	<b>\$33.02</b>	<b>\$841,237</b>	<b>\$57.54</b>	<b>\$1,465,772</b>	<b>\$97.87</b>	<b>\$2,493,447</b>	<b>\$157.20</b>	<b>\$4,004,842</b>	<b>\$33.02</b>	<b>\$841,237</b>	<b>\$57.54</b>	<b>\$1,465,772</b>
<b>Revenue from Commodity Sales</b>	<b>\$13.33</b>	<b>\$339,682</b>	<b>\$13.33</b>	<b>\$339,682</b>	<b>\$20.21</b>	<b>\$514,932</b>	<b>\$36.04</b>	<b>\$918,049</b>	<b>\$13.33</b>	<b>\$339,682</b>	<b>\$13.33</b>	<b>\$339,682</b>
<b>Net Cost</b>	<b>\$19.69</b>	<b>\$501,555</b>	<b>\$44.20</b>	<b>\$1,126,090</b>	<b>\$77.66</b>	<b>\$1,978,515</b>	<b>\$121.16</b>	<b>\$3,086,793</b>	<b>\$19.69</b>	<b>\$501,555</b>	<b>\$44.20</b>	<b>\$1,126,090</b>
<b>Incoming Tons</b>	25,476		25,476		25,476		25,476		25,476		25,476	

Notes

1. Assumes no disposal costs.
2. General and administrative costs are expenses required to administer a business, and which are not related to the construction, production or sale of goods or services.
3. No General & Administrative staff is included in this Pro-Forma.
4. This represents principal and interest.

**Table 7.2 City WWTP Project Key Financial Points**

OPTION	CAPEX <sup>1</sup>	\$ / TON	REVENUE / UNIT	TOTAL REVENUE	# OF STAFF
A	\$982,000	\$19.69	Compost: \$20/ton	<b>\$339,682</b>	4.5
B	\$3,996,000	\$44.20	Compost: \$20/ton	<b>\$339,682</b>	3.5
C	\$6,602,000	\$77.66	Power: \$0.166/kwh	\$222,331	7.0
			Compost: \$20/ton	+\$292,601	
				<b>\$514,932</b>	
D	\$13,459,000	\$121.16	CNG: \$4.03/DGE	\$625,448	7.0
			Compost: \$20/ton	+\$292,601	
				<b>\$918,049</b>	

<sup>1</sup> Capital Expenditures

While the CAPEX for the static pile composting system (Option A) is less than half that of the covered aerated static pile (Option B), it is more labor intensive. Essentially, with the more expensive Option B composting technology, the City is paying for a much higher level of environmental control, for both air emissions and stormwater runoff.

It is important to note that the City must receive approval from the YSAQMD prior to operation of either composting system. This is particularly important for Option A because the YSAQMD has not made a determination if static pile composting (Option A) would be permitted within the District due to BACT requirements. The San Joaquin Valley APCD has certified such a system as BACT, which is a positive indication that this simpler technology may be approved in the YSAQMD.

#### *Options C and D – AD with Composting*

Options C and D assume all green waste, mixed green and food wastes, post-consumer food waste, and other City organics (street sweepings and 15% wood waste recovery from City C&D boxes) is sent directly to the AD system, and the UCD animal bedding and digestate are sent directly to the composting system. Roughly 50% of the incoming feedstock to the AD system will become digestate, which will then be mixed with the UCD feedstocks and placed into the composting system. The same composting conversion factor of two-thirds of the incoming mass becoming compost, and product market value of \$20 per ton used for Options A and B were applied.

One key addition that was necessary for the Option D AD system was a receiving building of 15,000 sf to receive and process the incoming organic material prior to feeding into the digestion system.

Both AD technologies produce biogas which can be converted into electricity or CNG fuel. For the purposes of this study, the Team paired the discontinuous, batch-flow type (AD-D) system with electricity generation and the continuous, plug-flow type (AD-C) AD system with CNG generation. The AD-C system produces almost 30% more biogas than the AD-D system, therefore is categorized as a more advanced technology due to the increase in energy recovery. As shown in the team's feedstock study, the City and UCD feedstocks contain roughly 2% food waste. Since this data was collected at the onset of the City's organics collection program, and it is reasonable to assume the percentage of food waste will increase over time. For the purposes of this pro forma and biogas generation, the Team used a value of 2% foodwaste for incoming feedstock to the AD system. This is a most conservative approach.

The value of the electricity was determined by using the weighted average of the price per kilowatt-hour (kwh) over the City WWTP's utility bills for the past 11 months. The value of CNG fluctuates based on the value of D5 RIN (Renewable Identification Number) and LCFS (Low Carbon Fuel Standard) credits, which this project would be eligible to receive.

**Table 7.3** shows the breakdown of the CNG value expressed in diesel gallon equivalent (DGE). To convert biomethane or natural gas volumes to DGE, heating value basis must be consistent (either HHV or LLV). Therefore, LHV and HHV are used to convert RIN and LCFS values to same basis used for natural gas pricing (\$/MMBtu [HHV basis]).

**Table 7.3 CNG Value Assumptions**

	\$ / MMBtu (LHV basis) <sup>1</sup>	\$ / MMBtu (HHV basis) <sup>2</sup>	\$ / DGE
Natural gas commodity price		3	\$0.41
LCFS credit (\$100/credit)	\$19.22	17.83	\$2.46
D5 RIN @ \$0.75	9	8.35	\$1.15
<b>Value as RNG</b>		<b>29.19</b>	<b>4.03</b>

<sup>1</sup>LHV = Lower Heating Value

<sup>2</sup>HHV = Higher Heating Value

The options for use of the biogas, in this study and pro forma do not include upgrading of the raw biogas to pipeline quality renewable natural gas for utility pipeline injection. This option in the State of California is extremely expensive with stringent gas quality requirements. In recent years, the State has begun to encourage pipeline injections and is offering financial incentives, however, the current requirements make this option nearly infeasible for a project of this size. The ideal situation would be for the City to fuel its own truck fleet, or other third-party vehicles at a CNG fueling station at the WWTP.



### 7.2.2 UC Davis Located Options

**Table 7.4** displays the key financial points for a project at the UC Davis location.

**Table 7.4 UC Davis Project Key Financial Points**

OPTION	CAPEX	\$ / TON	REVENUE / UNIT	ANNUAL REVENUE <sup>1</sup>	# OF STAFF
E	\$982,000	\$19.69	Compost: \$20/ton	<b>\$339,682</b>	4.5
F	\$3,996,000	\$44.20	Compost: \$20/ton	<b>\$339,682</b>	3.5

<sup>1</sup>Annual revenue is from compost product sales.

#### *Options E and F – Stand-Alone Composting*

Options E and F have identical cost estimates as Options A and B, respectively. This is due to the assumption that there is no cost to the City to operate a composting operation on land owned by UC Davis. If such a fee were imposed, the net \$/ton cost would increase accordingly.

### 7.2.3 Additional Project Scenarios

Per the City's request, the Team generated financial pro forma for three other project scenarios:

- Project with City and UC Davis feedstock with the removal of recovered C&D materials as potential City-generated feedstock
- Project with only City Feedstock
- Project with four times the City feedstock to represent a large-scale regional project

These additional project scenarios are for planning purposes only, with the intent to provide the City with a yardstick with which to compare future organics projects with existing costs, and other options. The team did not obtain equipment procurement nor construction bids for these systems.

**Table 7.5** on the following page summarizes the net cost per ton from these additional project scenarios, and the original pro forma included in this feasibility study. These full financial pro formas are in **Appendix F**.

As shown in **Table 7.5**, each option is consistent with economies of scale and shows a cost advantage when the feedstock quantity is increased, and a cost disadvantage when the feedstock quantity is decreased. For the City organics only, this assumes two percent foodwaste and 98% greenwaste. For the four times City organics, this still assumes two percent foodwaste and 98% greenwaste. It is important to note that Options A, B, E, and F are for composting only, while Options C and D are for an integrated AD and composting facility.

**Table 7.5 Additional Project Scenarios Net Cost per Ton Comparison**

PROJECT	TECH	CITY + UCD; with C&D; ORIGINAL PROFORMA	CITY + UCD; NO C&D	CITY ORGANICS ONLY	FOUR TIMES CITY ORGANICS
<b>TONS PER DAY Options A, B, E, F (Stand-Alone composting)</b>		<b>96.5</b>	<b>95</b>	<b>48</b>	<b>192</b>
<b>TONS PER DAY Options C &amp; D (AD with composting)</b>		<u>AD</u> <b>53.5</b> <u>Composting</u> <b>83</b>	<u>AD</u> <b>53</b> <u>Composting</u> <b>82.75</b>	<u>AD</u> <b>48</b> <u>Composting</u> <b>36</b>	<u>AD</u> <b>192</b> <u>Composting</u> <b>144</b>
City WWTP (\$/ton)	A) Static Pile Composting	\$19.69	\$20.22	\$31.10	\$12.06
	B) CASP Composting	\$46.06	\$47.02	\$70.80	\$37.78
	C) AD-D + Static Pile Composting	\$77.66	\$79.31	\$144.90	\$95.83 <sup>1</sup>
	D) AD-C + CASP	\$123.03	\$125.85	\$226.04	\$106.62 <sup>1</sup>
UC Davis <sup>2,3</sup> (\$/ton)	E) Static Pile Composting	\$19.69	\$20.22	N/A	\$12.06
	F) CASP	\$46.06	\$47.02	N/A	\$37.78

<sup>1</sup>Although this option has more feedstock going to the AD system than the “City + UCD” options, it does not include some UC Davis material that would be sent directly to the composting operation. The economy of scale for this option is evident by comparing it with the “City Organics Only” proforma.

<sup>2</sup>This assumes a City-operated composting project on UC Davis property.

<sup>3</sup>These proforma do not include potential lease payments for use of UC Davis land.

## Section 8

# Greenhouse Gas Analysis

This greenhouse analysis consists of two parts: (1) U.S. Environmental Protection Agency Waste Reduction Model (WARM); and (2) anaerobic digestion (AD) energy balance.

### 8.1 WARM ANALYSIS

The Waste Reduction Model (WARM) was used to determine the GHG emissions for the baseline and the following three organics waste management scenarios:

1. All organics to landfill for disposal;
2. All organics to composting; and
3. Digestible organics to an AD system with the remainder plus AD digestate to composting.

**Table 8.1** summarizes the results of this analysis. A detailed discussion of the WARM analysis is located in **Appendix G**.

**Table 8.1 Annual Metric Tons of Carbon Dioxide Equivalent (MTCO<sub>2</sub>E) Generated or Reduced Determined by WARM**

WASTE MANAGEMENT SCENARIO	ANNUAL GHG EMISSIONS (MTCO <sub>2</sub> E)		
	City	UCD	Combined
Feedstock Generator			
1. Landfill Disposal	2,772.63	2,801.51	5,574.14
2. Composting	-2,049.80	-2,071.15	-4,120.95
3. AD with Composting	-	-	-3,946.54

### 8.2 AD ENERGY BALANCE

The AD energy balance involved a literature review to determine AD system energy input requirements for the following AD system options evaluated in this report:

- AD discontinuous producing electricity with windrow composting (Option C); and
- AD continuous producing electricity with aerated static-pile composting producing compressed natural gas for vehicle fuel (Option D)

**Table 8.2** summarizes the results of the AD analysis and composting operations energy requirements. A detailed discussion of the AD energy balance is included in **Appendix H**. **Appendix I** includes the detailed discussion of the composting energy requirements.

**Table 8.2 Anaerobic Digestion and Composting Operations Net Energy**

	Units	Option 3 AD-D w/ power production	Option 4 AD-C w/ CNG production
Net Energy ( <i>net input</i> , net output)			
Diesel	gallons/yr	39,575	12,994
Heat	MMBtu/yr	5,438	4,021
Electricity Total	kWh/y	1,339,341	1,227,494
R-CNG	dge/y	N/A	155,198

Each AD option includes a composting component with a throughput of roughly 70 tons per day. It is important to note that the majority of the diesel fuel requirements are due to the composting operations. For example, Option 3 includes windrow composting which requires an estimated 34,496 gallons of diesel per year, roughly 87% of this option's diesel fuel requirements.

In 2017, according to the U.S. Energy Information Administration, the average annual residential home used roughly 10,400 kWh per year of electricity. Using this metric, Option 3 creates enough electricity to power about 129 residential homes. In comparison, Option 4 would require almost the equivalent in electricity, but produce enough renewable CNG to fuel almost 13,000 passenger vehicles. This assumes a fuel tank size of 12 gallons per vehicle.

## Section 9

# Recommendations

As discussed in this report, and summarized in **Table 1.1** in *Section 1, Executive Summary* which is again shared on the following page, the City has several organics processing options that would be financially competitive, and possibly advantageous when compared to the status quo.

Based on this report and the goals of the City, the Clements team recommends the following:

### **If City Organics Only:**

**Recommendation #1:** The City pursue a City-operated static pile composting operation at the City's WWTP.

1. Lowest Cost
2. The City will have full control of their waste and be able to expand this option as needed, including the addition of a small anaerobic digestion system in the future.
3. The City will have control over the product marketing and distribution. The City has several outlets for this material including its residents, schools, landscaping, and parks, as well as the several substantial farming operations in the area.
4. Due to the reduced tonnage, static pile composting most likely will not require the purchase of emissions offsets.
5. This site is adjacent to YCCL, and therefore will have little to no effect on the collection truck hauling costs and GHG emissions.
6. The City would be responsible for the project's CEQA review, giving the City more control over its project.
7. The site has access to utilities and infrastructure. There is an opportunity to use recycled water for operational purposes, and possibly the use of an existing detention pond for stormwater capture and control.

**Recommendation #2:** The City pursue a City-operated CASP composting operation at the City's WWTP

- Lowest cost if greater air emission is required by YSAQMD, or desired by the City and higher cost is not a deterrent
- Benefits #2, #3, and #5 through #7 above.
- CASP composting technologies have achieved significant emission reductions when compared to traditional windrow (static pile) composting, and are consistent with YSAQMD's goals for a BACT technology; no emission offsets would be required.
- These systems also have lower impacts on water quality, easing the process of obtaining the Waste Discharge Requirements (WDR) permit from the Central Valley Regional Water Control Board.

### **If City and UC Davis Organics:**

**Recommendation #3:** The City pursue a City-operated CASP composting operation at the City's WWTP or UC Davis.

CASP Composting System at City WWTP (Option 3.B)

- Same benefits as Recommendation #2

CASP Composting System at UC Davis (Option 4.E)

- Lowest cost if greater air emission is required by YSAQMD, or desired by the City and higher cost is not a deterrent
- The City will have control over the product marketing and distribution. The City has several outlets for this material including its residents, schools, landscaping, and parks, as well as the several substantial farming operations in the area.
- CASP composting technologies have achieved significant emission reductions when compared to traditional windrow (static pile) composting, and are consistent with the Yolo-Solano Air Pollution Control District's goals for a BACT technology.
- These systems also have lower impacts on water quality, easing the process of obtaining the Waste Discharge Requirements (WDR) permit from the Central Valley Regional Water Control Board.
- The City will have full control of their waste and be able to expand this option as needed.
- This project could strengthen the relationship between the City of Davis and UC Davis.
- Some grading work has been complete.
- Chipping and grinding operations already occur at this site, which may eliminate the need for additional pre-processing equipment and labor.
- In terms of CEQA, because this site is already used for some waste receiving, processing, and storing activities the addition of the composting operation may be less significant than at the City's WWTP. Unlike at the City's WWTP, UC Davis would be the Lead Agency for this project and be responsible for the CEQA review.

### **If other organics are available:**

**Recommendation #4:** Once composting is established and particularly if significant amounts of foodwaste are received in the future, consider the addition of AD to augment the existing composting.

**Recommendation #5:** Were the City able to attract organics from the region so as to increase the project capacity from 25,000 tons per year to 50,000 tons per year, favorable economics of scale could be achieved for both composting and AD alternatives.

**Table 1.1 City Alternative Projects Summary**

PROJECT	TECH	TYPE	CAPITAL COST (millions)	OPERATING COSTS / YEAR	PRODUCTS GENERATED	PRODUCT REVENUE / YEAR <sup>2</sup>	NET \$ / TON
1) YCCL	Anaerobic Composter Cells	N/A	N/A	N/A	Power Production + Compost	\$0	\$63.00 <sup>3</sup>
2) Old City Landfill	N/A	N/A	N/A	N/A	N/A	N/A	N/A
3) City WWTP	A) Stand-Alone Composting	Covered Static Pile (12-inch compost cover)	\$0.98	\$576,449	Compost	\$339,682	\$19.69
	B) Stand-Alone Composting	CASP (membrane cover)	\$4.26	\$491,560	Compost	\$339,682	\$46.06
	C) AD + Composting	Discontinuous (AD-D) + Covered Static Pile	\$6.60	\$951,353	Power Production + Compost	\$514,932	\$77.66
	D) AD + Composting	Continuous (AD-C) + CASP	\$13.72	\$1,064,998	CNG Fuel + Compost	\$918,049	\$123.03
4) UC Davis <sup>4,5</sup>	E) Stand-Alone Composting	Covered Static Pile	\$0.98	\$576,449	Compost	\$339,682	\$19.69
	F) Stand-Alone Composting	CASP	\$4.26	\$491,560	Compost	\$339,682	\$46.06
5) Recology JPO	Composting	Aerated Static Piles (ASP)	N/A	N/A	Compost	\$0	\$80.00 <sup>6</sup>

<sup>1</sup>The tons per day (TPD) is based on the available organics from both City of Davis and UC Davis and assumes 22 working day per month (264 days per year). Alternative feedstock quantities (i.e., City-only feedstock, four times City feedstock, feedstock without C&D) are assessed in the financial proformas in *Appendix E*.

<sup>2</sup>This annual revenue only represents the revenue from the technology byproducts which the City controls.

<sup>3</sup>This tip fee was provided by Yolo County Central Landfill (YCCL); YCCL developed this estimated tip fee late 2016, and at the time of this report has yet to provide an updated tip fee.

<sup>4</sup>This assumes a City-operated composting project on UC Davis property.

<sup>5</sup>This pro forma does not include potential lease payments for use of UC Davis land.

<sup>6</sup>This is an average of typical Recology JPO organics tip fees, not a City-negotiated price.

## Section 10

### Next Steps

Based on the findings in this feasibility study, the Clements team recommends the following next steps:

- Meet with UC Davis and adjacent municipalities to determine interest and commitment  
Project finances improve with economies of scale. This is evident in the additional financial pro formas (**Appendix F**) which evaluate a “City only” project versus a regional project four times the size.
- Meet with the Yolo-Solano Air Quality Management District (YSAQMD)  
Meet with YSAQMD to discuss plans for rule adoption in the future and critical issues such as thresholds above which emission offsets would be required and the cost and availability of these offsets. YSAQMD does not currently have an organics composting rule regarding air emissions, but requires Best Available Control Technology (BACT) for any proposed composting operation.
- Meet with Yolo County  
The Yolo County Central Landfill’s project is on the cusp of operations and does not currently have any organic waste agreements. The City may be able to negotiate a favorable deal if it is one of the first municipalities to come to the table.
- Meet with Recology, Inc.  
At the time of this report, Recology, Inc. stated that its nearest composting facility, Jepson Prairie Organics (JPO), is operating at half its permitted capacity. The City may be able to negotiate a favorable arrangement with Recology to use JPO.
- Consider issuing an RFQ/RFP for composting vendors for the preferred organics management option.



# **APPENDICES**

<b>APPENDIX A</b>	<b>YCCL July 2018 Solid Waste Facility Permit</b>
<b>APPENDIX B</b>	<b>YCCL Waste Flow Diagram</b>
<b>APPENDIX C</b>	<b>YCCL Follow-up Tech. Memo.</b>
<b>APPENDIX D</b>	<b>Recology Davis Follow-up Tech. Memo.</b>
<b>APPENDIX E</b>	<b>Alternative Project's Financial Pro Forma</b>
<b>APPENDIX F</b>	<b>Additional Financial Pro Forma Scenarios</b>
<b>APPENDIX G</b>	<b>Project WARM Analysis</b>
<b>APPENDIX H</b>	<b>Composting Operations Energy Requirements Tech. Memo.</b>
<b>APPENDIX I</b>	<b>Anaerobic Digestion Energy Balance Tech. Memo.</b>

# **APPENDIX A**

**YCCL July 2018**

**Solid Waste Facility Permit**

# SOLID WASTE FACILITY PERMIT

Facility Number:

**57-AA-0001**

**1. Name and Street Address of Facility:**

Yolo County Central Landfill  
44090 CR 28H  
Woodland, CA 95776

**2. Name and Mailing Address of Operator:**

Yolo County Community Services Dept.  
Division of Integrated Waste Management  
44090 CR 28H  
Woodland, CA 95776

**3. Name and Mailing Address of Owner:**

Yolo County Community Services Dept.  
Division of Integrated Waste Management  
44090 CR 28H  
Woodland, CA 95776

**4. Specifications:**

- a. Permitted Operations:**  Solid Waste Disposal Site  In-Vessel Digester (IVD)  
 Composting Facility # 1 (CF1)  Composting Facility #2 (CF2)  
 Construction, Demolition, Inert (CDI) and Materials Processing Facility (MPF)

- b. Permitted Hours of Operation:** 6:00 a.m. to 5:00 p.m., Monday to Saturday  
 7:00 a.m. to 6:00 p.m., Sunday  
**Closed:** New Year's Day, Easter Sunday, Independence Day, Labor Day, Thanksgiving Day, Christmas Day

- c. Permitted Maximum Tonnage:** 1800 Tons per Day

- d. Permitted Traffic Volume:** 1047 Vehicles per Day

- e. Key Design Parameters (Detailed parameters are shown on site plans bearing EA and CalRecycle validations):**

	Total	Disposal	CDI/MPF	CF1	CF2	IVD
Permitted Area (acres)	724.54	473	10	21	38	2.3
Design Capacity		49,035,200 yd <sup>3</sup>	57,000 yd <sup>3</sup>	161,000 yd <sup>3</sup>	208,000 yd <sup>3</sup>	3,360,000 gallons
Max Elevation (Ft. MSL)		141.4				
Estimated Closure Year		2124				

Upon a significant change in design or operation from that described herein, this permit is subject to revocation or suspension. The attached permit findings and conditions are integral parts of this permit and supersede the conditions of any previously issued solid waste facility permit.

**5. Approval:**

  
 Approving Officer Signature  
 April Meneghetti, REHS  
 Acting Director of Environmental Health

**6. Enforcement Agency Name and Address:**

Yolo County Environmental Health  
 292 W. Beamer Street  
 Woodland, CA 95695

**7. Date Received by CalRecycle:** July 9, 2018

**8. CalRecycle Concurrence Date:** July 30, 2018

**9. Permit Issued Date:**

July 31, 2018

**10. Permit Review Due Date:**

July 31, 2023

**11. Owner/Operator Transfer Date:**

N/A

# SOLID WASTE FACILITY PERMIT

Facility Number:

**57-AA-0001**

## 12. Legal Description of Facility:

The legal description of this facility is contained in Appendix F of the Joint Technical Document, dated April 2018.

## 13. Findings:

- a. This permit is consistent with the Yolo County Integrated Waste Management Plan, which was approved by CalRecycle on May 15, 2002. The location of the facility is identified in the Countywide Siting Element, pursuant to Public Resources Code (PRC), Section 50001(a).
- b. This permit is consistent with the standards adopted by CalRecycle, pursuant to PRC 44010.
- c. The design and operation of the facility is consistent with the State Minimum Standards for Solid Waste Handling and Disposal as determined by the enforcement agency, pursuant to PRC 44009.
- d. The City of Davis Fire Department has determined that the facility is in conformance with applicable fire standards, pursuant to PRC, 44151.
- e. A Subsequent Environmental Impact Report (SEIR) was filed with the State Clearinghouse (SCH #1991073040) and certified by the County of Yolo Board of Supervisors on September 27, 2005. Addendums #3 and #4 to the SEIR were prepared by the Yolo County Community Services Department in April 2017 and February 2018 respectively. The Subsequent EIR and Addendums describe and support the design and operation of the facility, which will be authorized by the issuance of this permit.

## 14. Prohibitions:

The permittee is prohibited from accepting the following wastes:

Hazardous, radioactive, medical (as defined in Sections 117600 – 118360 of the Health and Safety Code), liquid, designated, or other wastes requiring special treatment or handling, except as identified in the Report of Facility Information and approved amendments thereto and as approved by the enforcement agency.

## 15. The following documents describe and/or restrict the operation of this facility:

	Date		Date
Joint Technical Document and Amendments	6/2018	Partial Final Closure and Post Closure Maintenance Plan (WMU 1-5)	8/2017
		Preliminary Closure and Postclosure Maintenance Plan (WMU 6-7)	8/2017
Environmental Impact Report (SCH#1991123015)	10/27/1992	APCD Permit to Operate #	Various (see JTD)
Mitigated Negative Declaration (SCH#1992073008) and (SCH#1994103016)	2/19/1993	Operating Liability Certification	3/1/2017
	3/23/1995		
Tiered Negative Declaration (SCH#1999062043)	6/22/1999	Closure Financial Assurance Documentation	8/25/2016
Negative Declaration (SCH#2000022095)	6/15/2000	Land Use and/or Conditional Use Permit	4/21/2006
Subsequent Environmental Impact Report (EIR) (SCH#1991073040)	9/27/2005	Waste Discharge Requirements (R5-2002-0078) (R5-2016-0094)	4/26/2002 12/14/2016
Addendum #3 to SEIR (SCH#1991073040)	4/2017	Notices of Exemption	11/5/1992
Addendum #4 to SEIR (SCH#1991073040)	2/2018		5/15/2000 3/29/2011

# SOLID WASTE FACILITY PERMIT

Facility Number:

**57-AA-0001**

## 16. Self Monitoring:

The owner/operator shall submit the results of all self monitoring programs to the Enforcement Agency within 30 days of the end of the reporting period (for example, 1<sup>st</sup> quarter = January – March, the report is due by April 30, etc.. Information required on an annual basis shall be submitted with the 4<sup>th</sup> quarter monitoring report, unless otherwise stated.)

Program	Reporting Frequency
a. The types and quantities (in tons) of waste, including separated or commingled recyclables, entering the facility per day.	Monthly
b. The number and types of vehicles using the facility per day.	Annually
c. Results of the hazardous waste load checking program, including the quantities and types of hazardous wastes, medical wastes or otherwise prohibited wastes found in the waste stream and the disposition of these materials.	Annually
d. Copies of all written complaints regarding this facility and the operator's actions taken to resolve these complaints.	Within seven (7) calendar days
e. Results of the landfill gas monitoring program.	Quarterly
f. Wet weather preparedness report/winter operations plan.	Annual – due by November 1
g. Fill sequencing plan for the forthcoming year.	Annually
h. Remaining site capacity.	Annually
i. Groundwater Monitoring Report.	Semi-annual
j. Summary and analytical data confirming the presence of chemical constituents not previously defined.	Ten (10) working days
k. Report to the enforcement agency via phone or electronic mail of any special occurrences that include but are not limited to: fires, explosions, earthquakes, accidents, property damage, significant injuries, unauthorized dumping, equipment failures, and operation difficulties and corrective action taken.	Within twenty-four (24) hours
l. Records of the types and quantities (cubic yards) of compostable materials entering each discrete composting unit per day.	Available upon request
m. Records of all pathogen reduction results and acceptable metal concentrations limits with lab analysis and physical contaminants for each discrete composting unit.	Per JTD
n. Bioreactor-specific monitoring and testing results.	Per JTD
o. In-Vessel Digestion-specific monitoring and testing results.	Per JTD

# SOLID WASTE FACILITY PERMIT

Facility Number:

**57-AA-0001**

## 17. Enforcement Agency (EA) Conditions:

- a. The operator shall comply with all State Minimum Standards for solid waste handling and disposal as specified in Titles 14 and 27, California Code of Regulations.
- b. The operator shall maintain a log of special/unusual occurrences. This log shall include, but is not limited to, fires, explosions, the discharge and disposition of hazardous or unpermitted wastes, and significant injuries, accidents or property damage. Each log entry shall be accompanied by a summary of any actions taken by the operator to mitigate the occurrence. The log shall be available to site personnel and the EA at all times.
- c. Additional information concerning the design and operation of the facility shall be furnished upon request and within the timeframe specified by the EA.
- d. The maximum permitted daily tonnage for this facility is 1,800 tons per day. The facility shall not receive more than this amount without a revision of this permit.
- e. The maximum permitted tonnages for each operation are specified in the JTD.
- f. This permit is subject to review by the EA and may be temporarily suspended or revoked at any time by the LEA for sufficient cause, in accordance with Division 30 of the Public Resource Code, Part 4, Chapter 4, Article 2, Sections 44305 et seq. and associated regulations.
- g. The EA reserves the right to suspend or modify waste receiving and handling operations when deemed necessary due to an emergency, a potential health hazard, or the creation of a public nuisance.
- h. Any change that would cause the design or operation of the facility not to conform to the terms and conditions of this permit is prohibited. Such a change may be considered a significant change, requiring a permit revision. In no case shall the operator implement any change without first submitting a written notice of the proposed change, in the form of a JTD amendment, to the EA at least 180 days in advance of the change.
- i. A copy of this permit shall be maintained at the facility.
- j. The drop-off recycling area will be cleaned weekly.
- k. The removal of metal recyclables at the metal recovery area shall be as described in the JTD by the EA.
- l. Dewatered sewage sludge, grits, and screenings may only be accepted Monday through Friday before 9:00 a.m.
- m. Containers at the recycling drop-off area will be removed when full or more frequently as determined by the EA.
- n. Per Title 27 CCR Section 20070(f), permitting of the RD&D components may be renewed for successive three year intervals for a total permit time period not to exceed twelve years.
- o. Per Title 27 CCR Section 20070(d), the EA may order an immediate termination of all RD&D related operations as described in the JTD, or other corrective measures, at any time either agency determines the overall goals of the project are not being attained, including protection of public health and safety or the environment.

# **APPENDIX B**

## **YCCL Waste Flow Diagram**

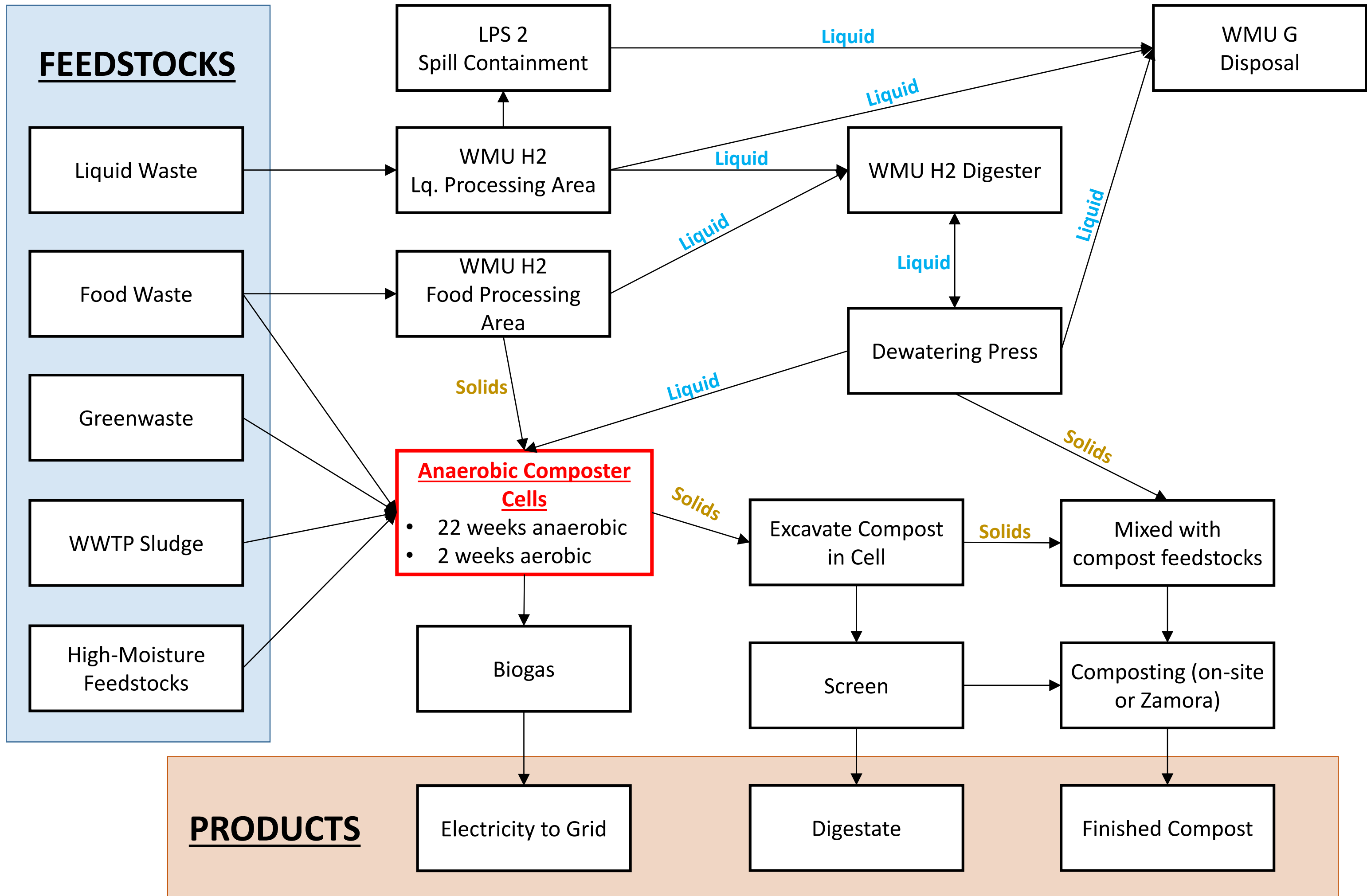



# **APPENDIX C**

## **YCCL Follow-up Tech. Memo.**

---

# YOLO COUNTY CENTRAL LANDFILL FOLLOW-UP

## TECHNICAL MEMORANDUM

---

September 2018

Prepared for: City of Davis  
Prepared by: Clements Environmental Corp.

This Technical Memo was prepared to summarize the discussions from a conference call on Tuesday, September 25, 2018 between Ramin Yazdani, Yolo County, Jennifer Gilbert, City of Davis, and Cindy Liles, Clements Environmental Corp.

### **1. YOLO COUNTY CENTRAL LANDFILL PROJECT UPDATES**

Yolo County currently has three organic waste projects in the permitting and development phases at their Yolo County Central Landfill (YCCL).

Project 1	Anaerobic Composter Cells (Composting Facility #1) (CF #1)
Project 2	Aerobic Composting Facility (Composting Facility #2) (CF #2)
Project 3	Liquid and Food Processing Building

#### *Project 1: Anaerobic Composter Cells*

Phase One of the anaerobic composter (AC) cells is currently in the construction phase. The Central Valley Regional Water Quality Control Board (Regional Water Board) must approve the project's construction quality assurance (CQA) plan prior to operation. The Regional water Board has 90 days to review and approve/comment on the CQA from submittal. Yolo County estimated time to operations is early 2019 with a goal of January 2019.

Phase One is sized to process 52,000 tons per year, or roughly 175 tons per day. Phase Two of the project will be constructed summer 2019 to provide a total throughput of 110,000 tons per year, or roughly 366 tons per day.

The estimated tipping fee for this project has remained at \$63 per ton since November 2017. This estimation was based on several assumptions, the most significant of which is the percent of foodwaste in the received feedstock. Yolo County believes they assumed five percent foodwaste. The current plan is to use this estimated tip fee for the first six months of the project, then Yolo County will reassess if this is the appropriate fee.

Project 2: Aerobic Composting Facility

Yolo County has modified its Solid Waste Facility Permit to include Northern Recycling's composting operation, which is proposed to be an Engineered Compost Systems (ECS) aerated static pile (ASP) composting system. However, upon review of the revised Joint Technical Document (JTD), the JTD revised June 2018 states that this project is "in the future" and is estimated to occur within the next five years.

The other two environmental permits Northern Recycling needs prior to operated are compliance with the Waste Discharge Requirements for Composting Facilities (WDR) and an Authority to Construct (ATC) Air Permit.

Northern Recycling has officially submitted its application to the Yolo Solano Air Quality Management District, but no permit has been issued.

The Regional Water Board requires this project to build a levee around the entire composting operation to protect from the 100-year flood, as the operation is located within the flood plain. Northern Recycling and YCCL proposed to relocate the project on part of the closed landfill, but CalRecycle denied the request because the potential impacts (e.g. compaction, leakage, etc.) with building on non-native soil have not been evaluated in the project's CEQA.

There is no estimated tip fee for this project. Originally, Northern Recycling estimated a \$40 per ton tip fee, but has since moved into the \$70 per ton range. Yolo County anticipates this project's tip fee will be larger than Project One.

A major hurdle for this project is that Northern Recycling cannot obtain proper financing. It is apparent that this project needs long-term feedstock contracts for financing, however only one letter of intent has been received from the City of West Sacramento. YCCL and Northern Recycling have approached Sacramento County and City of Sacramento.

Yolo County anticipates this project will be built late-2020. As stated, this is dependent on receiving feedstock contracts. This project is sized for a maximum of 180,000 per year, roughly 600 tons per day, which Yolo County believes is very attainable. For example, Sacramento County alone is estimated to generate 200,000 tons per year. An estimated 10,000 to 15,000 tons of organics will be hauled from outside Yolo County to this project; this is based on tonnage Northern Recycling is currently processing in Zamora.

This project is estimated at roughly \$28 million, plus an additional two million for the levee. Yolo County estimates this includes a \$10 million dollar building plus \$10 million aeration composting system, with some funds allocated to the construction of a lined leachate pond.

Project 3: Liquid and Food Processing Building

The YCCL liquid and food processing building is anticipated to start-up summer 2019. YCCL awarded an equipment contractor September 2018, and expects to receive the equipment in six months. An additional three months is necessary to install and test equipment prior to full operation.

**2. CITY PARTICIPATION IN YCCL ORGANICS PROJECT**

Yolo County is not worried about meeting tonnage requirements for its organics project(s), but would like to know when cities will decide to commit. Ideally, YCCL wants a long-term feedstock contract and is open to 5-year, 10-year, 20-year, and beyond commitments. The longer-term agreements will receive better rates than the shorter-term agreements.

The following descriptions clarify where exactly the City's organic waste will be sent if it participates in the YCCL organics project:

Current organics waste flow at YCCL:

If greenwaste only	→ Northern Recycling in Zamora (YCCL extended Northern's contract by one (1) year)
If any foodwaste	→ NAPA Composting
C&D inerts	→ Sacramento
C&D drywall	→ Northern Recycling in Zamora
C&D wood	→ YCCL construction of Project #1

After Project #1 is up and running:

If greenwaste only	→ Northern Recycling in Zamora
If any foodwaste	→ Project #1

After Project #1 and Project #2 are up and running:

If mostly greenwaste	→ Northern Recycling @ YCCL
If mostly foodwaste	→ CF #1

**3. YCCL PARTICIPATION IN CITY-OWNED AND OPERATED ORGANICS PROJECT**

In order for YCCL to consider participation in a City-owned and/or operated organics project, the City needs to identify what are the potential benefits to YCCL.

To date, YCCL has invested a substantial amount of money and time on the permitting and development of its organics projects to provide organic waste solutions to the region. YCCL believes use of these projects are in the best interested of the cities, as all the heavy lifting and financial investments have already been completed.

YCCL does not depend on its partnership with Northern Recycling to ensure the success of Project #2, but this partnership offered two major advantages:

1. Northern Recycling owns NH<sub>4</sub> and VOC emission reduction credits (offsets) that can transfer to the YCCL site. The Yolo Solano air district does not have many offsets, and the ones that exist may not be available to purchase.
2. County has interest in closing the Zamora site due to odor complaints. End to the windrow composting operation and construction of a state-of-the-art aerated composting system.

A third, but minor advantage is that Northern Recycling will bring with it some material that originates outside the County. The County will be able to impose an additional fee on this material.

YCCL is aware that the University of California, Davis is also looking at possible collaboration with the City on an organics project, or the development of its own composting facility. Again, YCCL believes its organics project is in the best interested of the surrounding cities, including UC Davis.

YCCL is currently conducting a research project with UC Davis to have in-place aeration within the anaerobic composter cell.

#### **4. FOLLOW-UP QUESTIONS**

##### *Does YCCL need aerobic composting for post-processing Project #1 digestate?*

Worst case scenario – Yes, the post-digestate from Project #1 will be sent to Zamora for “short term” curing; five (5) days at 131 degrees to ensure pathogen reduction.

Moderate case – Post-digestate can be cured onsite at YCCL on a pad.

Best case – The in-place aeration is successful

##### *Is YCCL open to any other possible collaboration with the City?*

Yes, there is an opportunity for wood and biosolids treatment. Currently, YCCL receives about 3,000 tons per year of biosolids and biosolids can only be applied 10 to 20 tons per acre. YCCL is interested in exploring gasification as a solution to this problem. NAPA/Northern Recycling are planning on building a one (1) MegaWatt gasifier for wood waste. Public utilities are currently paying a premium for renewable energy at \$0.18 to \$0.20 per kwh.

## **APPENDIX D**

**Recology Davis Follow-up Tech. Memo.**



---

# RECOLOGY DAVIS AND RECOLOGY'S ORGANICS INFRASTRUCTURE

---

October 2018

Prepared for: Clements Environmental, Corp.  
Prepared By: Diversion Strategies

Since the initial Organics Feasibility Report last year, Recology has acquired Davis Waste Removal. The acquisition was finalized in April 2018. The City has an exclusive franchise waste agreement with Recology Davis (and formerly with Davis Waste Removal) to collect materials, including organics, within the city limits.

## **Recology Overview**

Recology is a waste and resource recovery company, based in San Francisco, California. As a 100% employee owned company, it serves 127 communities throughout California, Oregon and Washington. Recology is vertically integrated, covering operations from collection and hauling, transfer stations and material recovery facilities, compost facilities, and landfills.

In April 2018, Recology purchased Davis Waste Removal. Included in the acquisition was the hauling and collection assets, the recycling center on Second Street and a green waste transfer/chip & grind operation on County Road 105D.

## **Current Davis Organics Status**

Organics collected from the City of Davis go to Yolo County Central Landfill (YCCL) for consolidation and transfer to a permitted compost facility. At the time of the initial feasibility report, organics were being transferred to Zamora for composting. As of our June 2018 interview with Recology, organics at the YCCL were being transferred to Napa.

As part of the acquisition, Recology received a green waste transfer and chip & grind operation. While the permit is active, it appears that this facility is only used at times when the YCCL is closed.

## Recology's Organics Infrastructure

Recology operates compost facilities in California and Oregon. In Northern California, Recology owns and operates three compost facilities which are in proximity to City of Davis. These sites are described in more detail below.

### 1. Jepson Prairie Organics

Recology's closest compost facility to City of Davis is the Jepson Prairie Organics ("JPO") composting facility in Vacaville, California. This site is co-located at Recology's Hay Road Landfill, in Solano County, approximately 18 miles from Davis.



JPO is permitted to receive both green and food materials for composting, including commercial and residential derived food material streams. The site is permitted to receive up to 600 tons per day (average), with a peak tonnage limit of 750 tons per day.

### 2. Feather River Organics/Recology Ostrom Road

Recology owns and operates the Feather River Organics ("FRO") green and food materials composting facility at its transfer station in Marysville, CA. This facility is located at the Recology Yuba Sutter transfer station. This site is permitted to receive up to 400 tons per day. The FRO facility is located in Yuba County, approximately 55 miles from City of Davis.

The FRO composting facility will eventually be relocated to Recology's Ostrom Road Landfill. Recology is currently in the permitting process to construct a compost facility adjacent to the landfill. The proposed compost facility will be constructed in phases, up to a total of 2,000 tons per day, receiving both food and green materials for composting. The Recology Ostrom Road facility is located in Yuba County, approximately 50 miles from City of Davis.

### 3. Blossom Valley Organics North Vernalis

The Blossom Valley Organics North - Vernalis (BVON) composting facility is owned and operated by Recology, and is located in Vernalis, California. The BVON composting facility is



permitted to accept up to 2,000 tons per day of food and green materials for composting. The BVON facility is located in San Joaquin and Stanislaus Counties, approximately 85 miles from City of Davis.

### **Recology Interview**

On June 20, 2018, Erin Merrill, Rachel Oster of Diversion Strategies met with Jennifer Gilbert from City of Davis and Sal Coniglio, Scott Pardini, Justina Vega from Recology Davis. The purpose of the meeting was to talk with Recology Davis about plans for organics following the acquisition of Davis Waste Removal (“DWR”) in April 2018.

Since acquiring DWR, the organics collections routes as described in the Feedstock Assessment have remained the same. At the time of our interview, Recology does not anticipate any changes to routing to segregate the collection of commercial organics from collection of residential organics. At the time of the interview, they had not considered any route optimization evaluation for Davis collection routes.

Under the contract with the City of Davis, Recology must perform 50 waste audits a year. These audits are done in conjunction with the City. In an effort to reduce contamination, or non-compostable materials in the organics stream, Recology intends to focus on working with customers on better methods to sort the waste at the point of generation. In addition, they will continue to work on public outreach and education with their customers.

Despite Recology’s organics infrastructure in proximity to the City of Davis, the collected organics go to YCCL for consolidation and transfer to a permitted compost facility. Currently the organics are being transferred from YLLC to Napa. This is directed by the City.

According to Recology, there is currently capacity to receive organics at its JPO composting facility near Vacaville. Currently, Recology Davis approximates that JPO is operating at half capacity. Recology Davis has not considered a rate for the processing of organics at JPO for City of Davis. It would be unlikely that BVON would be a possible location for organics from City of Davis due to the hauling distance. More likely, the future composting facility at the Ostrom Road Landfill would be a back-up to JPO, since the Ostrom facility would be closer than BVON.

# **APPENDIX E**

## **Alternative Project Financial Pro Formas**

Basic Assumptions						
	SITE WWTP				SITE UC DAVIS	
	Option A Composting	Option B Composting	Option C AD & Composting AD-D &	Option D AD & Composting	Option E Composting	Option F Composting
	Covered Static Pile	CASP	Covered Static Pile	AD-C & CASP	Covered Static Pile	CASP
<b>Incoming Tons</b>						
TPD	96.5	96.5	96.5	96.5	96.5	96.5
TPY	25,476.0	25,476.0	25,476.0	25,476.0	25,476.0	25,476.0
<b>Commodity Sales</b>						
Compost TPY	16,984.1	16,984.1	14,630.1	14,630.1	16,984.1	16,984.1
Electricity kWh			1,339,341			
CNG Diesel gallon Equivalent				155,198		
<b>Personnel</b>	4.5	3.5	7.0	7.0	4.5	3.5
<b>Equipment</b>						
Trommel	1.0	1.0	1.0	1.0	1.0	1.0
Tub Grinder	1.0	1.0	1.0	1.0	1.0	1.0
Storage Tank	1.0		1.0		1.0	
CASP		1.0				1.0
Loader	1.0	1.0	1.0	1.0	1.0	1.0
Cover Winder		1.0		1.0		
AD-D			1.0			
Gas Cleanup			1.0	1.0		
Pipeline Connection			1.0	1.0		
AD-C				1.0		
Water Truck	1.0		1.0		1.0	
<b>Facility</b>						
Site Prep & Storm Water	1.0	1.0	1.0	1.0	1.0	1.0
Building				1.0		
Scale	1.0	1.0	1.0	1.0	1.0	1.0

## Financial Proforma

	SITE - WWTP						SITE - UC DAVIS					
	Option A Composting		Option B Composting		Option C AD & Composting AD-D & Covered Static Pile		Option D AD & Composting AD-C & CASP		Option E Composting		Option F Composting	
	Covered Static Pile		CASP		Covered Static Pile		AD-C & CASP		Covered Static Pile		CASP	
	\$ Per Incoming ton      Annual		\$ Per Incoming ton      Annual		\$ Per Incoming ton      Annual		\$ Per Incoming ton      Annual		\$ Per Incoming ton      Annual		\$ Per Incoming ton      Annual	
<b>Operations Costs</b>												
Labor	\$17.05	\$434,417	\$13.78	\$351,184	\$26.86	\$684,321	\$27.46	\$699,622	\$17.05	\$434,417	\$13.78	\$351,184
Equip Maint & Ops	\$5.58	\$142,032	\$5.51	\$140,376	\$10.48	\$267,032	\$14.34	\$365,376	\$5.58	\$142,032	\$5.51	\$140,376
<b>Sub-Total</b>	<b>\$22.63</b>	<b>\$576,449</b>	<b>\$19.29</b>	<b>\$491,560</b>	<b>\$37.34</b>	<b>\$951,353</b>	<b>\$41.80</b>	<b>\$1,064,998</b>	<b>\$22.63</b>	<b>\$576,449</b>	<b>\$19.29</b>	<b>\$491,560</b>
<b>Disposal Costs <sup>1</sup></b>												
Disposal - Residual Solid Waste Recovered/Diverted w/Negative Value	\$0.00	-	\$0.00	-	\$0.00	-	\$0.00	-	\$0.00	-	\$0.00	-
<b>Sub-Total</b>	<b>\$0.00</b>	<b>\$0</b>	<b>\$0.00</b>	<b>\$0</b>	<b>\$0.00</b>	<b>\$0</b>	<b>\$0.00</b>	<b>\$0</b>	<b>\$0.00</b>	<b>\$0</b>	<b>\$0.00</b>	<b>\$0</b>
<b>General &amp; Administrative Costs <sup>2</sup></b>												
Personnel <sup>3</sup>												
Facility G&A	\$1.98	\$50,400	\$1.98	\$50,400	\$1.98	\$50,400	\$1.98	\$50,400	\$1.98	\$50,400	\$1.98	\$50,400
<b>Sub-Total</b>	<b>\$1.98</b>	<b>\$50,400</b>	<b>\$1.98</b>	<b>\$50,400</b>	<b>\$1.98</b>	<b>\$50,400</b>	<b>\$1.98</b>	<b>\$50,400</b>	<b>\$1.98</b>	<b>\$50,400</b>	<b>\$1.98</b>	<b>\$50,400</b>
<b>Debt Service &amp; Equipment Replacement</b>												
Debt Service <sup>4</sup>	\$4.97	126,531	\$21.55	549,120	\$33.04	841,836	\$66.47	1,693,452	\$4.97	126,531	\$21.55	549,120
Equipment Replacement	\$3.45	\$87,857	\$16.57	\$422,143	\$25.51	\$649,857	\$48.81	\$1,243,443	\$3.45	\$87,857	\$16.57	\$422,143
<b>Sub-Total</b>	<b>\$8.42</b>	<b>\$214,388</b>	<b>\$38.12</b>	<b>\$971,263</b>	<b>\$58.55</b>	<b>\$1,491,694</b>	<b>\$115.28</b>	<b>\$2,936,895</b>	<b>\$8.42</b>	<b>\$214,388</b>	<b>\$38.12</b>	<b>\$971,263</b>
<b>Total Costs</b>	<b>\$33.02</b>	<b>\$841,237</b>	<b>\$59.40</b>	<b>\$1,513,223</b>	<b>\$97.87</b>	<b>\$2,493,447</b>	<b>\$159.06</b>	<b>\$4,052,293</b>	<b>\$33.02</b>	<b>\$841,237</b>	<b>\$59.40</b>	<b>\$1,513,223</b>
<b>Revenue from Commodity Sales</b>	\$13.33	\$339,682	\$13.33	\$339,682	\$20.21	\$514,932	\$36.04	\$918,049	\$13.33	\$339,682	\$13.33	\$339,682
<b>Net Cost</b>	<b>\$19.69</b>	<b>\$501,555</b>	<b>\$46.06</b>	<b>\$1,173,541</b>	<b>\$77.66</b>	<b>\$1,978,515</b>	<b>\$123.03</b>	<b>\$3,134,244</b>	<b>\$19.69</b>	<b>\$501,555</b>	<b>\$46.06</b>	<b>\$1,173,541</b>
<b>Incoming Tons</b>	25,476		25,476		25,476		25,476		25,476		25,476	

Notes

1. Assumes no disposal costs.
2. General and administrative costs are expenses required to administer a business, and which are not related to the construction, production or sale of goods or services.
3. No General & Administrative staff is included in this Pro-Forma.
4. This represents principal and interest.

### Incoming Tonnage & Products Generated

				Option A	Option B	Option C			Option D			Option E	Option F
				Composting	Composting	AD & Composting			AD & Composting			Composting	Composting
				Covered Static Pile	CASP	AD-D & Covered Static Pile			AD-C & CASP			Covered Static Pile	CASP
City of Davis	TPD	TPY	%	Compost	Compost	Compost	Electricity	Total	Compost	CNG	Total	Compost	Compost
Mixed GW & FW	26.00	6,864.0	54.2%										
GW Loose	18.0	4,752.0	37.5%										
Other Organics	4.0	1,056.0	8.3%										
<b>Total</b>	<b>48.0</b>	<b>12,672.0</b>	<b>100.0%</b>										
<b>UC Davis</b>													
Postconsumer FW	0.50	132.0	1.0%										
Digestate	2.0	528.0	4.1%										
Animal Bedding	41.0	10,824.0	84.5%										
GW	5.0	1,320.0	10.3%										
<b>Total</b>	<b>48.5</b>	<b>12,804.0</b>	<b>100.0%</b>										
<b>GRAND TOTAL</b>	<b>96.5</b>	<b>25,476.0</b>											
Compost Product Tons				16,984	16,984	14,630			14,630			16,984	16,984
Biogas to Electricity Product (kWh)							1,339,341						
Biogas to Fuel Product (Diesel Gallon Equivalent)									155,198				
<b>Revenue per Unit</b>				\$20.00	\$20.00	\$20.00	\$0.166		\$20.00	\$4.03		\$20.00	\$20.00
<b>Commodity Sales Revenue</b>				<b>\$339,682</b>	<b>\$339,682</b>	\$292,601	\$222,331	<b>\$514,932</b>	\$292,601	\$625,448	<b>\$918,049</b>	<b>\$339,682</b>	<b>\$339,682</b>

<b>Incoming Tons</b>	<b>25,476.0</b>	<b>25,476.0</b>	<b>25,476.0</b>		<b>25,476.0</b>		<b>25,476.0</b>
% Tons to Composting Operation	100.0%	100.0%				100.0%	100.0%
<b>Tons to Composting Operation</b>	<b>25,476.0</b>	<b>25,476.0</b>	<b>11,352.0</b>		<b>11,352.0</b>	<b>25,476.0</b>	<b>25,476.0</b>
% Compost Production	66.667%	66.667%	66.7%		66.7%	66.667%	66.667%
Compost Product	16,984.1	16,984.1	7,568.0		7,568.0	16,984.1	16,984.1
<b>Tons to Digester</b>			14,124.0		14,124.0		
Tons to Composting Operation			10,593.0		10,593.0		
% Compost Production			66.7%		66.7%		
Compost Product			7,062.0		7,062.0		
<b>Total Compost Product Tons</b>	<b>16,984.1</b>	<b>16,984.1</b>	<b>14,630.1</b>		<b>14,630.1</b>	<b>16,984.1</b>	<b>16,984.1</b>

**Direct Labor**

OPTION A WWTP - COMPOSTING Covered Static Pile					Annual Hours						Annual Labor Hours			Annual Labor Compensation														
	Regular Hours	OT Hours	Total Weekly Hours	# of Shifts	Total Regular Hours	Total OT Hours	TOTAL HOURS	Crew Size	Total Crew	Total Regular Hours	Total OT Hours	TOTAL HOURS	Regular Rate	OT Rate	Regular Wages	OT Wages	Holiday Wages	Vacation Wages	Sick Leave Wages	Pension	Medical	Total Compensation	WC Factor	WC Rate	WC Expense	Unifor m	Payroll Tax	Wages Expense
Supervisor/GM	20.0	-	20.0	1.00	1,040.0	-	1,040.0	1.00	1.00	880.0	-	880.0	40.00	60.00	35,200	-	2,880	4,800	1,600	2,640	14,400	61,520	445	10.00	4,448	-	5,229	71,197
Equipment Operators	40.0	-	40.0	1.00	2,080.0	-	2,080.0	2.00	2.00	3,840.0	-	3,840.0	30.00	45.00	115,200	-	4,320	7,200	2,400	11,520	28,800	169,440	1,291	10.00	12,912	-	14,402	196,754
Laborer	40.0	-	40.0	1.00	2,080.0	-	2,080.0	2.00	2.00	3,936.0	-	3,936.0	24.00	36.00	94,464	-	3,456	3,840	1,536	11,808	28,800	143,904	1,033	10.00	10,330	-	12,232	166,465
Unused	-	-	-	-	-	-	-	-	-	-	-	-	-	-	-	-	-	-	-	-	-	-	-	-	-	-	-	-
					5,200.0	-	5,200.0	5.00	5.00	8,656.0	-	8,656.0			244,864	-	10,656	15,840	5,536	25,968	72,000	374,864			27,690	-	31,863	434,417
<b>OPTION B</b>																												
<b>WWTP - COMPOSTING</b>																												
<b>CASP</b>																												
Supervisor/GM	20.0	-	20.0	1.00	1,040.0	-	1,040.0	1.00	1.00	880.0	-	880.0	40.00	60.00	35,200	-	2,880	4,800	1,600	2,640	14,400	61,520	445	10.00	4,448	-	5,229	71,197
Equipment Operators	40.0	-	40.0	1.00	2,080.0	-	2,080.0	2.00	2.00	3,840.0	-	3,840.0	30.00	45.00	115,200	-	4,320	7,200	2,400	11,520	28,800	169,440	1,291	10.00	12,912	-	14,402	196,754
Laborer	40.0	-	40.0	1.00	2,080.0	-	2,080.0	1.00	1.00	1,968.0	-	1,968.0	24.00	36.00	47,232	-	1,728	1,920	768	5,904	14,400	71,952	516	10.00	5,165	-	6,116	83,233
Unused	-	-	-	-	-	-	-	-	-	-	-	-	-	-	-	-	-	-	-	-	-	-	-	-	-	-	-	-
					5,200.0	-	5,200.0	4.00	4.00	6,688.0	-	6,688.0			197,632	-	8,928	13,920	4,768	20,064	57,600	302,912			22,525	-	25,748	351,184
<b>OPTION C</b>																												
<b>WWTP - AD &amp; COMPOSTING</b>																												
Supervisor	40.0	-	40.0	1.00	2,080.0	-	2,080.0	1.00	1.00	1,920.0	-	1,920.0	40.00	60.00	76,800	-	2,880	4,800	1,600	5,760	14,400	106,240	861	10.00	8,608	-	9,030	123,878
AD Operator Maintenance	40.0	-	40.0	1.00	2,080.0	-	2,080.0	1.00	1.00	1,920.0	-	1,920.0	30.00	45.00	57,600	-	2,160	3,600	1,200	5,760	14,400	84,720	646	10.00	6,456	-	7,201	98,377
AD Loader	40.0	-	40.0	1.00	2,080.0	-	2,080.0	1.00	1.00	1,968.0	-	1,968.0	30.00	45.00	59,040	-	2,160	2,400	960	5,904	14,400	84,864	646	10.00	6,456	-	7,213	98,533
Equipment Operators	40.0	-	40.0	1.00	2,080.0	-	2,080.0	2.00	2.00	3,936.0	-	3,936.0	30.00	45.00	118,080	-	4,320	4,800	1,920	11,808	28,800	169,728	1,291	10.00	12,912	-	14,427	197,067
Laborer	40.0	-	40.0	1.00	2,080.0	-	2,080.0	2.00	2.00	3,936.0	-	3,936.0	24.00	36.00	94,464	-	3,456	3,840	1,536	11,808	28,800	143,904	1,033	10.00	10,330	-	12,232	166,465
Unused	-	-	-	-	-	-	-	-	-	-	-	-	-	-	-	-	-	-	-	-	-	-	-	-	-	-	-	-
					10,400.0	-	10,400.0	7.00	7.00	13,680.0	-	13,680.0			405,984	-	14,976	19,440	7,216	41,040	100,800	589,456			44,762	-	50,104	684,321
<b>OPTION D</b>																												
<b>WWTP - AD &amp; COMPOSTING</b>																												
Supervisor	40.0	-	40.0	1.00	2,080.0	-	2,080.0	1.00	1.00	1,920.0	-	1,920.0	40.00	60.00	76,800	-	2,880	4,800	1,600	5,760	14,400	106,240	861	10.00	8,608	-	9,030	123,878
AD Electrician	40.0	-	40.0	1.00	2,080.0	-	2,080.0	1.00	1.00	1,920.0	-	1,920.0	30.00	45.00	57,600	-	2,160	3,600	1,200	5,760	14,400	84,720	646	10.00	6,456	-	7,201	98,377
Mechanic	40.0	-	40.0	1.00	2,080.0	-	2,080.0	1.00	1.00	1,968.0	-	1,968.0	30.00	45.00	59,040	-	2,160	2,400	960	5,904	14,400	84,864	646	10.00	6,456	-	7,213	98,533
Plumber	40.0	-	40.0	1.00	2,080.0	-	2,080.0	1.00	1.00	1,968.0	-	1,968.0	30.00	45.00	59,040	-	2,160	2,400	960	5,904	14,400	84,864	646	10.00	6,456	-	7,213	98,533
Equipment Operators	40.0	-	40.0	1.00	2,080.0	-	2,080.0	2.00	2.00	3,936.0	-	3,936.0	30.00	45.00	118,080	-	4,320	4,800	1,920	11,808	28,800	169,728	1,291	10.00	12,912	-	14,427	197,067
Laborer	40.0	-	40.0	1.00	2,080.0	-	2,080.0	1.00	1.00	1,968.0	-	1,968.0	24.00	36.00	47,232	-	1,728	1,920	768	5,904	14,400	71,952	516	10.00	5,165	-	6,116	83,233
Unused	-	-	-	-	-	-	-	-	-	-	-	-	-	-	-	-	-	-	-	-	-	-	-	-	-	-	-	-
					12,480.0	-	12,480.0	7.00	7.00	13,680.0	-	13,680.0			417,792	-	15,408	19,920	7,408	41,040	100,800	602,368			46,053	-	51,201	699,622
<b>OPTION E</b>																												
<b>UC DAVIS - COMPOSTING</b>																												
<b>Covered Static Pile</b>																												
Supervisor/GM	20.0	-	20.0	1.00	1,040.0	-	1,040.0	1.00	1.00	880.0	-	880.0	40.00	60.00	35,200	-	2,880	4,800	1,600	2,640	14,400	61,520	445	10.00	4,448	-	5,229	71,197
Equipment Operators	40.0	-	40.0	1.00	2,080.0	-	2,080.0	2.00	2.00	3,840.0	-	3,840.0	30.00	45.00	115,200	-	4,320	7,200	2,400	11,520	28,800	169,440	1,291	10.00	12,912	-	14,402	196,754
Laborer	40.0	-	40.0	1.00	2,080.0	-	2,080.0	2.00	2.00	3,936.0	-	3,936.0	24.00	36.00	94,464	-	3,456	3,840	1,536	11,808	28,800	143,904	1,033	10.00	10,330	-	12,232	166,465
Unused	-	-	-	-	-	-	-	-	-	-	-	-	-	-	-	-	-	-	-	-	-	-	-	-	-	-	-	-
					5,200.0	-	5,200.0	5.00	5.00	8,656.0	-	8,656.0			244,864	-	10,656	15,840	5,536	25,968	72,000	374,864			27,690	-	31,863	434,417
<b>OPTION F</b>																												
<b>UC DAVIS - COMPOSTING</b>																												
<b>CASP</b>																												
Supervisor/GM	20.0	-	20.0	1.00	1,040.0	-	1,040.0	1.00	1.00	880.0	-	880.0	40.00	60.00	35,200	-	2,880	4,800	1,600	2,640	14,400	61,520	445	10.00	4,448	-	5,229	71,197
Equipment Operators	40.0	-	40.0	1.00	2,080.0	-	2,080.0	2.00	2.00	3,840.0	-	3,840.0	30.00	45.00	115,200	-	4,320	7,200	2,400	11,520	28,800	169,440	1,291	10.00	12,912	-	14,402	196,754
Laborer	40.0	-	40.0	1.00	2,080.0	-	2,080.0	1.00	1.00	1,968.0	-	1,968.0	24.00	36.00	47,232	-	1,728	1,920	768	5,904	14,400	71,952	516	10.00	5,165	-	6,116	83,233
Unused	-	-	-	-	-	-	-	-	-	-	-	-	-	-	-	-	-	-	-	-	-	-	-	-	-	-	-	-
					5,200.0	-	5,200.0	4.00	4.00	6,688.0	-	6,688.0			197,632	-	8,928	13,920	4,768	20,064	57,600	302,912			22,525	-	25,748	351,184

### Annual General Admin Expenses

	<b>Option A Composting</b>	<b>Option B Composting</b>	<b>Option C AD &amp; Composting</b>	<b>Option D AD &amp; Composting</b>	<b>Option E Composting</b>	<b>Option F Composting</b>
<b>Cost Category</b>	<b>Covered Static Pile</b>	<b>CASP</b>	<b>AD-D &amp; Covered Static Pile</b>	<b>AD-C &amp; CASP</b>	<b>Covered Static Pile</b>	<b>CASP</b>
Utilities	2,400	2,400	2,400	2,400	2,400	2,400
Telephone	6,000	6,000	6,000	6,000	6,000	6,000
Information Technology	18,000	18,000	18,000	18,000	18,000	18,000
Office Supplies	6,000	6,000	6,000	6,000	6,000	6,000
Facility/Landscaping	-	-	-	-	-	-
Janitorial	6,000	6,000	6,000	6,000	6,000	6,000
Operating Supplies	6,000	6,000	6,000	6,000	6,000	6,000
Personal Protection Equipment	6,000	6,000	6,000	6,000	6,000	6,000
<b>TOTAL</b>	<b>50,400</b>	<b>50,400</b>	<b>50,400</b>	<b>50,400</b>	<b>50,400</b>	<b>50,400</b>

## Equipment Operating Expenditures

						WWTP				UC DAVIS	
						OPTION A Composting	OPTION B Composting	Option C AD & Composting	Option D AD & Composting	Option E Composting	Option F Composting
Equipment	Hours per Day	Hours per Month <sup>1</sup>	\$/Hour <sup>2</sup>	Monthly Expense	Annual Expense	Covered Static Pile	CASP	AD-D & Covered Static Pile	AD-C & CASP	Covered Static Pile	CASP
Trommel	4.0	88.0	26.00	\$ 2,288	\$ 27,456	\$ 27,456	\$ 27,456	\$ 27,456	\$ 27,456	\$ 27,456	\$ 27,456
Tub Grinder	2.0	44.0	40.00	\$ 1,760	\$ 21,120	\$ 21,120	\$ 21,120	\$ 21,120	\$ 21,120	\$ 21,120	\$ 21,120
Loader	5.0	110.0	50.00	\$ 5,500	\$ 66,000	\$ 66,000	\$ 66,000	\$ 66,000	\$ 66,000	\$ 66,000	\$ 66,000
Water Truck	4.0	88.0	26.00	\$ 2,288	\$ 27,456	\$ 27,456	\$ 27,456	\$ 27,456	\$ 27,456	\$ 27,456	\$ 27,456
CASP						\$ 25,800			\$ 25,800	\$ 25,800	\$ 25,800
AD-D							\$ 75,000				
AD-C								\$ 75,000			
Gas Cleanup							\$ 50,000	\$ 150,000			
<b>Total OPEX</b>						<b>\$ 142,032</b>	<b>\$ 140,376</b>	<b>\$ 267,032</b>	<b>\$ 365,376</b>	<b>\$ 142,032</b>	<b>\$ 140,376</b>
<p>Notes</p> <p>1. Assumes 264 days per year.</p> <p>2. Includes fuel and maintenance if applicable.</p>											



## Debt Service

	WWTP OPTION A COMPOSTING		WWTP OPTION B COMPOSTING		WWTP Option C AD & Composting AD-D & Covered Static Pile		WWTP Option D AD & Composting AD-C & CASP	
	COVERED STATIC PILE		CASP		Covered Static Pile		AD-C & CASP	
<b>1 Building / Facility</b>								
Loan Amount (\$)	\$	232,000	\$	211,000	\$	232,000	\$	1,461,000
Interest Rate (%)		5.00%		5.00%		5.00%		5.00%
Term (Years)		20		20		20		20
No. Payments		240		240		240		240
Monthly Payment	\$	1,531	\$	1,393	\$	1,531	\$	9,642
Interest Expense (\$/year)	\$	11,443	\$	10,407	\$	11,443	\$	72,059
Principal Payment (\$/year)	\$	6,931	\$	6,303	\$	6,931	\$	43,645
Total Payments (\$/year)	\$	18,373	\$	16,710	\$	18,373	\$	115,703
Replacement fund	\$	-	\$	-	\$	-	\$	-
<b>2 Processing Equipment</b>								
Loan Amount (\$)	\$	450,000	\$	3,650,000	\$	6,070,000	\$	11,863,000
Interest Rate (%)		5.00%		5.00%		5.00%		5.00%
Term (Years)		10		10		10		10
No. Payments		120		120		120		120
Monthly Payment	\$	4,773	\$	38,714	\$	64,382	\$	125,826
Interest Expense (\$/year)	\$	21,692	\$	175,945	\$	292,600	\$	571,846
Principal Payment (\$/year)	\$	35,583	\$	288,622	\$	479,982	\$	938,060
Total Payments (\$/year)	\$	57,275	\$	464,567	\$	772,581	\$	1,509,906
Replacement fund	\$	45,000	\$	365,000	\$	607,000	\$	1,186,300

## Debt Service

	WWTP OPTION A COMPOSTING  COVERED STATIC PILE	WWTP OPTION B COMPOSTING  CASP	WWTP Option C AD & Composting AD-D & Covered Static Pile	WWTP Option D AD & Composting  AD-C & CASP
<b>3 Rolling Stock</b>				
Loan Amount (\$)	\$ 250,000	\$ 200,000	\$ 250,000	\$ 200,000
Interest Rate (%)	5.00%	5.00%	5.00%	5.00%
Term (Years)	7	7	7	7
No. Payments	84	84	84	84
Monthly Payment	\$ 3,533	\$ 2,827	\$ 3,533	\$ 2,827
Interest Expense (\$/year)	\$ 11,805	\$ 9,444	\$ 11,805	\$ 9,444
Principal Payment (\$/year)	\$ 30,597	\$ 24,477	\$ 30,597	\$ 24,477
Total Payments (\$/year)	\$ 42,402	\$ 33,921	\$ 42,402	\$ 33,921
Replacement fund	\$ 35,714	\$ 28,571	\$ 35,714	\$ 28,571
<b>4 Other Equipment</b>				
Loan Amount (\$)	\$ 50,000	\$ 200,000	\$ 50,000	\$ 200,000
Interest Rate (%)	5.00%	5.00%	5.00%	5.00%
Term (Years)	7	7	7	7
No. Payments	84	84	84	84
Monthly Payment	\$ 707	\$ 2,827	\$ 707	\$ 2,827
Interest Expense (\$/year)	\$ 2,361	\$ 9,444	\$ 2,361	\$ 9,444
Principal Payment (\$/year)	\$ 6,119	\$ 24,477	\$ 6,119	\$ 24,477
Total Payments (\$/year)	\$ 8,480	\$ 33,921	\$ 8,480	\$ 33,921
Replacement fund	\$ 7,143	\$ 28,571	\$ 7,143	\$ 28,571
<b>5 TOTAL</b>				
Loan Amount (\$)	\$ 982,000	\$ 4,261,000	\$ 6,602,000	\$ 13,724,000
Monthly Payment	\$ 10,544	\$ 45,760	\$ 70,153	\$ 141,121
Interest Expense (\$/year)	\$ 47,301	\$ 205,240	\$ 318,208	\$ 662,794
Principal Payment (\$/year)	\$ 79,230	\$ 343,879	\$ 523,628	\$ 1,030,659
Total Payments (\$/year)	\$ 126,531	\$ 549,120	\$ 841,836	\$ 1,693,452
Replacement fund	\$ 87,857	\$ 422,143	\$ 649,857	\$ 1,243,443

## Capital Expenditures

WWTP											
OPTION A - COMPOSTING COVERED STATIC PILE				OPTION B - COMPOSTING CASP				Option C - AD & Composting AD-D & Covered Static Pile			
Building / Facility	Qty	Price	Total	Building / Facility	Qty	Price	Total	Building / Facility	Qty	Price	Total
Site Preparation	1.0	200,000	200,000	Site Preparation	1.0	200,000	200,000	Site Preparation	1.0	200,000	200,000
Storm Water	15.0	2,133	32,000	Storm Water	5.0	2,200	11,000	Storm Water	15.0	2,133	32,000
Unused			-	Unused			-	Unused			-
<b>Subtotal</b>			<b>232,000</b>	<b>Subtotal</b>			<b>211,000</b>	<b>Subtotal</b>			<b>232,000</b>
<b>Processing Equip</b>				<b>Processing Equip</b>				<b>Processing Equip</b>			
Trommel	1.0	200,000	200,000	Trommel	1.0	200,000	200,000	Trommel	1.0	200,000	200,000
Tub Grinder	1.0	250,000	250,000	Tub Grinder	1.0	250,000	250,000	Tub Grinder	1.0	250,000	250,000
Unused			-	CASP System	1.0	1,400,000	1,400,000	AD-D	1.0	2,000,000	2,000,000
Unused			-	CASP Construction	1.0	1,800,000	1,800,000	Construction	1.0	3,270,000	3,270,000
Unused			-	Unused			-	Gas Clean up (CoGen)	1.0	250,000	250,000
Unused			-				-	Pipeline and Connect to WWTP	1.0	100,000	100,000
Unused			-				-				
Unused			-				-				
Unused			-				-				
<b>Total Equip</b>			<b>450,000</b>	<b>Total Equip</b>			<b>3,650,000</b>	<b>Total Equip</b>			<b>6,070,000</b>
<b>Rolling Stock</b>				<b>Rolling Stock</b>				<b>Rolling Stock</b>			
Loader	1.0	200,000	200,000	Loader	1.0	200,000	200,000	Loader	1.0	200,000	200,000
Water Truck	1.0	50,000	50,000	Unused			-	Water Truck	1.0	50,000	50,000
Unused			-	Unused			-	Unused			-
Unused			-	Unused			-	Unused			-
<b>Total Rolling Stock</b>			<b>250,000</b>	<b>Total Rolling Stock</b>			<b>200,000</b>	<b>Total Rolling Stock</b>			<b>250,000</b>
<b>Other Equipment</b>				<b>Other Equipment</b>				<b>Other Equipment</b>			
Scale	1.0	50,000	50,000	Scale	1.0	50,000	50,000	Scale	1.0	50,000	50,000
Unused			-	Cover Winder Machine	1.0	150,000	150,000	Unused			-
<b>Total Other equip</b>			<b>50,000</b>	<b>Total Other equip</b>			<b>200,000</b>	<b>Total Other equip</b>			<b>50,000</b>
<b>TOTAL</b>			<b>982,000</b>	<b>TOTAL</b>			<b>4,261,000</b>	<b>TOTAL</b>			<b>6,602,000</b>

## Capital Expenditures

WWTP				UC DAVIS							
Option D - AD & Composting AD-C & CASP				OPTION E - COMPOSTING COVERED STATIC PILE				OPTION F - COMPOSTING CASP			
Building / Facility	Qty	Price	Total	Building / Facility	Qty	Price	Total	Building / Facility	Qty	Price	Total
Site Preparation	1.0	200,000	200,000	Site Preparation	1.0	200,000.00	200,000	Site Preparation	1.0	200,000.00	200,000
Storm Water	5.0	2,200	11,000	Storm Water	15.0	2,133	32,000	Storm Water	5.0	2,200	11,000
Receiving Building	1.0	1,250,000	1,250,000	Unused			-	Unused			-
<b>Subtotal</b>			<b>1,461,000</b>	<b>Subtotal</b>			<b>232,000</b>	<b>Subtotal</b>			<b>211,000</b>
<b>Processing Equip</b>				<b>Processing Equip</b>				<b>Processing Equip</b>			
Trommel	1.0	200,000	200,000	Trommel	1.0	200,000	200,000	Trommel	1.0	200,000	200,000
Tub Grinder	1.0	250,000	250,000	Tub Grinder	1.0	250,000	250,000	Tub Grinder	1.0	250,000	250,000
CASP System	1.0	1,400,000	1,400,000	Unused			-	CASP System	1.0	1,400,000	1,400,000
CASP Construction	1.0	1,800,000	1,800,000	Unused			-	CASP Construction	1.0	1,800,000	1,800,000
Gas Clean up (CNG)	1.0	3,113,000	3,113,000	Unused			-	Unused			-
Pipeline and Connect to											
WWTP	1.0	100,000	100,000	Unused			-	Unused			-
AD-C	1.0	2,500,000	2,500,000	Unused			-	Unused			-
Construction	1.0	2,500,000	2,500,000	Unused			-	Unused			-
<b>Total Equip</b>			<b>11,863,000</b>	<b>Total Equip</b>			<b>450,000</b>	<b>Total Equip</b>			<b>3,650,000</b>
<b>Rolling Stock</b>				<b>Rolling Stock</b>				<b>Rolling Stock</b>			
Loader	1.0	200,000	200,000	Loader	1.0	200,000	200,000	Loader	1.0	200,000	200,000
Unused			-	Water Truck	1.0	50,000	50,000	Unused			-
Unused			-	Unused			-	Unused			-
Unused			-	Unused			-	Unused			-
<b>Total Rolling Stock</b>			<b>200,000</b>	<b>Total Rolling Stock</b>			<b>250,000</b>	<b>Total Rolling Stock</b>			<b>200,000</b>
<b>Other Equipment</b>				<b>Other Equipment</b>				<b>Other Equipment</b>			
Scale	1.0	50,000	50,000	Scale	1.0	50,000	50,000	Scale	1.0	50,000	50,000
Cover Winder Machine	1.0	150,000	150,000	Unused			-	Cover Winder Machine	1.0	150,000	150,000
<b>Total Other equip</b>			<b>200,000</b>	<b>Total Other equip</b>			<b>50,000</b>	<b>Total Other equip</b>			<b>200,000</b>
<b>TOTAL</b>			<b>13,724,000</b>	<b>TOTAL</b>			<b>982,000</b>	<b>TOTAL</b>			<b>4,261,000</b>

# **APPENDIX F**

## **Additional Financial Pro Forma Scenarios**

**Financial Pro Forma**  
**for**  
**Project with City and UC Davis feedstock**  
**with the removal of recovered C&D**  
**materials as potential City-generated**  
**feedstock**

Basic Assumptions						
	SITE WWTP				SITE UC DAVIS	
	Option A Composting	Option B Composting	Option C AD & Composting AD-D &	Option D AD & Composting	Option E Composting	Option F Composting
	Covered Static Pile	CASP	Covered Static Pile	AD-C & CASP	Covered Static Pile	CASP
<b>Incoming Tons</b>						
TPD	95.0	95.0	95.0	95.0	95.0	95.0
TPY	25,074.7	25,074.7	25,074.7	25,074.7	25,074.7	25,074.7
<b>Commodity Sales</b>						
Compost TPY	16,716.6	16,716.6	14,432.1	14,432.1	16,716.6	16,716.6
Electricity kWh			1,301,789			
CNG Diesel gallon Equivalent				150,847		
<b>Personnel (FTE)</b>	4.5	3.5	7.0	7.0	4.5	3.5
<b>Equipment</b>						
Trommel	1.0	1.0	1.0	1.0	1.0	1.0
Tub Grinder	1.0	1.0	1.0	1.0	1.0	1.0
Storage Tank	1.0		1.0		1.0	
CASP		1.0				1.0
Loader	1.0	1.0	1.0	1.0	1.0	1.0
Cover Winder		1.0		1.0		
AD-D			1.0			
Gas Cleanup			1.0	1.0		
Pipeline Connection			1.0	1.0		
AD-C				1.0		
Water Truck	1.0		1.0		1.0	
<b>Facility</b>						
Site Prep & Storm Water	1.0	1.0	1.0	1.0	1.0	1.0
Building				1.0		
Scale	1.0	1.0	1.0	1.0	1.0	1.0

## Financial Proforma

	SITE - WWTP						SITE - UC DAVIS					
	Option A Composting		Option B Composting		Option C AD & Composting AD-D & Covered Static Pile		Option D AD & Composting AD-C & CASP		Option E Composting		Option F Composting	
	Covered Static Pile		CASP		Covered Static Pile		AD-C & CASP		Covered Static Pile		CASP	
	\$ Per Incoming ton      Annual		\$ Per Incoming ton      Annual		\$ Per Incoming ton      Annual		\$ Per Incoming ton      Annual		\$ Per Incoming ton      Annual		\$ Per Incoming ton      Annual	
<b>Operations Costs</b>												
Labor	\$17.32	\$434,417	\$14.01	\$351,184	\$27.29	\$684,321	\$27.90	\$699,622	\$17.32	\$434,417	\$14.01	\$351,184
Equip Maint & Ops	\$5.66	\$142,032	\$5.60	\$140,376	\$10.65	\$267,032	\$14.57	\$365,376	\$5.66	\$142,032	\$5.60	\$140,376
<b>Sub-Total</b>	<b>\$22.98</b>	<b>\$576,449</b>	<b>\$19.61</b>	<b>\$491,560</b>	<b>\$37.94</b>	<b>\$951,353</b>	<b>\$42.47</b>	<b>\$1,064,998</b>	<b>\$22.98</b>	<b>\$576,449</b>	<b>\$19.61</b>	<b>\$491,560</b>
<b>Disposal Costs <sup>1</sup></b>												
Disposal - Residual Solid Waste Recovered/Diverted w/Negative Value	\$0.00	-	\$0.00	-	\$0.00	-	\$0.00	-	\$0.00	-	\$0.00	-
<b>Sub-Total</b>	<b>\$0.00</b>	<b>\$0</b>	<b>\$0.00</b>	<b>\$0</b>	<b>\$0.00</b>	<b>\$0</b>	<b>\$0.00</b>	<b>\$0</b>	<b>\$0.00</b>	<b>\$0</b>	<b>\$0.00</b>	<b>\$0</b>
<b>General &amp; Administrative Costs <sup>2</sup></b>												
Personnel <sup>3</sup>												
Facility G&A	\$2.01	\$50,400	\$2.01	\$50,400	\$2.01	\$50,400	\$2.01	\$50,400	\$2.01	\$50,400	\$2.01	\$50,400
<b>Sub-Total</b>	<b>\$2.01</b>	<b>\$50,400</b>	<b>\$2.01</b>	<b>\$50,400</b>	<b>\$2.01</b>	<b>\$50,400</b>	<b>\$2.01</b>	<b>\$50,400</b>	<b>\$2.01</b>	<b>\$50,400</b>	<b>\$2.01</b>	<b>\$50,400</b>
<b>Debt Service &amp; Equipment Replacement</b>												
Debt Service <sup>4</sup>	\$5.05	126,531	\$21.90	549,120	\$33.57	841,836	\$67.54	1,693,452	\$5.05	126,531	\$21.90	549,120
Equipment Replacement	\$3.50	\$87,857	\$16.84	\$422,143	\$25.92	\$649,857	\$49.59	\$1,243,443	\$3.50	\$87,857	\$16.84	\$422,143
<b>Sub-Total</b>	<b>\$8.55</b>	<b>\$214,388</b>	<b>\$38.74</b>	<b>\$971,263</b>	<b>\$59.49</b>	<b>\$1,491,694</b>	<b>\$117.13</b>	<b>\$2,936,895</b>	<b>\$8.55</b>	<b>\$214,388</b>	<b>\$38.74</b>	<b>\$971,263</b>
<b>Total Costs</b>	<b>\$33.55</b>	<b>\$841,237</b>	<b>\$60.35</b>	<b>\$1,513,223</b>	<b>\$99.44</b>	<b>\$2,493,447</b>	<b>\$161.61</b>	<b>\$4,052,293</b>	<b>\$33.55</b>	<b>\$841,237</b>	<b>\$60.35</b>	<b>\$1,513,223</b>
<b>Revenue from Commodity Sales</b>	\$13.33	\$334,331	\$13.33	\$334,331	\$20.13	\$504,738	\$35.76	\$896,554	\$13.33	\$334,331	\$13.33	\$334,331
<b>Net Cost</b>	<b>\$20.22</b>	<b>\$506,906</b>	<b>\$47.02</b>	<b>\$1,178,892</b>	<b>\$79.31</b>	<b>\$1,988,708</b>	<b>\$125.85</b>	<b>\$3,155,740</b>	<b>\$20.22</b>	<b>\$506,906</b>	<b>\$47.02</b>	<b>\$1,178,892</b>
<b>Incoming Tons</b>	25,075		25,075		25,075		25,075		25,075		25,075	

**Notes**

1. Assumes no disposal costs.
2. General and administrative costs are expenses required to administer a business, and which are not related to the construction, production or sale of goods or services.
3. No General & Administrative staff is included in this Pro-Forma.
4. This represents principal and interest.



### Incoming Tonnage & Products Generated

				Option A Composting	Option B Composting	Option C AD & Composting			Option D AD & Composting			Option E Composting	Option F Composting
				Covered Static Pile	CASP	AD-D & Covered Static Pile			AD-C & CASP			Covered Static Pile	CASP
City of Davis	TPD	TPY	%	Compost	Compost	Compost	Electricity	Total	Compost	CNG	Total	Compost	Compost
Mixed GW & FW	26.00	6,864.0	55.9%										
GW Loose	18.0	4,752.0	38.7%										
Other Organics	2.5	654.7	5.3%										
<b>Total</b>	<b>46.5</b>	<b>12,270.7</b>	<b>100.0%</b>										
<b>UC Davis</b>													
Postconsumer FW	0.50	132.0	1.0%										
Digestate	2.0	528.0	4.1%										
Animal Bedding	41.0	10,824.0	84.5%										
GW	5.0	1,320.0	10.3%										
<b>Total</b>	<b>48.5</b>	<b>12,804.0</b>	<b>100.0%</b>										
<b>GRAND TOTAL</b>	<b>95.0</b>	<b>25,074.7</b>											
Compost Product Tons				16,717	16,717	14,432			14,432			16,717	16,717
Biogas to Electricity Product (kWh)							1,301,789						
Biogas to Fuel Product (Diesel Gallon Equivalent)									150,847				
<b>Revenue per Unit</b>				\$20.00	\$20.00	\$20.00	\$0.166		\$20.00	\$4.03		\$20.00	\$20.00
<b>Commodity Sales Revenue</b>				<b>\$334,331</b>	<b>\$334,331</b>	\$288,641	\$216,097	<b>\$504,738</b>	\$288,641	\$607,912	<b>\$896,554</b>	<b>\$334,331</b>	<b>\$334,331</b>

<b>Incoming Tons</b>	<b>25,074.7</b>	<b>25,074.7</b>	<b>25,074.7</b>		<b>25,074.7</b>				<b>25,074.7</b>			<b>25,074.7</b>	<b>25,074.7</b>
% Tons to Composting Operation	100.0%	100.0%										100.0%	100.0%
<b>Tons to Composting Operation</b>	<b>25,074.7</b>	<b>25,074.7</b>	<b>11,352.0</b>		<b>11,352.0</b>				<b>25,074.7</b>			<b>25,074.7</b>	<b>25,074.7</b>
% Compost Production	66.667%	66.667%	66.7%		66.7%				66.667%			66.667%	66.667%
Compost Product	16,716.6	16,716.6	7,568.0		7,568.0				16,716.6			16,716.6	16,716.6
<b>Tons to Digester</b>			13,728.0		13,728.0								
Tons to Composting Operation			10,296.0		10,296.0								
% Compost Production			66.7%		66.7%								
Compost Product			6,864.0		6,864.0								
<b>Total Compost Product Tons</b>	<b>16,716.6</b>	<b>16,716.6</b>	<b>14,432.1</b>		<b>14,432.1</b>				<b>16,716.6</b>			<b>16,716.6</b>	<b>16,716.6</b>

**Direct Labor**

OPTION A WWTP - COMPOSTING Covered Static Pile					Annual Hours						Annual Labor Hours			Annual Labor Compensation														
	Regular Hours	OT Hours	Total Weekly Hours	# of Shifts	Total Regular Hours	Total OT Hours	TOTAL HOURS	Crew Size	Total Crew	Total Regular Hours	Total OT Hours	TOTAL HOURS	Regular Rate	OT Rate	Regular Wages	OT Wages	Holiday Wages	Vacation Wages	Sick Leave Wages	Pension	Medical	Total Compensation	WC Factor	WC Rate	WC Expense	Unifor m	Payroll Tax	Wages Expense
Supervisor/GM	20.0	-	20.0	1.00	1,040.0	-	1,040.0	1.00	1.00	880.0	-	880.0	40.00	60.00	35,200	-	2,880	4,800	1,600	2,640	14,400	61,520	445	10.00	4,448	-	5,229	71,197
Equipment Operators	40.0	-	40.0	1.00	2,080.0	-	2,080.0	2.00	2.00	3,840.0	-	3,840.0	30.00	45.00	115,200	-	4,320	7,200	2,400	11,520	28,800	169,440	1,291	10.00	12,912	-	14,402	196,754
Laborer	40.0	-	40.0	1.00	2,080.0	-	2,080.0	2.00	2.00	3,936.0	-	3,936.0	24.00	36.00	94,464	-	3,456	3,840	1,536	11,808	28,800	143,904	1,033	10.00	10,330	-	12,232	166,465
Unused	-	-	-	-	-	-	-	-	-	-	-	-	-	-	-	-	-	-	-	-	-	-	-	-	-	-	-	-
					5,200.0	-	5,200.0	5.00	5.00	8,656.0	-	8,656.0			244,864	-	10,656	15,840	5,536	25,968	72,000	374,864			27,690	-	31,863	434,417
<b>OPTION B</b>																												
<b>WWTP - COMPOSTING CASP</b>																												
Supervisor/GM	20.0	-	20.0	1.00	1,040.0	-	1,040.0	1.00	1.00	880.0	-	880.0	40.00	60.00	35,200	-	2,880	4,800	1,600	2,640	14,400	61,520	445	10.00	4,448	-	5,229	71,197
Equipment Operators	40.0	-	40.0	1.00	2,080.0	-	2,080.0	2.00	2.00	3,840.0	-	3,840.0	30.00	45.00	115,200	-	4,320	7,200	2,400	11,520	28,800	169,440	1,291	10.00	12,912	-	14,402	196,754
Laborer	40.0	-	40.0	1.00	2,080.0	-	2,080.0	1.00	1.00	1,968.0	-	1,968.0	24.00	36.00	47,232	-	1,728	1,920	768	5,904	14,400	71,952	516	10.00	5,165	-	6,116	83,233
Unused	-	-	-	-	-	-	-	-	-	-	-	-	-	-	-	-	-	-	-	-	-	-	-	-	-	-	-	-
					5,200.0	-	5,200.0	4.00	4.00	6,688.0	-	6,688.0			197,632	-	8,928	13,920	4,768	20,064	57,600	302,912			22,525	-	25,748	351,184
<b>OPTION C</b>																												
<b>WWTP - AD &amp; COMPOSTING</b>																												
Supervisor	40.0	-	40.0	1.00	2,080.0	-	2,080.0	1.00	1.00	1,920.0	-	1,920.0	40.00	60.00	76,800	-	2,880	4,800	1,600	5,760	14,400	106,240	861	10.00	8,608	-	9,030	123,878
AD Operator Maintenance	40.0	-	40.0	1.00	2,080.0	-	2,080.0	1.00	1.00	1,920.0	-	1,920.0	30.00	45.00	57,600	-	2,160	3,600	1,200	5,760	14,400	84,720	646	10.00	6,456	-	7,201	98,377
AD Loader	40.0	-	40.0	1.00	2,080.0	-	2,080.0	1.00	1.00	1,968.0	-	1,968.0	30.00	45.00	59,040	-	2,160	2,400	960	5,904	14,400	84,864	646	10.00	6,456	-	7,213	98,533
Equipment Operators	40.0	-	40.0	1.00	2,080.0	-	2,080.0	2.00	2.00	3,936.0	-	3,936.0	30.00	45.00	118,080	-	4,320	4,800	1,920	11,808	28,800	169,728	1,291	10.00	12,912	-	14,427	197,067
Laborer	40.0	-	40.0	1.00	2,080.0	-	2,080.0	2.00	2.00	3,936.0	-	3,936.0	24.00	36.00	94,464	-	3,456	3,840	1,536	11,808	28,800	143,904	1,033	10.00	10,330	-	12,232	166,465
Unused	-	-	-	-	-	-	-	-	-	-	-	-	-	-	-	-	-	-	-	-	-	-	-	-	-	-	-	-
					10,400.0	-	10,400.0	7.00	7.00	13,680.0	-	13,680.0			405,984	-	14,976	19,440	7,216	41,040	100,800	589,456			44,762	-	50,104	684,321
<b>OPTION D</b>																												
<b>WWTP - AD &amp; COMPOSTING</b>																												
Supervisor	40.0	-	40.0	1.00	2,080.0	-	2,080.0	1.00	1.00	1,920.0	-	1,920.0	40.00	60.00	76,800	-	2,880	4,800	1,600	5,760	14,400	106,240	861	10.00	8,608	-	9,030	123,878
AD Electrician	40.0	-	40.0	1.00	2,080.0	-	2,080.0	1.00	1.00	1,920.0	-	1,920.0	30.00	45.00	57,600	-	2,160	3,600	1,200	5,760	14,400	84,720	646	10.00	6,456	-	7,201	98,377
Mechanic	40.0	-	40.0	1.00	2,080.0	-	2,080.0	1.00	1.00	1,968.0	-	1,968.0	30.00	45.00	59,040	-	2,160	2,400	960	5,904	14,400	84,864	646	10.00	6,456	-	7,213	98,533
Plumber	40.0	-	40.0	1.00	2,080.0	-	2,080.0	1.00	1.00	1,968.0	-	1,968.0	30.00	45.00	59,040	-	2,160	2,400	960	5,904	14,400	84,864	646	10.00	6,456	-	7,213	98,533
Equipment Operators	40.0	-	40.0	1.00	2,080.0	-	2,080.0	2.00	2.00	3,936.0	-	3,936.0	30.00	45.00	118,080	-	4,320	4,800	1,920	11,808	28,800	169,728	1,291	10.00	12,912	-	14,427	197,067
Laborer	40.0	-	40.0	1.00	2,080.0	-	2,080.0	1.00	1.00	1,968.0	-	1,968.0	24.00	36.00	47,232	-	1,728	1,920	768	5,904	14,400	71,952	516	10.00	5,165	-	6,116	83,233
Unused	-	-	-	-	-	-	-	-	-	-	-	-	-	-	-	-	-	-	-	-	-	-	-	-	-	-	-	-
					12,480.0	-	12,480.0	7.00	7.00	13,680.0	-	13,680.0			417,792	-	15,408	19,920	7,408	41,040	100,800	602,368			46,053	-	51,201	699,622
<b>OPTION E</b>																												
<b>UC DAVIS - COMPOSTING</b>																												
<b>Covered Static Pile</b>																												
Supervisor/GM	20.0	-	20.0	1.00	1,040.0	-	1,040.0	1.00	1.00	880.0	-	880.0	40.00	60.00	35,200	-	2,880	4,800	1,600	2,640	14,400	61,520	445	10.00	4,448	-	5,229	71,197
Equipment Operators	40.0	-	40.0	1.00	2,080.0	-	2,080.0	2.00	2.00	3,840.0	-	3,840.0	30.00	45.00	115,200	-	4,320	7,200	2,400	11,520	28,800	169,440	1,291	10.00	12,912	-	14,402	196,754
Laborer	40.0	-	40.0	1.00	2,080.0	-	2,080.0	2.00	2.00	3,936.0	-	3,936.0	24.00	36.00	94,464	-	3,456	3,840	1,536	11,808	28,800	143,904	1,033	10.00	10,330	-	12,232	166,465
Unused	-	-	-	-	-	-	-	-	-	-	-	-	-	-	-	-	-	-	-	-	-	-	-	-	-	-	-	-
					5,200.0	-	5,200.0	5.00	5.00	8,656.0	-	8,656.0			244,864	-	10,656	15,840	5,536	25,968	72,000	374,864			27,690	-	31,863	434,417
<b>OPTION F</b>																												
<b>UC DAVIS - COMPOSTING</b>																												
<b>CASP</b>																												
Supervisor/GM	20.0	-	20.0	1.00	1,040.0	-	1,040.0	1.00	1.00	880.0	-	880.0	40.00	60.00	35,200	-	2,880	4,800	1,600	2,640	14,400	61,520	445	10.00	4,448	-	5,229	71,197
Equipment Operators	40.0	-	40.0	1.00	2,080.0	-	2,080.0	2.00	2.00	3,840.0	-	3,840.0	30.00	45.00	115,200	-	4,320	7,200	2,400	11,520	28,800	169,440	1,291	10.00	12,912	-	14,402	196,754
Laborer	40.0	-	40.0	1.00	2,080.0	-	2,080.0	1.00	1.00	1,968.0	-	1,968.0	24.00	36.00	47,232	-	1,728	1,920	768	5,904	14,400	71,952	516	10.00	5,165	-	6,116	83,233
Unused	-	-	-	-	-	-	-	-	-	-	-	-	-	-	-	-	-	-	-	-	-	-	-	-	-	-	-	-
					5,200.0	-	5,200.0	4.00	4.00	6,688.0	-	6,688.0			197,632	-	8,928	13,920	4,768	20,064	57,600	302,912			22,525	-	25,748	351,184

### Annual General Admin Expenses

	Option A Composting	Option B Composting	Option C AD & Composting	Option D AD & Composting	Option E Composting	Option F Composting
Cost Category	Covered Static Pile	CASP	AD-D & Covered Static Pile	AD-C & CASP	Covered Static Pile	CASP
Utilities	2,400	2,400	2,400	2,400	2,400	2,400
Telephone	6,000	6,000	6,000	6,000	6,000	6,000
Information Technology	18,000	18,000	18,000	18,000	18,000	18,000
Office Supplies	6,000	6,000	6,000	6,000	6,000	6,000
Facility/Landscaping	-	-	-	-	-	-
Janitorial	6,000	6,000	6,000	6,000	6,000	6,000
Operating Supplies	6,000	6,000	6,000	6,000	6,000	6,000
Personal Protection Equipment	6,000	6,000	6,000	6,000	6,000	6,000
<b>TOTAL</b>	<b>50,400</b>	<b>50,400</b>	<b>50,400</b>	<b>50,400</b>	<b>50,400</b>	<b>50,400</b>

### Equipment Operating Expenditures

						WWTP				UC DAVIS	
						OPTION A Composting	OPTION B Composting	Option C AD & Composting	Option D AD & Composting	Option E Composting	Option F Composting
Equipment	Hours per Day	Hours per Month <sup>1</sup>	\$/Hour <sup>2</sup>	Monthly Expense	Annual Expense	Covered Static Pile	CASP	AD-D & Covered Static Pile	AD-C & CASP	Covered Static Pile	CASP
Trommel	4.0	88.0	26.00	\$ 2,288	\$ 27,456	\$ 27,456	\$ 27,456	\$ 27,456	\$ 27,456	\$ 27,456	\$ 27,456
Tub Grinder	2.0	44.0	40.00	\$ 1,760	\$ 21,120	\$ 21,120	\$ 21,120	\$ 21,120	\$ 21,120	\$ 21,120	\$ 21,120
Loader	5.0	110.0	50.00	\$ 5,500	\$ 66,000	\$ 66,000	\$ 66,000	\$ 66,000	\$ 66,000	\$ 66,000	\$ 66,000
Water Truck	4.0	88.0	26.00	\$ 2,288	\$ 27,456	\$ 27,456	\$ 27,456	\$ 27,456	\$ 27,456	\$ 27,456	\$ 27,456
CASP						\$ 25,800			\$ 25,800		\$ 25,800
AD-D							\$ 75,000				
AD-C									\$ 75,000		
Gas Cleanup							\$ 50,000		\$ 150,000		
<b>Total OPEX</b>						<b>\$ 142,032</b>	<b>\$ 140,376</b>	<b>\$ 267,032</b>	<b>\$ 365,376</b>	<b>\$ 142,032</b>	<b>\$ 140,376</b>
<p>Notes</p> <p>1. Assumes 264 days per year.</p> <p>2. Includes fuel and maintenance if applicable.</p>											

## Debt Service

	WWTP OPTION A COMPOSTING		WWTP OPTION B COMPOSTING		WWTP Option C AD & Composting AD-D & Covered Static Pile		WWTP Option D AD & Composting AD-C & CASP	
	COVERED STATIC PILE		CASP					
<b>1 Building / Facility</b>								
Loan Amount (\$)	\$	232,000	\$	211,000	\$	232,000	\$	1,461,000
Interest Rate (%)		5.00%		5.00%		5.00%		5.00%
Term (Years)		20		20		20		20
No. Payments		240		240		240		240
Monthly Payment	\$	1,531	\$	1,393	\$	1,531	\$	9,642
Interest Expense (\$/year)	\$	11,443	\$	10,407	\$	11,443	\$	72,059
Principal Payment (\$/year)	\$	6,931	\$	6,303	\$	6,931	\$	43,645
Total Payments (\$/year)	\$	18,373	\$	16,710	\$	18,373	\$	115,703
Replacement fund	\$	-	\$	-	\$	-	\$	-
<b>2 Processing Equipment</b>								
Loan Amount (\$)	\$	450,000	\$	3,650,000	\$	6,070,000	\$	11,863,000
Interest Rate (%)		5.00%		5.00%		5.00%		5.00%
Term (Years)		10		10		10		10
No. Payments		120		120		120		120
Monthly Payment	\$	4,773	\$	38,714	\$	64,382	\$	125,826
Interest Expense (\$/year)	\$	21,692	\$	175,945	\$	292,600	\$	571,846
Principal Payment (\$/year)	\$	35,583	\$	288,622	\$	479,982	\$	938,060
Total Payments (\$/year)	\$	57,275	\$	464,567	\$	772,581	\$	1,509,906
Replacement fund	\$	45,000	\$	365,000	\$	607,000	\$	1,186,300

## Debt Service

	WWTP OPTION A COMPOSTING		WWTP OPTION B COMPOSTING		WWTP Option C AD & Composting AD-D & Covered Static Pile		WWTP Option D AD & Composting AD-C & CASP	
	COVERED STATIC PILE		CASP		Covered Static Pile		AD-C & CASP	
<b>3 Rolling Stock</b>								
Loan Amount (\$)	\$	250,000	\$	200,000	\$	250,000	\$	200,000
Interest Rate (%)		5.00%		5.00%		5.00%		5.00%
Term (Years)		7		7		7		7
No. Payments		84		84		84		84
Monthly Payment	\$	3,533	\$	2,827	\$	3,533	\$	2,827
Interest Expense (\$/year)	\$	11,805	\$	9,444	\$	11,805	\$	9,444
Principal Payment (\$/year)	\$	30,597	\$	24,477	\$	30,597	\$	24,477
Total Payments (\$/year)	\$	42,402	\$	33,921	\$	42,402	\$	33,921
Replacement fund	\$	35,714	\$	28,571	\$	35,714	\$	28,571
<b>4 Other Equipment</b>								
Loan Amount (\$)	\$	50,000	\$	200,000	\$	50,000	\$	200,000
Interest Rate (%)		5.00%		5.00%		5.00%		5.00%
Term (Years)		7		7		7		7
No. Payments		84		84		84		84
Monthly Payment	\$	707	\$	2,827	\$	707	\$	2,827
Interest Expense (\$/year)	\$	2,361	\$	9,444	\$	2,361	\$	9,444
Principal Payment (\$/year)	\$	6,119	\$	24,477	\$	6,119	\$	24,477
Total Payments (\$/year)	\$	8,480	\$	33,921	\$	8,480	\$	33,921
Replacement fund	\$	7,143	\$	28,571	\$	7,143	\$	28,571
<b>5 TOTAL</b>								
Loan Amount (\$)	\$	982,000	\$	4,261,000	\$	6,602,000	\$	13,724,000
Monthly Payment	\$	10,544	\$	45,760	\$	70,153	\$	141,121
Interest Expense (\$/year)	\$	47,301	\$	205,240	\$	318,208	\$	662,794
Principal Payment (\$/year)	\$	79,230	\$	343,879	\$	523,628	\$	1,030,659
Total Payments (\$/year)	\$	126,531	\$	549,120	\$	841,836	\$	1,693,452
Replacement fund	\$	87,857	\$	422,143	\$	649,857	\$	1,243,443

## Capital Expenditures

WWTP											
OPTION A - COMPOSTING COVERED STATIC PILE				OPTION B - COMPOSTING CASP				Option C - AD & Composting AD-D & Covered Static Pile			
Building / Facility	Qty	Price	Total	Building / Facility	Qty	Price	Total	Building / Facility	Qty	Price	Total
Site Preparation	1.0	200,000	200,000	Site Preparation	1.0	200,000	200,000	Site Preparation	1.0	200,000	200,000
Storm Water	15.0	2,133	32,000	Storm Water	5.0	2,200	11,000	Storm Water	15.0	2,133	32,000
Unused			-	Unused			-	Unused			-
<b>Subtotal</b>			<b>232,000</b>	<b>Subtotal</b>			<b>211,000</b>	<b>Subtotal</b>			<b>232,000</b>
<b>Processing Equip</b>				<b>Processing Equip</b>				<b>Processing Equip</b>			
Trommel	1.0	200,000	200,000	Trommel	1.0	200,000	200,000	Trommel	1.0	200,000	200,000
Tub Grinder	1.0	250,000	250,000	Tub Grinder	1.0	250,000	250,000	Tub Grinder	1.0	250,000	250,000
Unused			-	CASP System	1.0	1,400,000	1,400,000	AD-D	1.0	2,000,000	2,000,000
Unused			-	CASP Construction	1.0	1,800,000	1,800,000	Construction	1.0	3,270,000	3,270,000
Unused			-	Unused			-	Gas Clean up (CoGen)	1.0	250,000	250,000
Unused			-				-	Pipeline and Connect to WWTP	1.0	100,000	100,000
Unused			-				-				
Unused			-				-				
Unused			-				-				
<b>Total Equip</b>			<b>450,000</b>	<b>Total Equip</b>			<b>3,650,000</b>	<b>Total Equip</b>			<b>6,070,000</b>
<b>Rolling Stock</b>				<b>Rolling Stock</b>				<b>Rolling Stock</b>			
Loader	1.0	200,000	200,000	Loader	1.0	200,000	200,000	Loader	1.0	200,000	200,000
Water Truck	1.0	50,000	50,000	Unused			-	Water Truck	1.0	50,000	50,000
Unused			-	Unused			-	Unused			-
Unused			-	Unused			-	Unused			-
<b>Total Rolling Stock</b>			<b>250,000</b>	<b>Total Rolling Stock</b>			<b>200,000</b>	<b>Total Rolling Stock</b>			<b>250,000</b>
<b>Other Equipment</b>				<b>Other Equipment</b>				<b>Other Equipment</b>			
Scale	1.0	50,000	50,000	Scale	1.0	50,000	50,000	Scale	1.0	50,000	50,000
Unused			-	Cover Winder Machine	1.0	150,000	150,000	Unused			-
<b>Total Other equip</b>			<b>50,000</b>	<b>Total Other equip</b>			<b>200,000</b>	<b>Total Other equip</b>			<b>50,000</b>
<b>TOTAL</b>			<b>982,000</b>	<b>TOTAL</b>			<b>4,261,000</b>	<b>TOTAL</b>			<b>6,602,000</b>

## Capital Expenditures

WWTP				UC DAVIS							
Option D - AD & Composting AD-C & CASP				OPTION E - COMPOSTING COVERED STATIC PILE				OPTION F - COMPOSTING CASP			
Building / Facility	Qty	Price	Total	Building / Facility	Qty	Price	Total	Building / Facility	Qty	Price	Total
Site Preparation	1.0	200,000	200,000	Site Preparation	1.0	200,000.00	200,000	Site Preparation	1.0	200,000.00	200,000
Storm Water	5.0	2,200	11,000	Storm Water	15.0	2,133	32,000	Storm Water	5.0	2,200	11,000
Receiving Building	1.0	1,250,000	1,250,000	Unused			-	Unused			-
<b>Subtotal</b>			<b>1,461,000</b>	<b>Subtotal</b>			<b>232,000</b>	<b>Subtotal</b>			<b>211,000</b>
<b>Processing Equip</b>				<b>Processing Equip</b>				<b>Processing Equip</b>			
Trommel	1.0	200,000	200,000	Trommel	1.0	200,000	200,000	Trommel	1.0	200,000	200,000
Tub Grinder	1.0	250,000	250,000	Tub Grinder	1.0	250,000	250,000	Tub Grinder	1.0	250,000	250,000
CASP System	1.0	1,400,000	1,400,000	Unused			-	CASP System	1.0	1,400,000	1,400,000
CASP Construction	1.0	1,800,000	1,800,000	Unused			-	CASP Construction	1.0	1,800,000	1,800,000
Gas Clean up (CNG)	1.0	3,113,000	3,113,000	Unused			-	Unused			-
Pipeline and Connect to											
WWTP	1.0	100,000	100,000	Unused			-	Unused			-
AD-C	1.0	2,500,000	2,500,000	Unused			-	Unused			-
Construction	1.0	2,500,000	2,500,000	Unused			-	Unused			-
<b>Total Equip</b>			<b>11,863,000</b>	<b>Total Equip</b>			<b>450,000</b>	<b>Total Equip</b>			<b>3,650,000</b>
<b>Rolling Stock</b>				<b>Rolling Stock</b>				<b>Rolling Stock</b>			
Loader	1.0	200,000	200,000	Loader	1.0	200,000	200,000	Loader	1.0	200,000	200,000
Unused			-	Water Truck	1.0	50,000	50,000	Unused			-
Unused			-	Unused			-	Unused			-
Unused			-	Unused			-	Unused			-
<b>Total Rolling Stock</b>			<b>200,000</b>	<b>Total Rolling Stock</b>			<b>250,000</b>	<b>Total Rolling Stock</b>			<b>200,000</b>
<b>Other Equipment</b>				<b>Other Equipment</b>				<b>Other Equipment</b>			
Scale	1.0	50,000	50,000	Scale	1.0	50,000	50,000	Scale	1.0	50,000	50,000
Cover Winder Machine	1.0	150,000	150,000	Unused			-	Cover Winder Machine	1.0	150,000	150,000
<b>Total Other equip</b>			<b>200,000</b>	<b>Total Other equip</b>			<b>50,000</b>	<b>Total Other equip</b>			<b>200,000</b>
<b>TOTAL</b>			<b>13,724,000</b>	<b>TOTAL</b>			<b>982,000</b>	<b>TOTAL</b>			<b>4,261,000</b>



**Financial Pro Forma**  
**for**  
**Project with only City Feedstock**

Basic Assumptions				
	SITE WWTP			
	Option A Composting  Covered Static Pile	Option B Composting  CASP	Option C AD & Composting AD-D & Covered Static Pile	Option D AD & Composting  AD-C & CASP
<b>Incoming Tons</b>				
TPD	48.0	48.0	48.0	48.0
TPY	12,672.0	12,672.0	12,672.0	12,672.0
<b>Commodity Sales</b>				
Compost TPY	8,448.0	8,448.0	6,336.0	6,336.0
Electricity kWh			1,201,652	
CNG Diesel gallon Equivalent				139,243
<b>Personnel (FTE)</b>	2.5	2.5	4.5	5.5
<b>Equipment</b>				
Trommel	1.0	1.0	1.0	1.0
Tub Grinder	1.0	1.0	1.0	1.0
Storage Tank	1.0		1.0	
CASP		1.0		
Loader	1.0	1.0	1.0	1.0
Cover Winder		1.0		1.0
AD-D			1.0	
Gas Cleanup			1.0	1.0
Pipeline Connection			1.0	1.0
AD-C				1.0
Water Truck	1.0		1.0	
<b>Facility</b>				
Site Prep & Storm Water	1.0	1.0	1.0	1.0
Building				1.0
Scale	1.0	1.0	1.0	1.0

## Financial Proforma

	SITE - WWTP							
	Option A Composting		Option B Composting		Option C AD & Composting AD-D & Covered Static Pile		Option D AD & Composting AD-C & CASP	
	Covered Static Pile		CASP		Covered Static Pile		AD-C & CASP	
	\$ Per Incoming ton	Annual	\$ Per Incoming ton	Annual	\$ Per Incoming ton	Annual	\$ Per Incoming ton	Annual
<b>Operations Costs</b>								
Labor	\$19.95	\$252,807	\$19.95	\$252,807	\$35.50	\$449,874	\$43.28	\$548,407
Equip Maint & Ops	\$3.58	\$45,408	\$5.08	\$64,344	\$13.45	\$170,408	\$22.83	\$289,344
<b>Sub-Total</b>	<b>\$23.53</b>	<b>\$298,215</b>	<b>\$25.03</b>	<b>\$317,151</b>	<b>\$48.95</b>	<b>\$620,282</b>	<b>\$66.11</b>	<b>\$837,751</b>
<b>Disposal Costs <sup>1</sup></b>								
Disposal - Residual Solid Waste Recovered/Diverted w/Negative Value	\$0.00	-	\$0.00	-	\$0.00	-	\$0.00	-
<b>Sub-Total</b>	<b>\$0.00</b>	<b>\$0</b>	<b>\$0.00</b>	<b>\$0</b>	<b>\$0.00</b>	<b>\$0</b>	<b>\$0.00</b>	<b>\$0</b>
<b>General &amp; Administrative Costs <sup>2</sup></b>								
Personnel <sup>3</sup>								
Facility G&A	\$3.98	\$50,400	\$3.98	\$50,400	\$3.98	\$50,400	\$3.98	\$50,400
<b>Sub-Total</b>	<b>\$3.98</b>	<b>\$50,400</b>	<b>\$3.98</b>	<b>\$50,400</b>	<b>\$3.98</b>	<b>\$50,400</b>	<b>\$3.98</b>	<b>\$50,400</b>
<b>Debt Service &amp; Equipment Replacement</b>								
Debt Service <sup>4</sup>	\$9.99	126,531	\$31.28	396,385	\$66.43	841,836	\$121.58	1,540,718
Equipment Replacement	\$6.93	\$87,857	\$23.84	\$302,143	\$51.28	\$649,857	\$88.66	\$1,123,443
<b>Sub-Total</b>	<b>\$16.92</b>	<b>\$214,388</b>	<b>\$55.12</b>	<b>\$698,528</b>	<b>\$117.71</b>	<b>\$1,491,694</b>	<b>\$210.24</b>	<b>\$2,664,161</b>
<b>Total Costs</b>	<b>\$44.43</b>	<b>\$563,003</b>	<b>\$84.13</b>	<b>\$1,066,079</b>	<b>\$170.64</b>	<b>\$2,162,376</b>	<b>\$280.33</b>	<b>\$3,552,312</b>
<b>Revenue from Commodity Sales</b>	\$13.33	\$168,961	\$13.33	\$168,961	\$25.74	\$326,195	\$54.28	\$687,870
<b>Net Cost</b>	<b>\$31.10</b>	<b>\$394,042</b>	<b>\$70.80</b>	<b>\$897,119</b>	<b>\$144.90</b>	<b>\$1,836,181</b>	<b>\$226.04</b>	<b>\$2,864,442</b>
<b>Incoming Tons</b>	12,672		12,672		12,672		12,672	

Notes

1. Assumes no disposal costs.
2. General and administrative costs are expenses required to administer a business, and which are not related to the construction, production or sale of goods or services.
3. No General & Administrative staff is included in this Pro-Forma.
4. This represents principal and interest.

### Incoming Tonnage & Products Generated

				Option A Composting	Option B Composting	Option C AD & Composting			Option D AD & Composting		
				Covered Static Pile	CASP	AD-D & Covered Static Pile			AD-C & CASP		
City of Davis	TPD	TPY	%	Compost	Compost	Compost	Electricity	Total	Compost	CNG	Total
Mixed GW & FW	26.00	6,864.0	54.2%								
GW Loose	18.0	4,752.0	37.5%								
Other Organics	4.0	1,056.0	8.3%								
<b>Total</b>	<b>48.0</b>	<b>12,672.0</b>	<b>100.0%</b>								
<b>UC Davis</b>											
Postconsumer FW		-	0.0%								
Digestate		-	0.0%								
Animal Bedding		-	0.0%								
GW		-	0.0%								
<b>Total</b>	<b>-</b>	<b>-</b>	<b>0.0%</b>								
<b>GRAND TOTAL</b>				<b>48.0</b>	<b>12,672.0</b>						
Compost Product Tons				8,448	8,448	6,336			6,336		
Biogas to Electricity Product (kWh)							1,201,652				
Biogas to Fuel Product (Diesel Gallon Equivalent)									139,243		
<b>Revenue per Unit</b>				\$20.00	\$20.00	\$20.00	\$0.166		\$20.00	\$4.03	
<b>Commodity Sales Revenue</b>				<b>\$168,961</b>	<b>\$168,961</b>	\$126,721	\$199,474	<b>\$326,195</b>	\$126,721	\$561,150	<b>\$687,870</b>
<b>Incoming Tons</b>				<b>12,672.0</b>	<b>12,672.0</b>	<b>12,672.0</b>			<b>12,672.0</b>		
% Tons to Composting Operation				100.0%	100.0%						
<b>Tons to Composting Operation</b>				<b>12,672.0</b>	<b>12,672.0</b>	-			-		
% Compost Production				66.667%	66.667%	66.7%			66.7%		
Compost Product				8,448.0	8,448.0	-			-		
<b>Tons to Digester</b>						12,672.0			12,672.0		
Tons to Composting Operation						9,504.0			9,504.0		
% Compost Production						66.7%			66.7%		
Compost Product						6,336.0			6,336.0		
<b>Total Compost Product Tons</b>				<b>8,448.0</b>	<b>8,448.0</b>	<b>6,336.0</b>			<b>6,336.0</b>		

**Direct Labor**

OPTION A WWTP - COMPOSTING Covered Static Pile	Annual Hours				Annual Labor Hours				Annual Labor Compensation																			
	Regular Hours	OT Hours	Total Weekly Hours	# of Shifts	Total Regular Hours	Total OT Hours	TOTAL HOURS	Crew Size	Total Crew	Total Regular Hours	Total OT Hours	TOTAL HOURS	Regular Rate	OT Rate	Regular Wages	OT Wages	Holiday Wages	Vacation Wages	Sick Leave Wages	Pension	Medical	Total Compensation	WC Factor	WC Rate	WC Expense	Unifor m	Payroll Tax	Wages Expense
Supervisor/GM	20.0	-	20.0	1.00	1,040.0	-	1,040.0	1.00	1.00	880.0	-	880.0	40.00	60.00	35,200	-	2,880	4,800	1,600	2,640	14,400	61,520	445	10.00	4,448	-	5,229	71,197
Equipment Operators	40.0	-	40.0	1.00	2,080.0	-	2,080.0	1.00	1.00	1,920.0	-	1,920.0	30.00	45.00	57,600	-	2,160	3,600	1,200	5,760	14,400	84,720	646	10.00	6,456	-	7,201	98,377
Laborer	40.0	-	40.0	1.00	2,080.0	-	2,080.0	1.00	1.00	1,968.0	-	1,968.0	24.00	36.00	47,232	-	1,728	1,920	768	5,904	14,400	71,952	516	10.00	5,165	-	6,116	83,233
Unused	-	-	-	-	-	-	-	-	-	-	-	-	-	-	-	-	-	-	-	-	-	-	-	-	-	-	-	-
					5,200.0	-	5,200.0	3.00	3.00	4,768.0	-	4,768.0			140,032	-	6,768	10,320	3,568	14,304	43,200	218,192			16,069	-	18,546	252,807
<b>OPTION B</b>																												
<b>WWTP - COMPOSTING CASP</b>																												
Supervisor/GM	20.0	-	20.0	1.00	1,040.0	-	1,040.0	1.00	1.00	880.0	-	880.0	40.00	60.00	35,200	-	2,880	4,800	1,600	2,640	14,400	61,520	445	10.00	4,448	-	5,229	71,197
Equipment Operators	40.0	-	40.0	1.00	2,080.0	-	2,080.0	1.00	1.00	1,920.0	-	1,920.0	30.00	45.00	57,600	-	2,160	3,600	1,200	5,760	14,400	84,720	646	10.00	6,456	-	7,201	98,377
Laborer	40.0	-	40.0	1.00	2,080.0	-	2,080.0	1.00	1.00	1,968.0	-	1,968.0	24.00	36.00	47,232	-	1,728	1,920	768	5,904	14,400	71,952	516	10.00	5,165	-	6,116	83,233
Unused	-	-	-	-	-	-	-	-	-	-	-	-	-	-	-	-	-	-	-	-	-	-	-	-	-	-	-	-
					5,200.0	-	5,200.0	3.00	3.00	4,768.0	-	4,768.0			140,032	-	6,768	10,320	3,568	14,304	43,200	218,192			16,069	-	18,546	252,807
<b>OPTION C</b>																												
<b>WWTP - AD &amp; COMPOSTING</b>																												
Supervisor	20.0	-	20.0	1.00	1,040.0	-	1,040.0	1.00	1.00	880.0	-	880.0	40.00	60.00	35,200	-	2,880	4,800	1,600	2,640	14,400	61,520	445	10.00	4,448	-	5,229	71,197
AD Operator Maintenance	40.0	-	40.0	1.00	2,080.0	-	2,080.0	1.00	1.00	1,920.0	-	1,920.0	30.00	45.00	57,600	-	2,160	3,600	1,200	5,760	14,400	84,720	646	10.00	6,456	-	7,201	98,377
AD Loader	40.0	-	40.0	1.00	2,080.0	-	2,080.0	1.00	1.00	1,968.0	-	1,968.0	30.00	45.00	59,040	-	2,160	2,400	960	5,904	14,400	84,864	646	10.00	6,456	-	7,213	98,533
Equipment Operators	40.0	-	40.0	1.00	2,080.0	-	2,080.0	1.00	1.00	1,968.0	-	1,968.0	30.00	45.00	59,040	-	2,160	2,400	960	5,904	14,400	84,864	646	10.00	6,456	-	7,213	98,533
Laborer	40.0	-	40.0	1.00	2,080.0	-	2,080.0	1.00	1.00	1,968.0	-	1,968.0	24.00	36.00	47,232	-	1,728	1,920	768	5,904	14,400	71,952	516	10.00	5,165	-	6,116	83,233
Unused	-	-	-	-	-	-	-	-	-	-	-	-	-	-	-	-	-	-	-	-	-	-	-	-	-	-	-	-
					9,360.0	-	9,360.0	5.00	5.00	8,704.0	-	8,704.0			258,112	-	11,088	15,120	5,488	26,112	72,000	387,920			28,981	-	32,973	449,874
<b>OPTION D</b>																												
<b>WWTP - AD &amp; COMPOSTING</b>																												
Supervisor	20.0	-	20.0	1.00	1,040.0	-	1,040.0	1.00	1.00	880.0	-	880.0	40.00	60.00	35,200	-	2,880	4,800	1,600	2,640	14,400	61,520	445	10.00	4,448	-	5,229	71,197
AD Electrician	40.0	-	40.0	1.00	2,080.0	-	2,080.0	1.00	1.00	1,920.0	-	1,920.0	30.00	45.00	57,600	-	2,160	3,600	1,200	5,760	14,400	84,720	646	10.00	6,456	-	7,201	98,377
Mechanic	40.0	-	40.0	1.00	2,080.0	-	2,080.0	1.00	1.00	1,968.0	-	1,968.0	30.00	45.00	59,040	-	2,160	2,400	960	5,904	14,400	84,864	646	10.00	6,456	-	7,213	98,533
Plumber	40.0	-	40.0	1.00	2,080.0	-	2,080.0	1.00	1.00	1,968.0	-	1,968.0	30.00	45.00	59,040	-	2,160	2,400	960	5,904	14,400	84,864	646	10.00	6,456	-	7,213	98,533
Equipment Operators	40.0	-	40.0	1.00	2,080.0	-	2,080.0	1.00	1.00	1,968.0	-	1,968.0	30.00	45.00	59,040	-	2,160	2,400	960	5,904	14,400	84,864	646	10.00	6,456	-	7,213	98,533
Laborer	40.0	-	40.0	1.00	2,080.0	-	2,080.0	1.00	1.00	1,968.0	-	1,968.0	24.00	36.00	47,232	-	1,728	1,920	768	5,904	14,400	71,952	516	10.00	5,165	-	6,116	83,233
Unused	-	-	-	-	-	-	-	-	-	-	-	-	-	-	-	-	-	-	-	-	-	-	-	-	-	-	-	-
					11,440.0	-	11,440.0	6.00	6.00	10,672.0	-	10,672.0			317,152	-	13,248	17,520	6,448	32,016	86,400	472,784			35,437	-	40,187	548,407

## Annual General Admin Expenses

Cost Category	Option A Composting	Option B Composting	Option C AD & Composting	Option D AD & Composting
	Covered Static Pile	CASP	AD-D & Covered Static Pile	AD-C & CASP
Utilities	2,400	2,400	2,400	2,400
Telephone	6,000	6,000	6,000	6,000
Information Technology	18,000	18,000	18,000	18,000
Office Supplies	6,000	6,000	6,000	6,000
Facility/Landscaping	-	-	-	-
Janitorial	6,000	6,000	6,000	6,000
Operating Supplies	6,000	6,000	6,000	6,000
Personal Protection Equipment	6,000	6,000	6,000	6,000
<b>TOTAL</b>	<b>50,400</b>	<b>50,400</b>	<b>50,400</b>	<b>50,400</b>

## Equipment Operating Expenditures

						WWTP			
						OPTION A Composting	OPTION B Composting	Option C AD & Composting	Option D AD & Composting
Equipment	Hours per Day	Hours per Month <sup>1</sup>	\$/Hour <sup>2</sup>	Monthly Expense	Annual Expense	Covered Static Pile	CASP	AD-D & Covered Static Pile	AD-C & CASP
Trommel	1.0	22.0	26.00	\$ 572	\$ 6,864	\$ 6,864	\$ 6,864	\$ 6,864	\$ 6,864
Tub Grinder	0.5	11.0	40.00	\$ 440	\$ 5,280	\$ 5,280	\$ 5,280	\$ 5,280	\$ 5,280
Loader	2.0	44.0	50.00	\$ 2,200	\$ 26,400	\$ 26,400	\$ 26,400	\$ 26,400	\$ 26,400
Water Truck	1.0	22.0	26.00	\$ 572	\$ 6,864	\$ 6,864	\$ 6,864	\$ 6,864	\$ 6,864
CASP						\$ 25,800			\$ 25,800
AD-D							\$ 75,000		
AD-C									\$ 75,000
Gas Cleanup							\$ 50,000		\$ 150,000
<b>Total OPEX</b>						<b>\$ 45,408</b>	<b>\$ 64,344</b>	<b>\$ 170,408</b>	<b>\$ 289,344</b>
<p>Notes</p> <p>1. Assumes 264 days per year.</p> <p>2. Includes fuel and maintenance if applicable.</p>									

## Debt Service

	WWTP OPTION A COMPOSTING  COVERED STATIC PILE	WWTP OPTION B COMPOSTING  CASP	WWTP Option C AD & Composting AD-D & Covered Static Pile	WWTP Option D AD & Composting  AD-C & CASP
<b>1 Building / Facility</b>				
Loan Amount (\$)	\$ 232,000	\$ 211,000	\$ 232,000	\$ 1,461,000
Interest Rate (%)	5.00%	5.00%	5.00%	5.00%
Term (Years)	20	20	20	20
No. Payments	240	240	240	240
Monthly Payment	\$ 1,531	\$ 1,393	\$ 1,531	\$ 9,642
Interest Expense (\$/year)	\$ 11,443	\$ 10,407	\$ 11,443	\$ 72,059
Principal Payment (\$/year)	\$ 6,931	\$ 6,303	\$ 6,931	\$ 43,645
Total Payments (\$/year)	\$ 18,373	\$ 16,710	\$ 18,373	\$ 115,703
Replacement fund	\$ -	\$ -	\$ -	\$ -
<b>2 Processing Equipment</b>				
Loan Amount (\$)	\$ 450,000	\$ 2,450,000	\$ 6,070,000	\$ 10,663,000
Interest Rate (%)	5.00%	5.00%	5.00%	5.00%
Term (Years)	10	10	10	10
No. Payments	120	120	120	120
Monthly Payment	\$ 4,773	\$ 25,986	\$ 64,382	\$ 113,098
Interest Expense (\$/year)	\$ 21,692	\$ 118,100	\$ 292,600	\$ 514,001
Principal Payment (\$/year)	\$ 35,583	\$ 193,732	\$ 479,982	\$ 843,170
Total Payments (\$/year)	\$ 57,275	\$ 311,833	\$ 772,581	\$ 1,357,172
Replacement fund	\$ 45,000	\$ 245,000	\$ 607,000	\$ 1,066,300



## Debt Service

	WWTP OPTION A COMPOSTING		WWTP OPTION B COMPOSTING		WWTP Option C AD & Composting AD-D & Covered Static Pile		WWTP Option D AD & Composting AD-C & CASP	
	COVERED STATIC PILE		CASP					
<b>3 Rolling Stock</b>								
Loan Amount (\$)	\$	250,000	\$	200,000	\$	250,000	\$	200,000
Interest Rate (%)		5.00%		5.00%		5.00%		5.00%
Term (Years)		7		7		7		7
No. Payments		84		84		84		84
Monthly Payment	\$	3,533	\$	2,827	\$	3,533	\$	2,827
Interest Expense (\$/year)	\$	11,805	\$	9,444	\$	11,805	\$	9,444
Principal Payment (\$/year)	\$	30,597	\$	24,477	\$	30,597	\$	24,477
Total Payments (\$/year)	\$	42,402	\$	33,921	\$	42,402	\$	33,921
Replacement fund	\$	35,714	\$	28,571	\$	35,714	\$	28,571
<b>4 Other Equipment</b>								
Loan Amount (\$)	\$	50,000	\$	200,000	\$	50,000	\$	200,000
Interest Rate (%)		5.00%		5.00%		5.00%		5.00%
Term (Years)		7		7		7		7
No. Payments		84		84		84		84
Monthly Payment	\$	707	\$	2,827	\$	707	\$	2,827
Interest Expense (\$/year)	\$	2,361	\$	9,444	\$	2,361	\$	9,444
Principal Payment (\$/year)	\$	6,119	\$	24,477	\$	6,119	\$	24,477
Total Payments (\$/year)	\$	8,480	\$	33,921	\$	8,480	\$	33,921
Replacement fund	\$	7,143	\$	28,571	\$	7,143	\$	28,571
<b>5 TOTAL</b>								
Loan Amount (\$)	\$	982,000	\$	3,061,000	\$	6,602,000	\$	12,524,000
Monthly Payment	\$	10,544	\$	33,032	\$	70,153	\$	128,393
Interest Expense (\$/year)	\$	47,301	\$	147,395	\$	318,208	\$	604,948
Principal Payment (\$/year)	\$	79,230	\$	248,990	\$	523,628	\$	935,770
Total Payments (\$/year)	\$	126,531	\$	396,385	\$	841,836	\$	1,540,718
Replacement fund	\$	87,857	\$	302,143	\$	649,857	\$	1,123,443

## Capital Expenditures

WWTP							
OPTION A - COMPOSTING COVERED STATIC PILE				OPTION B - COMPOSTING CASP			
Building / Facility	Qty	Price	Total	Building / Facility	Qty	Price	Total
Site Preparation	1.0	200,000	200,000	Site Preparation	1.0	200,000	200,000
Storm Water	15.0	2,133	32,000	Storm Water	5.0	2,200	11,000
Unused			-	Unused			-
<b>Total Building / Facility</b>			<b>232,000</b>	<b>Total Building / Facility</b>			<b>211,000</b>
<b>Processing Equip</b>				<b>Processing Equip</b>			
Trommel	1.0	200,000	200,000	Trommel	1.0	200,000	200,000
Tub Grinder	1.0	250,000	250,000	Tub Grinder	1.0	250,000	250,000
Unused			-	CASP System	1.0	1,000,000	1,000,000
Unused			-	CASP Construction	1.0	1,000,000	1,000,000
Unused			-	Unused			-
Unused			-				-
Unused			-				-
<b>Total Equip</b>			<b>450,000</b>	<b>Total Equip</b>			<b>2,450,000</b>
<b>Rolling Stock</b>				<b>Rolling Stock</b>			
Loader	1.0	200,000	200,000	Loader	1.0	200,000	200,000
Water Truck	1.0	50,000	50,000	Unused			-
Unused			-	Unused			-
Unused			-	Unused			-
<b>Total Rolling Stock</b>			<b>250,000</b>	<b>Total Rolling Stock</b>			<b>200,000</b>
<b>Other Equipment</b>				<b>Other Equipment</b>			
Scale	1.0	50,000	50,000	Scale	1.0	50,000	50,000
Unused			-	Cover Winder Machine	1.0	150,000	150,000
<b>Total Other equip</b>			<b>50,000</b>	<b>Total Other equip</b>			<b>200,000</b>
<b>TOTAL</b>			<b>982,000</b>	<b>TOTAL</b>			<b>3,061,000</b>

## Capital Expenditures

WWTP							
Option C - AD & Composting AD-D & Covered Static Pile				Option D - AD & Composting AD-C & CASP			
Building / Facility	Qty	Price	Total	Building / Facility	Qty	Price	Total
Site Preparation	1.0	200,000	200,000	Site Preparation	1.0	200,000	200,000
Storm Water	15.0	2,133	32,000	Storm Water	5.0	2,200	11,000
Unused			-	Receiving Building	1.0	1,250,000	1,250,000
<b>Total Building / Facility</b>			<b>232,000</b>	<b>Total Building / Facility</b>			<b>1,461,000</b>
<b>Processing Equip</b>				<b>Processing Equip</b>			
Trommel	1.0	200,000	200,000	Trommel	1.0	200,000	200,000
Tub Grinder	1.0	250,000	250,000	Tub Grinder	1.0	250,000	250,000
AD-D	1.0	2,000,000	2,000,000	CASP System	1.0	1,000,000	1,000,000
Construction	1.0	3,270,000	3,270,000	CASP Construction	1.0	1,000,000	1,000,000
Gas Clean up (CoGen)	1.0	250,000	250,000	Gas Clean up (CNG)	1.0	3,113,000	3,113,000
Pipeline and Connect to WWTP	1.0	100,000	100,000	Pipeline and Connect to WWTP	1.0	100,000	100,000
<b>Total Equip</b>			<b>6,070,000</b>	<b>Total Equip</b>			<b>10,663,000</b>
<b>Rolling Stock</b>				<b>Rolling Stock</b>			
Loader	1.0	200,000	200,000	Loader	1.0	200,000	200,000
Water Truck	1.0	50,000	50,000	Unused			-
Unused			-	Unused			-
Unused			-	Unused			-
<b>Total Rolling Stock</b>			<b>250,000</b>	<b>Total Rolling Stock</b>			<b>200,000</b>
<b>Other Equipment</b>				<b>Other Equipment</b>			
Scale	1.0	50,000	50,000	Scale	1.0	50,000	50,000
Unused			-	Cover Winder Machine	1.0	150,000	150,000
<b>Total Other equip</b>			<b>50,000</b>	<b>Total Other equip</b>			<b>200,000</b>
<b>TOTAL</b>			<b>6,602,000</b>	<b>TOTAL</b>			<b>12,524,000</b>

**Financial Pro Forma**

**for**

**Project with four times the City feedstock  
to represent a large-scale regional project**

Basic Assumptions						
	SITE WWTP				SITE UC DAVIS	
	Option A Composting	Option B Composting	Option C AD & Composting AD-D &	Option D AD & Composting	Option E Composting	Option F Composting
	Covered Static Pile	CASP	Covered Static Pile	AD-C & CASP	Covered Static Pile	CASP
<b>Incoming Tons</b>						
TPD	192.0	192.0	192.0	192.0	192.0	192.0
TPY	50,688.0	50,688.0	50,688.0	50,688.0	50,688.0	50,688.0
<b>Commodity Sales</b>						
Compost TPY	33,792.2	33,792.2	25,344.1	25,344.1	33,792.2	33,792.2
Electricity kWh			4,806,607			
CNG Diesel gallon Equivalent				556,972		
<b>Personnel (FTE)</b>	7.5	6.5	8.0	8.0	7.5	6.5
<b>Equipment</b>						
Trommel	1.0	1.0	1.0	1.0	1.0	1.0
Tub Grinder	1.0	1.0	1.0	1.0	1.0	1.0
Storage Tank	1.0		1.0		1.0	
CASP		1.0				1.0
Loader	1.0	1.0	1.0	1.0	1.0	1.0
Cover Winder		1.0		1.0		
AD-D			1.0			
Gas Cleanup			1.0	1.0		
Pipeline Connection			1.0	1.0		
AD-C				1.0		
Water Truck	1.0		1.0		1.0	
<b>Facility</b>						
Site Prep & Storm Water	1.0	1.0	1.0	1.0	1.0	1.0
Building				1.0		
Scale	1.0	1.0	1.0	1.0	1.0	1.0

## Financial Proforma

	SITE - WWTP						SITE - UC DAVIS					
	Option A Composting		Option B Composting		Option C AD & Composting AD-D & Covered Static Pile		Option D AD & Composting AD-C & CASP		Option E Composting		Option F Composting	
	Covered Static Pile		CASP		Covered Static Pile		AD-C & CASP		Covered Static Pile		CASP	
	\$ Per Incoming ton      Annual		\$ Per Incoming ton      Annual		\$ Per Incoming ton      Annual		\$ Per Incoming ton      Annual		\$ Per Incoming ton      Annual		\$ Per Incoming ton      Annual	
<b>Operations Costs</b>												
Labor	\$14.10	\$714,560	\$12.46	\$631,328	\$15.44	\$782,855	\$15.75	\$798,156	\$14.10	\$714,560	\$12.46	\$631,328
Equip Maint & Ops	\$5.92	\$299,904	\$5.34	\$270,792	\$8.38	\$424,904	\$9.78	\$495,792	\$5.92	\$299,904	\$5.34	\$270,792
<b>Sub-Total</b>	<b>\$20.02</b>	<b>\$1,014,464</b>	<b>\$17.80</b>	<b>\$902,120</b>	<b>\$23.82</b>	<b>\$1,207,759</b>	<b>\$25.53</b>	<b>\$1,293,948</b>	<b>\$20.02</b>	<b>\$1,014,464</b>	<b>\$17.80</b>	<b>\$902,120</b>
<b>Disposal Costs <sup>1</sup></b>												
Disposal - Residual Solid Waste Recovered/Diverted w/Negative Value	\$0.00	-	\$0.00	-	\$0.00	-	\$0.00	-	\$0.00	-	\$0.00	-
<b>Sub-Total</b>	<b>\$0.00</b>	<b>\$0</b>	<b>\$0.00</b>	<b>\$0</b>	<b>\$0.00</b>	<b>\$0</b>	<b>\$0.00</b>	<b>\$0</b>	<b>\$0.00</b>	<b>\$0</b>	<b>\$0.00</b>	<b>\$0</b>
<b>General &amp; Administrative Costs <sup>2</sup></b>												
Personnel <sup>3</sup>												
Facility G&A	\$0.99	\$50,400	\$0.99	\$50,400	\$0.99	\$50,400	\$0.99	\$50,400	\$0.99	\$50,400	\$0.99	\$50,400
<b>Sub-Total</b>	<b>\$0.99</b>	<b>\$50,400</b>	<b>\$0.99</b>	<b>\$50,400</b>	<b>\$0.99</b>	<b>\$50,400</b>	<b>\$0.99</b>	<b>\$50,400</b>	<b>\$0.99</b>	<b>\$50,400</b>	<b>\$0.99</b>	<b>\$50,400</b>
<b>Debt Service &amp; Equipment Replacement</b>												
Debt Service <sup>4</sup>	\$2.65	134,450	\$18.27	926,147	\$54.38	2,756,390	\$76.29	3,866,763	\$2.65	134,450	\$18.27	926,147
Equipment Replacement	\$1.73	\$87,857	\$14.05	\$712,143	\$42.37	\$2,147,857	\$58.10	\$2,944,743	\$1.73	\$87,857	\$14.05	\$712,143
<b>Sub-Total</b>	<b>\$4.38</b>	<b>\$222,307</b>	<b>\$32.32</b>	<b>\$1,638,290</b>	<b>\$96.75</b>	<b>\$4,904,247</b>	<b>\$134.39</b>	<b>\$6,811,506</b>	<b>\$4.38</b>	<b>\$222,307</b>	<b>\$32.32</b>	<b>\$1,638,290</b>
<b>Total Costs</b>	<b>\$25.39</b>	<b>\$1,287,172</b>	<b>\$51.11</b>	<b>\$2,590,810</b>	<b>\$121.58</b>	<b>\$6,162,406</b>	<b>\$160.90</b>	<b>\$8,155,853</b>	<b>\$25.39</b>	<b>\$1,287,172</b>	<b>\$51.11</b>	<b>\$2,590,810</b>
<b>Revenue from Commodity Sales</b>	\$13.33	\$675,843	\$13.33	\$675,843	\$25.74	\$1,304,779	\$54.28	\$2,751,481	\$13.33	\$675,843	\$13.33	\$675,843
<b>Net Cost</b>	<b>\$12.06</b>	<b>\$611,328</b>	<b>\$37.78</b>	<b>\$1,914,966</b>	<b>\$95.83</b>	<b>\$4,857,626</b>	<b>\$106.62</b>	<b>\$5,404,372</b>	<b>\$12.06</b>	<b>\$611,328</b>	<b>\$37.78</b>	<b>\$1,914,966</b>
<b>Incoming Tons</b>	50,688		50,688		50,688		50,688		50,688		50,688	

Notes

1. Assumes no disposal costs.
2. General and administrative costs are expenses required to administer a business, and which are not related to the construction, production or sale of goods or services.
3. No General & Administrative staff is included in this Pro-Forma.
4. This represents principal and interest.

### Incoming Tonnage & Products Generated

				Option A Composting	Option B Composting	Option C AD & Composting			Option D AD & Composting			Option E Composting	Option F Composting
				Covered Static Pile	CASP	AD-D & Covered Static Pile			AD-C & CASP			Covered Static Pile	CASP
City of Davis	TPD	TPY	%	Compost	Compost	Compost	Electricity	Total	Compost	CNG	Total	Compost	Compost
Mixed GW & FW	104.00	27,456.0	54.2%										
GW Loose	72.0	19,008.0	37.5%										
Other Organics	16.0	4,224.0	8.3%										
<b>Total</b>	<b>192.0</b>	<b>50,688.0</b>	<b>100.0%</b>										
<b>UC Davis</b>													
Postconsumer FW		-	0.0%										
Digestate		-	0.0%										
Animal Bedding		-	0.0%										
GW		-	0.0%										
<b>Total</b>	<b>-</b>	<b>-</b>	<b>0.0%</b>										
<b>GRAND TOTAL</b>	<b>192.0</b>	<b>50,688.0</b>											
Compost Product Tons				33,792	33,792	25,344			25,344			33,792	33,792
Biogas to Electricity Product (kWh)							4,806,607						
Biogas to Fuel Product (Diesel Gallon Equivalent)									556,972				
<b>Revenue per Unit</b>				\$20.00	\$20.00	\$20.00	\$0.166		\$20.00	\$4.03		\$20.00	\$20.00
<b>Commodity Sales Revenue</b>				<b>\$675,843</b>	<b>\$675,843</b>	<b>\$506,883</b>	<b>\$797,897</b>	<b>\$1,304,779</b>	<b>\$506,883</b>	<b>\$2,244,599</b>	<b>\$2,751,481</b>	<b>\$675,843</b>	<b>\$675,843</b>

<b>Incoming Tons</b>	<b>50,688.0</b>	<b>50,688.0</b>	<b>50,688.0</b>	<b>50,688.0</b>	<b>50,688.0</b>	<b>50,688.0</b>
% Tons to Composting Operation	100.0%	100.0%			100.0%	100.0%
<b>Tons to Composting Operation</b>	<b>50,688.0</b>	<b>50,688.0</b>	-		-	<b>50,688.0</b>
% Compost Production	66.667%	66.667%	66.7%		66.7%	66.667%
Compost Product	33,792.2	33,792.2	-		-	33,792.2
<b>Tons to Digester</b>			50,688.0		50,688.0	
Tons to Composting Operation			38,016.0		38,016.0	
% Compost Production			66.7%		66.7%	
Compost Product			25,344.1		25,344.1	
<b>Total Compost Product Tons</b>	<b>33,792.2</b>	<b>33,792.2</b>	<b>25,344.1</b>		<b>25,344.1</b>	<b>33,792.2</b>

**Direct Labor**

OPTION A WWTP - COMPOSTING Covered Static Pile	Annual Hours				Annual Labor Hours				Annual Labor Compensation																			
	Regular Hours	OT Hours	Total Weekly Hours	# of Shifts	Total Regular Hours	Total OT Hours	TOTAL HOURS	Crew Size	Total Crew	Total Regular Hours	Total OT Hours	TOTAL HOURS	Regular Rate	OT Rate	Regular Wages	OT Wages	Holiday Wages	Vacation Wages	Sick Leave Wages	Pension	Medical	Total Compensation	WC Factor	WC Rate	WC Expense	Unifor m	Payroll Tax	Wages Expense
Supervisor/GM	20.0	-	20.0	1.00	1,040.0	-	1,040.0	1.00	1.00	880.0	-	880.0	40.00	60.00	35,200	-	2,880	4,800	1,600	2,640	14,400	61,520	445	10.00	4,448	-	5,229	71,197
Equipment Operators	40.0	-	40.0	1.00	2,080.0	-	2,080.0	3.00	3.00	5,760.0	-	5,760.0	30.00	45.00	172,800	-	6,480	10,800	3,600	17,280	43,200	254,160	1,937	10.00	19,368	-	21,604	295,132
Laborer	40.0	-	40.0	1.00	2,080.0	-	2,080.0	3.00	3.00	5,904.0	-	5,904.0	24.00	36.00	141,696	-	5,184	5,760	2,304	17,712	43,200	215,856	1,549	10.00	15,494	-	18,348	249,698
Maintenance	40.0	-	40.0	1.00	2,080.0	-	2,080.0	1.00	1.00	1,968.0	-	1,968.0	30.00	45.00	59,040	-	2,160	2,400	960	5,904	14,400	84,864	646	10.00	6,456	-	7,213	98,533
					7,280.0	-	7,280.0	8.00	8.00	14,512.0	-	14,512.0			408,736	-	16,704	23,760	8,464	43,536	115,200	616,400			45,766	-	52,394	714,560
<b>OPTION B</b>																												
<b>WWTP - COMPOSTING CASP</b>																												
Supervisor/GM	20.0	-	20.0	1.00	1,040.0	-	1,040.0	1.00	1.00	880.0	-	880.0	40.00	60.00	35,200	-	2,880	4,800	1,600	2,640	14,400	61,520	445	10.00	4,448	-	5,229	71,197
Equipment Operators	40.0	-	40.0	1.00	2,080.0	-	2,080.0	3.00	3.00	5,760.0	-	5,760.0	30.00	45.00	172,800	-	6,480	10,800	3,600	17,280	43,200	254,160	1,937	10.00	19,368	-	21,604	295,132
Laborer	40.0	-	40.0	1.00	2,080.0	-	2,080.0	2.00	2.00	3,936.0	-	3,936.0	24.00	36.00	94,464	-	3,456	3,840	1,536	11,808	28,800	143,904	1,033	10.00	10,330	-	12,232	166,465
Maintenance	40.0	-	40.0	1.00	2,080.0	-	2,080.0	1.00	1.00	1,968.0	-	1,968.0	30.00	45.00	59,040	-	2,160	2,400	960	5,904	14,400	84,864	646	10.00	6,456	-	7,213	98,533
					7,280.0	-	7,280.0	7.00	7.00	12,544.0	-	12,544.0			361,504	-	14,976	21,840	7,696	37,632	100,800	544,448			40,602	-	46,278	631,328
<b>OPTION C</b>																												
<b>WWTP - AD &amp; COMPOSTING</b>																												
Supervisor	40.0	-	40.0	1.00	2,080.0	-	2,080.0	1.00	1.00	1,920.0	-	1,920.0	40.00	60.00	76,800	-	2,880	4,800	1,600	5,760	14,400	106,240	861	10.00	8,608	-	9,030	123,878
AD Operator Maintenance	40.0	-	40.0	1.00	2,080.0	-	2,080.0	1.00	1.00	1,920.0	-	1,920.0	30.00	45.00	57,600	-	2,160	3,600	1,200	5,760	14,400	84,720	646	10.00	6,456	-	7,201	98,377
AD Loader	40.0	-	40.0	1.00	2,080.0	-	2,080.0	1.00	1.00	1,968.0	-	1,968.0	30.00	45.00	59,040	-	2,160	2,400	960	5,904	14,400	84,864	646	10.00	6,456	-	7,213	98,533
Equipment Operators	40.0	-	40.0	1.00	2,080.0	-	2,080.0	2.00	2.00	3,936.0	-	3,936.0	30.00	45.00	118,080	-	4,320	4,800	1,920	11,808	28,800	169,728	1,291	10.00	12,912	-	14,427	197,067
Laborer	40.0	-	40.0	1.00	2,080.0	-	2,080.0	2.00	2.00	3,936.0	-	3,936.0	24.00	36.00	94,464	-	3,456	3,840	1,536	11,808	28,800	143,904	1,033	10.00	10,330	-	12,232	166,465
Maintenance	40.0	-	40.0	1.00	2,080.0	-	2,080.0	1.00	1.00	1,968.0	-	1,968.0	30.00	45.00	59,040	-	2,160	2,400	960	5,904	14,400	84,864	646	10.00	6,456	-	7,213	98,533
					12,480.0	-	12,480.0	8.00	8.00	15,648.0	-	15,648.0			465,024	-	17,136	21,840	8,176	46,944	115,200	674,320			51,218	-	57,317	782,855
<b>OPTION D</b>																												
<b>WWTP - AD &amp; COMPOSTING</b>																												
Supervisor	40.0	-	40.0	1.00	2,080.0	-	2,080.0	1.00	1.00	1,920.0	-	1,920.0	40.00	60.00	76,800	-	2,880	4,800	1,600	5,760	14,400	106,240	861	10.00	8,608	-	9,030	123,878
AD Electrician	40.0	-	40.0	1.00	2,080.0	-	2,080.0	1.00	1.00	1,920.0	-	1,920.0	30.00	45.00	57,600	-	2,160	3,600	1,200	5,760	14,400	84,720	646	10.00	6,456	-	7,201	98,377
Mechanic	40.0	-	40.0	1.00	2,080.0	-	2,080.0	1.00	1.00	1,968.0	-	1,968.0	30.00	45.00	59,040	-	2,160	2,400	960	5,904	14,400	84,864	646	10.00	6,456	-	7,213	98,533
Plumber	40.0	-	40.0	1.00	2,080.0	-	2,080.0	1.00	1.00	1,968.0	-	1,968.0	30.00	45.00	59,040	-	2,160	2,400	960	5,904	14,400	84,864	646	10.00	6,456	-	7,213	98,533
Equipment Operators	40.0	-	40.0	1.00	2,080.0	-	2,080.0	2.00	2.00	3,936.0	-	3,936.0	30.00	45.00	118,080	-	4,320	4,800	1,920	11,808	28,800	169,728	1,291	10.00	12,912	-	14,427	197,067
Laborer	40.0	-	40.0	1.00	2,080.0	-	2,080.0	1.00	1.00	1,968.0	-	1,968.0	24.00	36.00	47,232	-	1,728	1,920	768	5,904	14,400	71,952	516	10.00	5,165	-	6,116	83,233
Maintenance	40.0	-	40.0	1.00	2,080.0	-	2,080.0	1.00	1.00	1,968.0	-	1,968.0	30.00	45.00	59,040	-	2,160	2,400	960	5,904	14,400	84,864	646	10.00	6,456	-	7,213	98,533
					14,560.0	-	14,560.0	8.00	8.00	15,648.0	-	15,648.0			476,832	-	17,568	22,320	8,368	46,944	115,200	687,232			52,509	-	58,415	798,156
<b>OPTION E</b>																												
<b>UC DAVIS - COMPOSTING</b>																												
<b>Covered Static Pile</b>																												
Supervisor/GM	20.0	-	20.0	1.00	1,040.0	-	1,040.0	1.00	1.00	880.0	-	880.0	40.00	60.00	35,200	-	2,880	4,800	1,600	2,640	14,400	61,520	445	10.00	4,448	-	5,229	71,197
Equipment Operators	40.0	-	40.0	1.00	2,080.0	-	2,080.0	3.00	3.00	5,760.0	-	5,760.0	30.00	45.00	172,800	-	6,480	10,800	3,600	17,280	43,200	254,160	1,937	10.00	19,368	-	21,604	295,132
Laborer	40.0	-	40.0	1.00	2,080.0	-	2,080.0	3.00	3.00	5,904.0	-	5,904.0	24.00	36.00	141,696	-	5,184	5,760	2,304	17,712	43,200	215,856	1,549	10.00	15,494	-	18,348	249,698
Maintenance	40.0	-	40.0	1.00	2,080.0	-	2,080.0	1.00	1.00	1,968.0	-	1,968.0	30.00	45.00	59,040	-	2,160	2,400	960	5,904	14,400	84,864	646	10.00	6,456	-	7,213	98,533
					7,280.0	-	7,280.0	8.00	8.00	14,512.0	-	14,512.0			408,736	-	16,704	23,760	8,464	43,536	115,200	616,400			45,766	-	52,394	714,560
<b>OPTION F</b>																												
<b>UC DAVIS - COMPOSTING</b>																												
<b>CASP</b>																												
Supervisor/GM	20.0	-	20.0	1.00	1,040.0	-	1,040.0	1.00	1.00	880.0	-	880.0	40.00	60.00	35,200	-	2,880	4,800	1,600	2,640	14,400	61,520	445	10.00	4,448	-	5,229	71,197
Equipment Operators	40.0	-	40.0	1.00	2,080.0	-	2,080.0	3.00	3.00	5,760.0	-	5,760.0	30.00	45.00	172,800	-	6,480	10,800	3,600	17,280	43,200	254,160	1,937	10.00	19,368	-	21,604	295,132
Laborer	40.0	-	40.0	1.00	2,080.0	-	2,080.0	2.00	2.00	3,936.0	-	3,936.0	24.00	36.00	94,464	-	3,456	3,840	1,536	11,808	28,800	143,904	1,033	10.00	10,330	-	12,232	166,465
Maintenance	40.0	-	40.0	1.00	2,080.0	-	2,080.0	1.00	1.00	1,968.0	-	1,968.0	30.00	45.00	59,040	-	2,160	2,400	960	5,904	14,400	84,864	646	10.00	6,456	-	7,213	98,533
					7,280.0	-	7,280.0	7.00	7.00	12,544.0	-	12,544.0			361,504	-	14,976	21,840	7,696	37,632	100,800	544,448			40,602	-	46,278	631,328



### Annual General Admin Expenses

	Option A Composting	Option B Composting	Option C AD & Composting	Option D AD & Composting	Option E Composting	Option F Composting
Cost Category	Covered Static Pile	CASP	AD-D & Covered Static Pile	AD-C & CASP	Covered Static Pile	CASP
Utilities	2,400	2,400	2,400	2,400	2,400	2,400
Telephone	6,000	6,000	6,000	6,000	6,000	6,000
Information Technology	18,000	18,000	18,000	18,000	18,000	18,000
Office Supplies	6,000	6,000	6,000	6,000	6,000	6,000
Facility/Landscaping	-	-	-	-	-	-
Janitorial	6,000	6,000	6,000	6,000	6,000	6,000
Operating Supplies	6,000	6,000	6,000	6,000	6,000	6,000
Personal Protection Equipment	6,000	6,000	6,000	6,000	6,000	6,000
<b>TOTAL</b>	<b>50,400</b>	<b>50,400</b>	<b>50,400</b>	<b>50,400</b>	<b>50,400</b>	<b>50,400</b>

### Equipment Operating Expenditures

						WWTP				UC DAVIS	
						OPTION A Composting	OPTION B Composting	Option C AD & Composting	Option D AD & Composting	Option E Composting	Option F Composting
Equipment	Hours per Day	Hours per Month <sup>1</sup>	\$/Hour <sup>2</sup>	Monthly Expense	Annual Expense	AD-D & Covered Static Pile	CASP	AD-D & Covered Static Pile	AD-C & CASP	Covered Static Pile	CASP
Trommel	8.0	176.0	26.00	\$ 4,576	\$ 54,912	\$ 54,912	\$ 54,912	\$ 54,912	\$ 54,912	\$ 54,912	\$ 54,912
Tub Grinder	8.0	176.0	40.00	\$ 7,040	\$ 84,480	\$ 84,480	\$ 84,480	\$ 84,480	\$ 84,480	\$ 84,480	\$ 84,480
Loader	8.0	176.0	50.00	\$ 8,800	\$105,600	\$ 105,600	\$ 105,600	\$ 105,600	\$ 105,600	\$ 105,600	\$ 105,600
Water Truck	8.0	176.0	26.00	\$ 4,576	\$ 54,912	\$ 54,912	\$ 54,912	\$ 54,912	\$ 54,912	\$ 54,912	\$ 54,912
CASP						\$ 25,800		\$ 25,800		\$ 25,800	
AD-D							\$ 75,000				
AD-C								\$ 75,000			
Gas Cleanup							\$ 50,000	\$ 150,000			
<b>Total OPEX</b>						<b>\$ 299,904</b>	<b>\$ 270,792</b>	<b>\$ 424,904</b>	<b>\$ 495,792</b>	<b>\$ 299,904</b>	<b>\$ 270,792</b>

Notes

1. Assumes 264 days per year.
2. Includes fuel and maintenance if applicable.

## Debt Service

	WWTP OPTION A COMPOSTING  COVERED STATIC PILE	WWTP OPTION B COMPOSTING  CASP	WWTP Option C AD & Composting AD-D & Covered Static Pile	WWTP Option D AD & Composting  AD-C & CASP
<b>1 Building / Facility</b>				
Loan Amount (\$)	\$ 332,000	\$ 311,000	\$ 332,000	\$ 1,561,000
Interest Rate (%)	5.00%	5.00%	5.00%	5.00%
Term (Years)	20	20	20	20
No. Payments	240	240	240	240
Monthly Payment	\$ 2,191	\$ 2,052	\$ 2,191	\$ 10,302
Interest Expense (\$/year)	\$ 16,375	\$ 15,339	\$ 16,375	\$ 76,991
Principal Payment (\$/year)	\$ 9,918	\$ 9,291	\$ 9,918	\$ 46,632
Total Payments (\$/year)	\$ 26,293	\$ 24,630	\$ 26,293	\$ 123,623
Replacement fund	\$ -	\$ -	\$ -	\$ -
<b>2 Processing Equipment</b>				
Loan Amount (\$)	\$ 450,000	\$ 6,550,000	\$ 21,050,000	\$ 28,876,000
Interest Rate (%)	5.00%	5.00%	5.00%	5.00%
Term (Years)	10	10	10	10
No. Payments	120	120	120	120
Monthly Payment	\$ 4,773	\$ 69,473	\$ 223,268	\$ 306,275
Interest Expense (\$/year)	\$ 21,692	\$ 315,738	\$ 1,014,698	\$ 1,391,945
Principal Payment (\$/year)	\$ 35,583	\$ 517,937	\$ 1,664,516	\$ 2,283,353
Total Payments (\$/year)	\$ 57,275	\$ 833,675	\$ 2,679,215	\$ 3,675,297
Replacement fund	\$ 45,000	\$ 655,000	\$ 2,105,000	\$ 2,887,600

## Debt Service

	WWTP OPTION A COMPOSTING  COVERED STATIC PILE	WWTP OPTION B COMPOSTING  CASP	WWTP Option C AD & Composting AD-D & Covered Static Pile	WWTP Option D AD & Composting  AD-C & CASP
<b>3 Rolling Stock</b>				
Loan Amount (\$)	\$ 250,000	\$ 200,000	\$ 250,000	\$ 200,000
Interest Rate (%)	5.00%	5.00%	5.00%	5.00%
Term (Years)	7	7	7	7
No. Payments	84	84	84	84
Monthly Payment	\$ 3,533	\$ 2,827	\$ 3,533	\$ 2,827
Interest Expense (\$/year)	\$ 11,805	\$ 9,444	\$ 11,805	\$ 9,444
Principal Payment (\$/year)	\$ 30,597	\$ 24,477	\$ 30,597	\$ 24,477
Total Payments (\$/year)	\$ 42,402	\$ 33,921	\$ 42,402	\$ 33,921
Replacement fund	\$ 35,714	\$ 28,571	\$ 35,714	\$ 28,571
<b>4 Other Equipment</b>				
Loan Amount (\$)	\$ 50,000	\$ 200,000	\$ 50,000	\$ 200,000
Interest Rate (%)	5.00%	5.00%	5.00%	5.00%
Term (Years)	7	7	7	7
No. Payments	84	84	84	84
Monthly Payment	\$ 707	\$ 2,827	\$ 707	\$ 2,827
Interest Expense (\$/year)	\$ 2,361	\$ 9,444	\$ 2,361	\$ 9,444
Principal Payment (\$/year)	\$ 6,119	\$ 24,477	\$ 6,119	\$ 24,477
Total Payments (\$/year)	\$ 8,480	\$ 33,921	\$ 8,480	\$ 33,921
Replacement fund	\$ 7,143	\$ 28,571	\$ 7,143	\$ 28,571
<b>5 TOTAL</b>				
Loan Amount (\$)	\$ 1,082,000	\$ 7,261,000	\$ 21,682,000	\$ 30,837,000
Monthly Payment	\$ 11,204	\$ 77,179	\$ 229,699	\$ 322,230
Interest Expense (\$/year)	\$ 52,233	\$ 349,965	\$ 1,045,239	\$ 1,487,824
Principal Payment (\$/year)	\$ 82,217	\$ 576,182	\$ 1,711,150	\$ 2,378,939
Total Payments (\$/year)	\$ 134,450	\$ 926,147	\$ 2,756,390	\$ 3,866,763
Replacement fund	\$ 87,857	\$ 712,143	\$ 2,147,857	\$ 2,944,743

## Capital Expenditures

WWTP											
OPTION A - COMPOSTING COVERED STATIC PILE				OPTION B - COMPOSTING CASP				Option C - AD & Composting AD-D & Covered Static Pile			
Building / Facility	Qty	Price	Total	Building / Facility	Qty	Price	Total	Building / Facility	Qty	Price	Total
Site Preparation	1.0	300,000	300,000	Site Preparation	1.0	300,000	300,000	Site Preparation	1.0	300,000	300,000
Storm Water	15.0	2,133	32,000	Storm Water	5.0	2,200	11,000	Storm Water	15.0	2,133	32,000
Unused			-	Unused			-	Unused			-
<b>Subtotal</b>			<b>332,000</b>	<b>Subtotal</b>			<b>311,000</b>	<b>Subtotal</b>			<b>332,000</b>
<b>Processing Equip</b>				<b>Processing Equip</b>				<b>Processing Equip</b>			
Trommel	1.0	200,000	200,000	Trommel	1.0	200,000	200,000	Trommel	1.0	200,000	200,000
Tub Grinder	1.0	250,000	250,000	Tub Grinder	1.0	250,000	250,000	Tub Grinder	1.0	250,000	250,000
Unused			-	CASP System	1.0	2,700,000	2,700,000	AD-D	1.0	8,000,000	8,000,000
Unused			-	CASP Construction	1.0	3,400,000	3,400,000	Construction	1.0	12,000,000	12,000,000
Unused			-	Unused			-	Gas Clean up (CoGen)	1.0	500,000	500,000
Unused			-				-	Pipeline and Connect to WWTP	1.0	100,000	100,000
Unused			-				-				
Unused			-				-				
Unused			-				-				
<b>Total Equip</b>			<b>450,000</b>	<b>Total Equip</b>			<b>6,550,000</b>	<b>Total Equip</b>			<b>21,050,000</b>
<b>Rolling Stock</b>				<b>Rolling Stock</b>				<b>Rolling Stock</b>			
Loader	1.0	200,000	200,000	Loader	1.0	200,000	200,000	Loader	1.0	200,000	200,000
Water Truck	1.0	50,000	50,000	Unused			-	Water Truck	1.0	50,000	50,000
Unused			-	Unused			-	Unused			-
Unused			-	Unused			-	Unused			-
<b>Total Rolling Stock</b>			<b>250,000</b>	<b>Total Rolling Stock</b>			<b>200,000</b>	<b>Total Rolling Stock</b>			<b>250,000</b>
<b>Other Equipment</b>				<b>Other Equipment</b>				<b>Other Equipment</b>			
Scale	1.0	50,000	50,000	Scale	1.0	50,000	50,000	Scale	1.0	50,000	50,000
Unused			-	Cover Winder Machine	1.0	150,000	150,000	Unused			-
<b>Total Other equip</b>			<b>50,000</b>	<b>Total Other equip</b>			<b>200,000</b>	<b>Total Other equip</b>			<b>50,000</b>
<b>TOTAL</b>			<b>1,082,000</b>	<b>TOTAL</b>			<b>7,261,000</b>	<b>TOTAL</b>			<b>21,682,000</b>

## Capital Expenditures

WWTP				UC DAVIS							
Option D - AD & Composting AD-C & CASP				OPTION E - COMPOSTING COVERED STATIC PILE				OPTION F - COMPOSTING CASP			
Building / Facility	Qty	Price	Total	Building / Facility	Qty	Price	Total	Building / Facility	Qty	Price	Total
Site Preparation	1.0	300,000	300,000	Site Preparation	1.0	300,000.00	300,000	Site Preparation	1.0	400,000.00	400,000
Storm Water	5.0	2,200	11,000	Storm Water	15.0	2,133	32,000	Storm Water	5.0	2,200	11,000
Receiving Building	1.0	1,250,000	1,250,000	Unused			-	Unused			-
<b>Subtotal</b>			<b>1,561,000</b>	<b>Subtotal</b>			<b>332,000</b>	<b>Subtotal</b>			<b>411,000</b>
<b>Processing Equip</b>				<b>Processing Equip</b>				<b>Processing Equip</b>			
Trommel	1.0	200,000	200,000	Trommel	1.0	200,000	200,000	Trommel	1.0	200,000	200,000
Tub Grinder	1.0	250,000	250,000	Tub Grinder	1.0	250,000	250,000	Tub Grinder	1.0	250,000	250,000
CASP System	1.0	2,700,000	2,700,000	Unused			-	CASP System	1.0	2,700,000	2,700,000
CASP Construction	1.0	3,400,000	3,400,000	Unused			-	CASP Construction	1.0	3,400,000	3,400,000
Gas Clean up (CNG)	1.0	6,226,000	6,226,000	Unused			-	Unused			-
Pipeline and Connect to											
WWTP	1.0	100,000	100,000	Unused			-	Unused			-
AD-C	1.0	8,000,000	8,000,000	Unused			-	Unused			-
Construction	1.0	8,000,000	8,000,000	Unused			-	Unused			-
<b>Total Equip</b>			<b>28,876,000</b>	<b>Total Equip</b>			<b>450,000</b>	<b>Total Equip</b>			<b>6,550,000</b>
<b>Rolling Stock</b>				<b>Rolling Stock</b>				<b>Rolling Stock</b>			
Loader	1.0	200,000	200,000	Loader	1.0	200,000	200,000	Loader	1.0	200,000	200,000
Unused			-	Water Truck	1.0	50,000	50,000	Unused			-
Unused			-	Unused			-	Unused			-
Unused			-	Unused			-	Unused			-
<b>Total Rolling Stock</b>			<b>200,000</b>	<b>Total Rolling Stock</b>			<b>250,000</b>	<b>Total Rolling Stock</b>			<b>200,000</b>
<b>Other Equipment</b>				<b>Other Equipment</b>				<b>Other Equipment</b>			
Scale	1.0	50,000	50,000	Scale	1.0	50,000	50,000	Scale	1.0	50,000	50,000
Cover Winder Machine	1.0	150,000	150,000	Unused			-	Cover Winder Machine	1.0	150,000	150,000
<b>Total Other equip</b>			<b>200,000</b>	<b>Total Other equip</b>			<b>50,000</b>	<b>Total Other equip</b>			<b>200,000</b>
<b>TOTAL</b>			<b>30,837,000</b>	<b>TOTAL</b>			<b>1,082,000</b>	<b>TOTAL</b>			<b>7,361,000</b>

# **APPENDIX G**

## **Project WARM Analysis**

---

# WASTE REDUCTION MODEL (WARM)

## TECHNICAL MEMORANDUM

---

October 2018

Prepared for: City of Davis

Prepared By: Clements Environmental, Corp.

### 1. INTRODUCTION

The Environmental Protection Agency Waste Reduction Model (WARM) calculates the greenhouse gas (GHG) emissions from six different waste management practices for over 50 material types. Waste management practices include source reduction, recycling, composting, anaerobic digestion, combustion, and landfilling. WARM provides the annual GHG emissions as metric tons of carbon dioxide equivalent (MTCO<sub>2</sub>E).

The City of Davis is assessing different disposal and processing options for its organic waste and is interested in understanding the GHG generation or reduction of each option. This technical memo evaluates three waste management scenarios:

1. All organic materials sent to landfill disposal;
2. All organic materials sent to composting;
3. All allowable organic materials sent to anaerobic digestion and the remainder sent to composting.

For the purposes of this report, the City of Davis (City) organic waste (12,672 tons per year) has been combined with the available organic waste (12,804 tons per year) from University of California, Davis (UCD). **Tables 4.5** and **4.6** in the *Organics Processing Facility Feasibility Analysis* (Report) show the breakdown of these organic feedstocks.

### 2. ASSUMPTIONS OF THE WARM MODEL

To determine the GHG emissions from these three scenarios, the following assumptions were made in accordance with the WARM calculation method:

- All organic material is combined into one category, which includes green material, food and commingled food/green material and other organics;
- Assigns a value of 20 miles for transportation distances, when factoring in the emissions generated from the transport of materials to a disposal or processing site;



- The composting method is traditional windrow with no specified air quality best management practices;
- Anaerobic digestion utilizes dry digestion technology.

For each waste management scenario, WARM accounts for sources of emissions (e.g., combustion of fossil fuels) and emissions sinks (e.g., forest carbon storage, avoid fuel consumption). When the results in WARM show a negative value for GHG emissions or energy, this indicates that managing that material using the selected management practice results in overall avoided GHG emissions or energy from a life-cycle perspective.

*Attachment 1* of this technical memo includes WARM's description of the emissions sources and sinks as they relate to the above scenarios.

### 3. WARM RESULTS

Three waste management scenarios were evaluated using WARM. The results of each scenario are summarized below in **Table 1**.

**Table 1.** Annual Metric Tons of Carbon Dioxide Equivalent (MTCO<sub>2</sub>E) Generated or Reduced

WASTE MANAGEMENT SCENARIO	ANNUAL GHG EMISSIONS (MTCO <sub>2</sub> E)		
	City	UCD	Combined
Feedstock Generator			
Landfill Disposal	2,772.63	2,801.51	5,574.14
Composting	-2,049.80	-2,071.15	-4,120.95
AD with Composting	-	-	-3,946.54

#### Landfill Disposal Scenario

If all organic waste from both the City and UCD were sent to landfill for disposal, then roughly 5,600 MTCO<sub>2</sub>E of GHG emissions would be generated each year.

#### Composting Scenario

These combined organic wastes would yield an annual reduction of about 4,000 MTCO<sub>2</sub>E when sent to composting. When compared to landfill disposal, this is an overall GHG reduction of about 9,700 MTCO<sub>2</sub>E.

The reduction in GHG emissions means this waste management practice results in overall avoided GHG emissions or energy from a life-cycle perspective. For composting, this includes carbon storage potential in compost application.

### AD with Composting Scenario

For this scenario, only a portion of the organic wastes would be sent to the AD system. The residual digestate would then be mixed with any organic waste that was not digested, e.g. animal bedding, and sent to composting.

Consistent with the tonnages outlined in the Report, 14,124 TPY would be sent to anaerobic digestion, and another 18,414 TPY would be sent to composting. This waste management practice would result in a GHG reduction of about 4,000 MTCO<sub>2</sub>E. The WARM considers carbon storage, avoided fertilizer offsets, and net electricity offsets.

## **4. CONCLUSION**

Based on the WARM assumptions, both composting and AD with composting generate similar GHG reductions and landfill disposal generates the most significant GHG emissions. It is important to note that the WARM model assumed windrow composting and dry anaerobic digestion which WARM identifies as the most commonly used technologies. However, in California and beyond there are more advanced systems such as aerated composting and high solids anaerobic digestion. Aerated composting systems have been shown to reduce emissions by 50 to 95% when compared to traditional windrow composting, but also require more energy than non-aerated systems. Similarly, high solids anaerobic digestion has been shown to produce more biogas than dry AD systems, which results in more renewable heat, electricity, or fuel generation.

While the WARM may not be up-to-date on current technologies, the results of this tool are meant to provide information on the GHG impacts from material management decisions.

# **APPENDIX H**

## **Composting Operations Energy Requirements Tech. Memo.**

---

# COMPOSTING OPERATIONS ENERGY REQUIREMENTS TECHNICAL MEMORANDUM

---

November 2018

Prepared For: City of Davis  
Prepared By: Clements Environmental, Corp.

## 1.0 INTRODUCTION

This technical memorandum is to support the Anaerobic Digestion (AD) Energy Balance performed by Robert Williams and Joerg Blischke (subconsultants to Diversion Strategies). Two AD options were evaluated based on the Clements Team's *Organics Processing Facility Feasibility Analysis* (Report).

- Option C: High Solids AD – Discontinuous and windrow composting producing electricity and compost
- Option D: High Solids AD – Continuous with covered aerated static pile composting producing renewable compressed natural gas (R-CNG) and compost

Both options assume the composting portion will receive about 70 tons per day, as show in **Table 4.7** in the Report.

## 2.0 COMPOSTING OPERATIONS EQUIPMENT

To be consistent with the Report, the less advanced equipment (e.g. diesel) were assigned to the windrow composting operations and the more advance equipment (e.g. electric) were assigned to the aerated static pile composting operations. To date, there are no all-electric front end loaders, so both options utilize diesel loaders.

### Windrow Composting Equipment

- Diesel Grinder
- Diesel Loader
- Diesel Trommel Screen

### Covered Aerated Static Pile Composting Equipment

- Electric Grinder
- Diesel Loader
- Electric Trommel Screen
- Aeration Blowers

### 3.0 WINDROW COMPOSTING ENERGY REQUIREMENTS

**Table 1. Windrow Composting Energy Requirements**

Equipment	Engine Performance	Fuel Consumption	Process Rate	Hours per Day	Annual <sup>1</sup> Consumption
Diesel Grinder	1,050 hp / 783 kW	53.4 gal/hour	50 tons per hour	1.5	21,146 gal.
Diesel Loader	164 hp / 122 kW	9.1 gal/hour	-	4	9,610 gal.
Diesel Trommel Screen	174 hp / 130 kW	9.45 gal/hour	50 tons per hour	1.5	3,742 gal.
<b>Annual Diesel Consumption</b>					<b>34,498 gal.</b>

<sup>1</sup>Year based on 264 operating days when materials are received.

#### *Energy Requirements & Greenhouse Gas Impact*

Assuming all engines comply with the U.S. EPA Tier 4 emissions standards for Heavy Equipment, **Table 2.** Displays estimated exhaust emissions from this scenario:

**Table 2. Windrow Composting Estimated Diesel Emissions**

Equipment	Engine Max. Power (kW)	Annual Operating Hours	Annual Power Consumption (kW-hr)	Annual Exhaust Emissions (pounds)			
				PM	NO <sub>x</sub>	VOC	CO
Grinder	783	396	310,068	14	273	130	3,418
Loader	122	1,056	128,832	11	994	54	994
Trommel Screen	130	396	51,480	2	45	22	397
<b>Total Emissions</b>				<b>27</b>	<b>1,313</b>	<b>205</b>	<b>4,809</b>

## 4.0 COVERED AERATED STATIC PILE ENERGY REQUIREMENTS

**Table 4. Aerated Composting Energy Requirements**

Equipment	Engine Performance	Fuel Consumption	Process Rate	Hours per Day	Annual <sup>1</sup> Consumption
Electric Grinder	600 hp / 447.42 kW	-	50 tons per hour	1.5	177,178 kWh.
Diesel Loader	164 hp / 122 kW	9.1 gal/hour	-	4	9,610 gal/yr.
Electric Trommel Screen	111 hp / 83 kW	-	42.50 tons per hour	1.5	32,868 kWh
Aeration Blowers	1.5 hp / 1.12 kW per pile	-		24	7,096 kWh
<b>Annual Diesel Consumption</b>					<b>9,610 gal.</b>
<b>Annual Electricity Consumption</b>					<b>217,142 kWh</b>

<sup>1</sup>Year based on 264 operating days when materials are received.

## 5.0 SUMMARY

The table below summarizes the energy requirements determined for both windrow and aerated composting. There may be other energy input requirements not listed here, such as additional feedstock preprocessing equipment (e.g. depackager) or composting process equipment (e.g. electric compost cover winding machine).

**Table 5. Composting Operations Energy Requirements**

	Units	Windrow Composting	Aerated Composting
Diesel	gallons/yr.	34,498	9,609
Electricity Total	kWh/yr.	-	217,142

## 6.0 REFERENCES

### Windrow Composting References:

- Diesel Grinder = Morback 1300B Tub Grinder
- Diesel Loader = CAT 930M Front End Loader
- Diesel Trommel Screen = McCloskey 628RE
- Fuel Efficiency = Diesel Service & Supply
- 22 working days per month
- Diesel Exhaust Emissions = EPA Tier 4 Exhaust Emission Standards (TABLE 1 OF §1039.101)

**TABLE 1 OF §1039.101—TIER 4 EXHAUST EMISSION STANDARDS AFTER THE 2014 MODEL YEAR, G/KW-HR<sup>1</sup>**

Maximum engine power	Application	PM	NO <sub>x</sub>	NMHC	NO <sub>x</sub> + NMHC	CO
kW <19	All	<sup>2</sup> 0.40			7.5	<sup>3</sup> 6.6
19 ≤kW <56	All	0.03			4.7	<sup>4</sup> 5.0
56 ≤kW <130	All	0.02	0.40	0.19		5.0
130 ≤kW ≤560	All	0.02	0.40	0.19		3.5
	Generator sets	0.03	0.67	0.19		3.5
kW >560	All except generator sets	0.04	3.5	0.19		3.5

<sup>1</sup>Note that some of these standards also apply for 2014 and earlier model years. This table presents the full set of emission standards that apply after all the transition and phase-in provisions of §1039.102 expire.

<sup>2</sup>See paragraph (c) of this section for provisions related to an optional PM standard for certain engines below 8 kW.

<sup>3</sup>The CO standard is 8.0 g/kW-hr for engines below 8 kW.

<sup>4</sup>The CO standard is 5.5 g/kW-hr for engines below 37 kW.

### Covered Aerated Static Pile Composting References:

- Electric Grinder = Vermeer HG6000E Horizontal Grinder
- Diesel Loader = CAT 930M Front End Loader
- Electric Trommel Screen = Terex TTS 520E – Fully Electric
- Fuel Efficiency = Diesel Service & Supply
- 22 working days per month
- Diesel Exhaust Emissions = EPA Tier 4 Exhaust Emission Standards
- Aeration from SJVAPCD May 2013 “Greenwaste Compost Site Emissions Reductions from Solar-powered Aeration and biofilter layer”

# **APPENDIX I**

## **Anaerobic Digestion Energy Balance Tech. Memo.**



---

# Anaerobic Digestion Energy Balance

## Technical Memorandum

---

November 2018

Prepared for: Clements Environmental Corp.

Prepared By: Robert Williams and Joerg Blischke (Subconsultants to Diversion Strategies)

**SUBJECT:** City of Davis Organics Processing Facility Feasibility Analysis;  
In-depth Assessment: Determine anaerobic digestion (AD) system energy requirements and energy production for both high-solids discontinuous (AD-D and continuous (AD-C) AD systems, with electricity and RNG production, respectively

---

This technical memorandum (TM) addresses questions related to energy inputs required to operate AD systems discussed in the Organics Processing Facility Feasibility Analysis (Report) and, based on those inputs, their net energy production. The following three subtopics are discussed in this TM:

1. Review literature, other published materials, and in-house information on AD system energy requirements and production.
2. Based on review, determine AD system energy input requirements for options "C" & "D".
3. Estimate net energy production (for options "C" & "D") using energy input requirements determined above and energy outputs (heat, power, and RNG) listed in the Draft Feasibility Report.

### Literature Review

Digester systems typically require heat to maintain appropriate temperature, electricity to operate pumps, conveyors, and feedstock mixing, and vehicle/diesel fuel for feedstock loading and handling. Biogas upgrading requires electricity to pump and move gas through the separation process and to compress for final use (i.e., pipeline injection or vehicle fuel). Published and in-house information on energy inputs for high solids anaerobic digester (HS-AD) and biogas upgrading was reviewed including information from operating facilities in Germany and North America, and peer reviewed journals.

Electricity demand is 44 - 47 kWh/ton and 18 - 31 kWh/ton for continuous and batch loaded (discontinuous) systems, respectively. The continuous systems generally require more feedstock processing (chopping, grinding, etc.) and more energy to convey the material through the system. Thermal energy requirements are about 0.28 MMBtu/ton and 0.09 - 0.22 MMBtu/ton for continuous and batch loaded systems, respectively. Most continuous HS-AD operate at the thermophilic temperature (131-140 °F) range while batch systems operate at either mesophilic (93-98 °F) or thermophilic temperatures. Diesel fuel input ranged from 0.24 to 0.4 gallons per ton with batch systems tending toward the higher

end of the range because feedstock and digestate are typically loaded and removed by diesel powered wheeled loaders.

Biogas upgrading electrical energy ranged from about 11 to 19 kWh/MMBtu of biomethane. The low end of the range applies to large capacity systems or do not include compression energy to vehicle fuel pressures (3000 – 3600 psi).

Representative values for use in subtopics 2 and 3 are given in Table 1 (see Appendix for comprehensive tables displaying data from the review). The values for Digester energy input are based on the report from the Technical University Braunschweig (et al.) which monitored several operating HS-AD systems in Germany<sup>1</sup>. The biogas upgrade value is from the California Air Resources Board Low Carbon Fuel Standard (LCFS) pathway for upgraded biomethane for vehicle fuel<sup>2</sup>.

**Table 1. Energy Inputs for High Solids AD and Gas Upgrading**

Energy Type	Units	AD-Continuous	AD - Discontinuous	Upgrading to Renewable Natural Gas (RNG)	Source
Electricity	kWh/ton	44	21	-	1
Electricity	kWh/ MMBtu (of gas)	-	-	19	2
Heat	MMBtu/ ton	0.28	0.09	-	1
Diesel	Gallons/ton	0.24	0.36	-	1

Source:

1 Technical University Braunschweig, Bauhaus-University Weimar, Fraunhofer Umsicht (2012). Steigerung der Energieeffizienz bei der Verwertung biogener Reststoffe: Endbericht zu Förderprojekt 03KB022 (German) [Increase in energy efficiency in the recycling of biogenic residues: final report on funded project with grant no. 03KB022].

<https://doi.org/10.2314/GBV:773389504>

2. Ahuja, K., Helmowski, B., & Ingram, W. (2014). LCFS Pathway for the Production of Biomethane from High Solids Anaerobic Digestion (HSAD) of Organic (Food and Green) Wastes. *Staff Report. California Air Resources Board.*

<sup>1</sup> Technical University Braunschweig, Bauhaus-University Weimar, Fraunhofer Umsicht (2012). Steigerung der Energieeffizienz bei der Verwertung biogener Reststoffe: Endbericht zu Förderprojekt 03KB022 (German) [Increase in energy efficiency in the recycling of biogenic residues: final report on funded project with grant no. 03KB022]. <https://doi.org/10.2314/GBV:773389504>

<sup>2</sup> Ahuja, K., Helmowski, B., & Ingram, W. (2014). LCFS Pathway for the Production of Biomethane from High Solids Anaerobic Digestion (HSAD) of Organic (Food and Green) Wastes. *Staff Report. California Air Resources Board*

## Energy requirements for options “C” & “D”.

### AD System Assumptions

This technical memo utilizes the assumptions provided in the Report, which include the following:

- 53.5 tons per day throughput capacity
- 22 working days per month; 264 days per year receiving material (14,124 tons per year)
- Feedstock composition: 98% greenwaste and 2% foodwaste

Option C from the Report is: “AD Discontinuous (Batch) with Windrow Composting (for the digestate and non-digestible feedstocks) with electricity produced from the biogas” (Figure 1). The Combined heat and power (CHP) system can typically satisfy the heat requirement. We estimate 294,641 kWh/yr and 5,077 gallons/yr of electricity and diesel, respectively, are needed to operate the Option C digester based on 14,124 tons per year of feedstock (including 2% food waste) (Figure 1 and Table 2). Electricity for operating the system is either purchased from the grid or supplied from the CHP system.

**Figure 1. Schematic of AD – Discontinuous (Batch) with Electricity Production (Option C)**

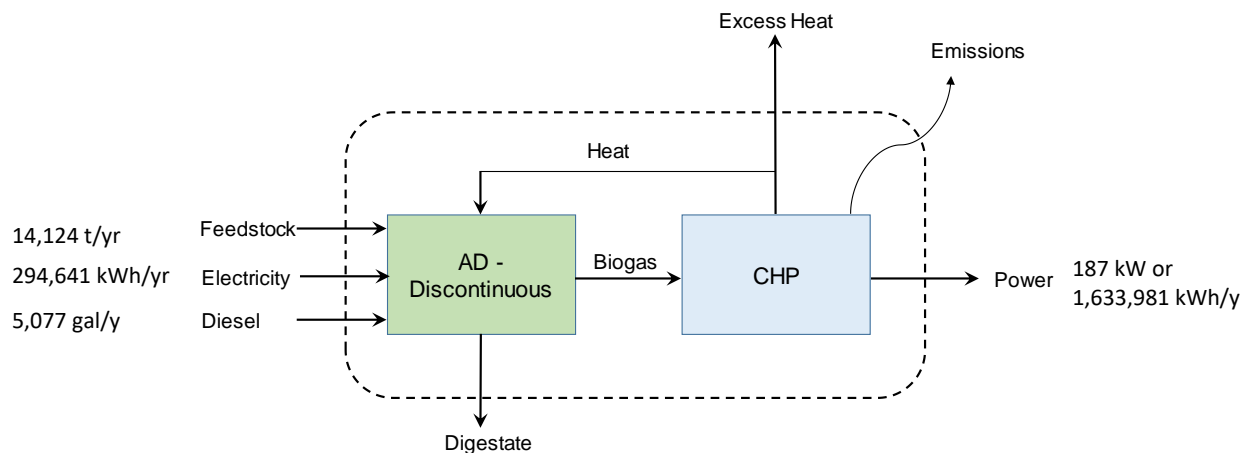

Option D from the Report is: “AD Continuous (Plug-flow) with Aerated Composting (for the digestate and non-digestible feedstocks) with renewable compressed natural gas (R-CNG) produced from the biogas” (Figure 2). This system requires heat from burning natural gas or a portion of the biogas because we assume no usable waste heat from other processes. Electricity is required for both the AD and the gas upgrading processes. We estimate 614,902 kWh/yr, 3,385 gallons/yr, and 4,021 MMBtu/yr of electricity, diesel, and heat, respectively, are needed to operate the Option 4 digester based on 14,124 tons per year of feedstock (including 2% food waste) (Figure 2 and Table 2).

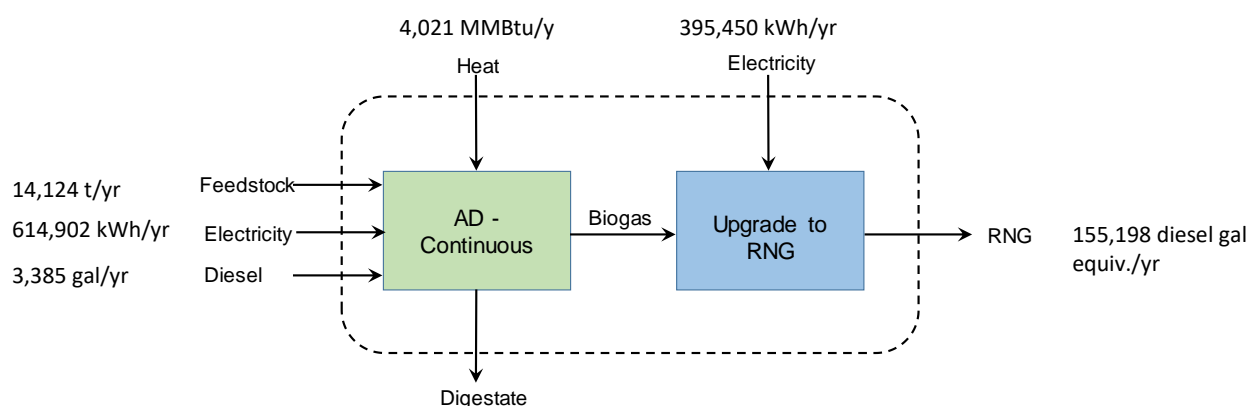
**Figure 2. Schematic of AD – Continuous (Plug-flow) with RNG Production (Option D)****Net Energy Production**

Option 3 produces 1,633,981 kWh/yr and 1,339,341 kWh/yr of gross and net electricity, respectively and requires 5,077 gallons per year of diesel fuel (Table 2).

Option 4 produces 155,198 diesel gallon equivalents per year of R-CNG. It requires 1,010,352 kWh/yr, 4,021 MMBtu/yr, and 3,385 gallons/yr of electricity, heat, and diesel, respectively (Table 2).

**Table 2. Input, Output, and Net Energy for the High Solids AD Systems in Options C and D**

	Units	Option C AD-D w/ power production	Option D AD-C w/ CNG production
Throughput (w/2% food scraps)	Short tons/yr	14,124	14,124
Energy Input			
Diesel	gallons/yr	5,077	3,385
Heat	MMBtu/yr	1,311	4,021
Electricity (digester)	kWh/yr	294,641	614,902
Electricity (gas upgrading)	kWh/yr	-	395,450
<b>Electricity Total</b>	<b>kWh/yr</b>	<b>294,641</b>	<b>1,010,352</b>
Output			
Biogas	(MMscf/yr)	27.7	39.2
Methane content	[%]	55%	55.1%
Biogas energy	(MMBtu/yr)	14,672	20,823
RNG Production (assumes 96% recovery)	dge/yr	-	155,198
Electricity Production	kW	187	-
Electricity Production	kWh/yr	1,633,981	-
Heat Production	MMBtu/yr	6,749	-
Net Energy ( - is net input, + is net output)			
Diesel	gallons/yr	-5,077	-3,385
Heat	MMBtu/yr	5,438	-4,021
Electricity Total	kWh/yr	1,339,341	-1,010,352
R-CNG	dge/yr	-	155,198

The biogas and energy production estimates above are based on feedstock with 2% food waste and 98% green waste (by weight). Table 3 and Figures 3 - 5 below display estimated biogas and net energy outputs for food waste fractions of 2, 5, and 10% of feedstock. The total annual feedstock amount remained the same at 14,124 tons. Biogas production increases ~1% for each 1% increase in food waste fraction. The net electricity production for Option C (Figure 4) increases at a slightly higher rate than food waste increase because the energy input for the process remains the same.

**Table 3. Biogas and Energy Production and Input Versus Food Waste Fraction**

Food Waste Fraction	Option C – Discontinuous		Option D - Continuous		
	Biogas (MMBtu/y)	Net Electricity Product (MWh/y)	Biogas (MMBtu/y)	R-CNG (dge)*	Electricity Input (MWh/y)
2%	14,669	1.34	20,819	155,166	1.01
5%	15,100	1.39	21,431	159,729	1.02
10%	15,820	1.47	22,452	167,336	1.04

\*Assumes 95% of methane is recovered as R-CNG. (dge) = diesel gallon equivalent

**Figure 3. Biogas Production vs. Food Waste Fraction for Options C and D.**

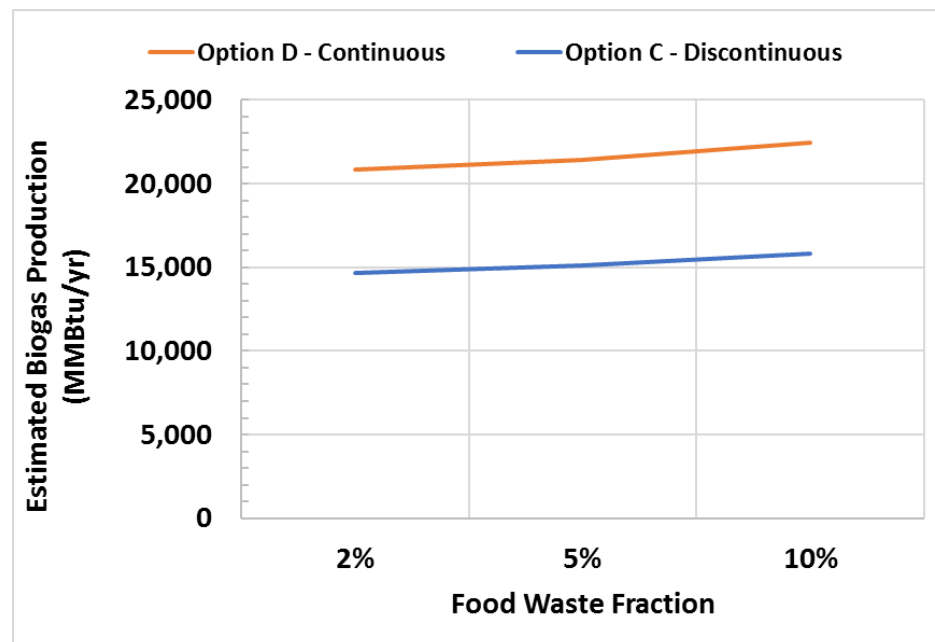

Figure 4. Net Electricity Production vs. Food Waste fraction for Option C.

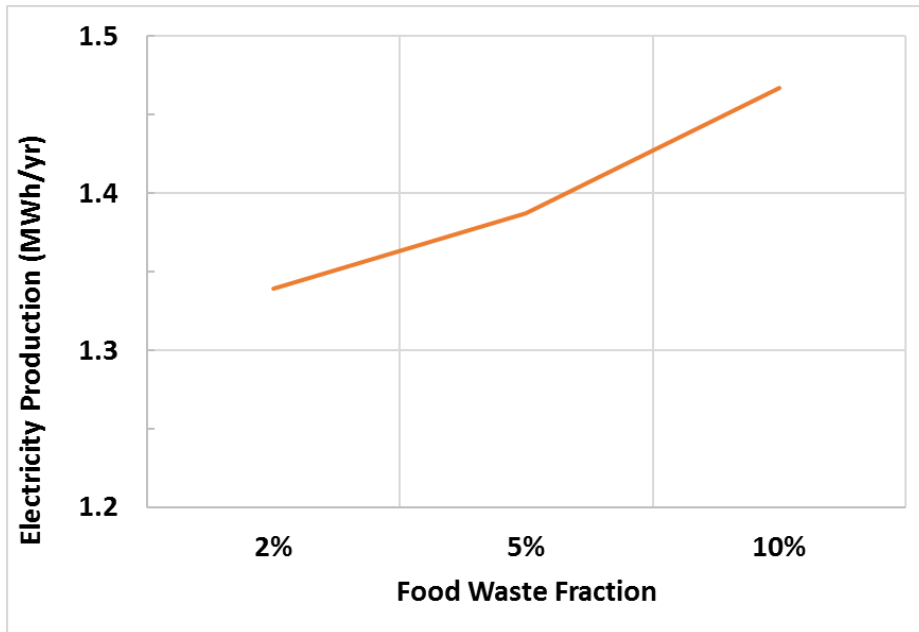
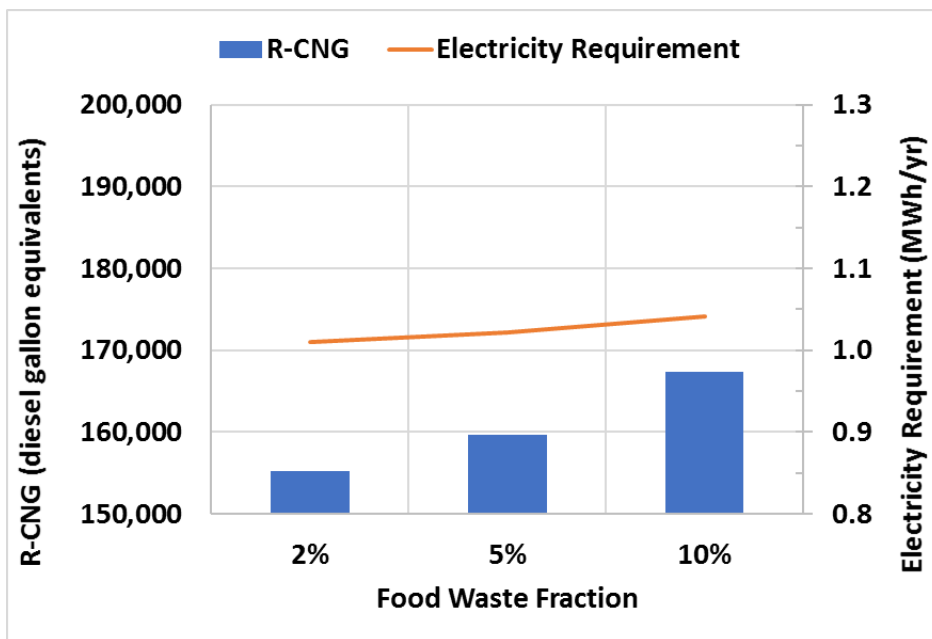

Figure 5. R-CNG Output and Electricity Input vs. Food Waste Fraction for Option 4.



## Appendix

Literature review tables and references.

**Table 4: Electric and Thermal Energy Inputs for HSAD from Literature.**

	Continuous (Plug-flow)			Discontinuous (Batch)		
	kWh/ short ton	Comment	Source	kWh/ short ton	Comment	Source
Electric	44		1	21		1
	47	Valorga process	2	18	HSAD LCFS Document	3
				31	Blueline	4
				55	Blueline w/ ammonia scrubbing	4
Thermal load	MMBtu/ short ton	Comment	Source	MMBtu/ short ton	Comment	Source
	0.28		1	0.09		1
	0.29		5	0.04	Revised calc. in HSAD LCFS Document	3
				0.22	Blueline GHG Analysis	4
Diesel	Gallons/ short ton	Comment	Source	Gallons/ short ton	Comment	Source
	0.24		1	0.36		1
				0.4	Blueline GHG Analysis	4

Sources:

1. Technical University Braunschweig, Bauhaus-University Weimar, Fraunhofer Umsicht (2012). Steigerung der Energieeffizienz bei der Verwertung biogener Reststoffe: Endbericht zu Förderprojekt 03KB022 (German) [Increase in energy efficiency in the recycling of biogenic residues: final report on funded project with grant no. 03KB022]. <https://doi.org/10.2314/GBV:773389504>.
2. Bolzonella, D., Pavan, P., Mace, S., & Cecchi, F. (2006). Dry anaerobic digestion of differently sorted organic municipal solid waste: A full-scale experience. *Water Science and Technology*, 53(8), 23–32. <https://doi.org/10.2166/wst.2006.232>.
3. Ahuja, K., Helmowski, B., & Ingram, W. (2014). LCFS Pathway for the Production of Biomethane from High Solids Anaerobic Digestion (HSAD) of Organic (Food and Green) Wastes. *Staff Report. California Air Resources Board*.
4. Moore, R., & Readle, G. (2015). Blue Line Biogenic CNG Facility. *Contractor Report to the California Energy Commission. Alternative and Renewable Fuel and Vehicle Technology Program., CEC-ARV-12*.
5. Ardolino, F., Parrillo, F., & Arena, U. (2018). Biowaste-to-biomethane or biowaste-to-energy? An LCA study on anaerobic digestion of organic waste. *Journal of Cleaner Production*, 174, 462–476. <https://doi.org/10.1016/j.jclepro.2017.10.320>.

**Table 5. Biogas Upgrading Electrical Energy Requirements**

kWh /scf raw biogas	kWh/ scf biomethane	kWh/ MMBtu biomethane	Source	Comment
0.0082	0.015	14.9	1	high efficiency 3-stage membrane separation
0.0071	0.013	12.9	2	w/ Grid injection
0.0091	0.016	16.5	2	w/ onsite vehicle fueling
0.0062	0.011	11.3	3	"large scale"
0.0078	0.014	14.2	3	"small scale"
0.0059	0.011	10.8	4	"large scale"
0.0085	0.015	15.4	4	"small scale"
0.0123	0.019	19.0	5	HSAD LCFS Document
0.0079	0.014	14.4	6	Upgrading w/ compression (GREET)
0.0483	0.088	87.8	7	Blueline: ~ 6 times average. Blueline admits "significantly more energy intensive than CARB pathway"

## Sources:

1. Ardolino, F., Parrillo, F., & Arena, U. (2018). Biowaste-to-biomethane or biowaste-to-energy? An LCA study on anaerobic digestion of organic waste. *Journal of Cleaner Production*, 174, 462–476. <https://doi.org/10.1016/j.jclepro.2017.10.320>.
2. Rotunno, P., Lanzini, A., & Leone, P. (2017). Energy and economic analysis of a water scrubbing based biogas upgrading process for biomethane injection into the gas grid or use as transportation fuel. *Renewable Energy*, 102, 417–432. <https://doi.org/10.1016/j.renene.2016.10.062>.
3. Muñoz, R., Meier, L., Diaz, I., & Jeison, D. (2015). A review on the state-of-the-art of physical/chemical and biological technologies for biogas upgrading. *Reviews in Environmental Science and Biotechnology*, 14(4), 727–759. <https://doi.org/10.1007/s11157-015-9379-1>.
4. Bauer, F., Persson, T., Hulteberg, C., & Tamm, D. (2013). Biogas upgrading – technology overview, comparison and perspectives for the future. *Biofuels Bioprod Biorefin*, 7, 499–511.
5. Ahuja, K., Helmowski, B., & Ingram, W. (2014). LCFS Pathway for the Production of Biomethane from High Solids Anaerobic Digestion (HSAD) of Organic (Food and Green) Wastes. *Staff Report. California Air Resources Board*.
6. Lee, U., Han, J., Demirtas, M. E., & Wang, M. (2016). Lifecycle Analysis of Renewable Natural Gas and Hydrocarbon Fuels from Wastewater Treatment Plants' Sludge. *Argonne National Lab; ANL/ESD-16/19*.
7. Moore, R., & Readle, G. (2015). Blue Line Biogenic CNG Facility. *Contractor Report to the California Energy Commission. Alternative and Renewable Fuel and Vehicle Technology Program., CEC-ARV-12*.